

Since 1985

TOPRAKÇILAR

MAKİNA SANAYİ VE TİC. LTD. ŞTİ

BULGUR ÜRETİM MAKİNALARI

BULGUR PRODUCTION MACHINES

ÖN TEMİZLEME SEPERATÖRÜ
PRE-CLEANING SEPERATOR



www.toprakcilarmakina.com

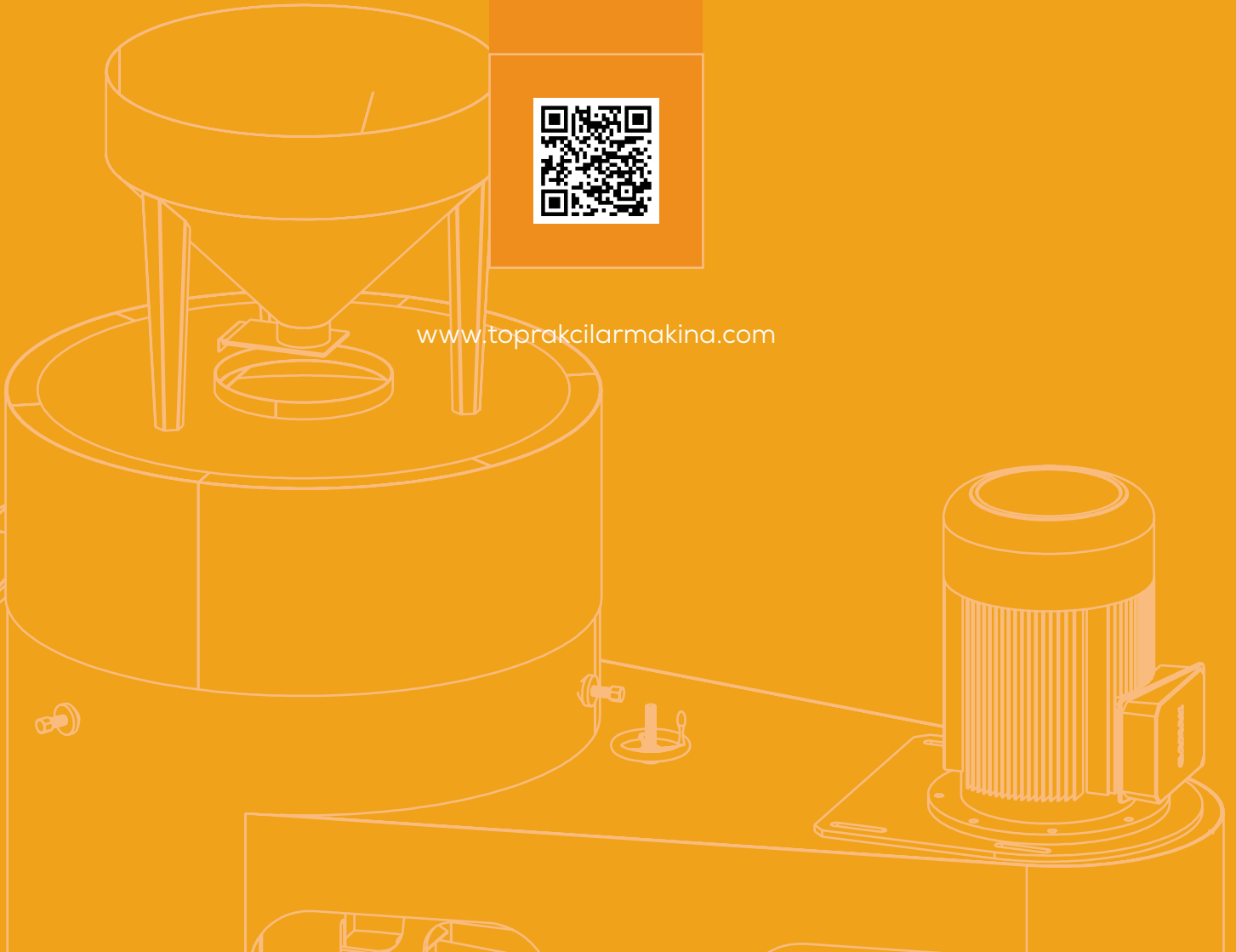

HAKKIMIZDA

ABOUT US



TR

Toprakçılar Makina, 1985'ten beri bulgur, yem ve pelet sektöründe öncü bir kuruluş olup, yenilikçiliği mühendislik uzmanlığıyla harmanlamaktadır. 10.000 m² açık ve 4.000 m² kapalı alana yayılmış olan firmamız, titiz üretime ve sarsılmaz kalite standartlarına kendini adanmıştır. Toprakçılar Makina olarak, makinelerden daha fazlasını sunuyoruz; ürettiğimiz her makineyle bulgur üretiminin geleceğini şekillendirme ve sektöre kalıcı katkılarda bulunma taahhüdünde bulunuyoruz. Mirasımız yalnızca ürünlerimizle değil, aynı zamanda sağladığımız operasyonel verimlilikle de tanımlanmaktadır. Toprakçılar ailesinin bir parçası olarak, yenilikçiliğe ve liderliğe olan bağlılığımız, tekliflerimizin her noktasında açıkça görülmektedir.

EN

Toprakçılar Makina has been a leading organization in the bulgur, feed, and pellet sector since 1985, blending innovation with engineering expertise. Spanning 10,000 m² of outdoor and 4,000 m² of indoor facilities, our company is dedicated to meticulous production and unwavering quality standards. At Toprakçılar Makina, we offer more than machinery; we provide a commitment to shaping the future of bulgur production and making enduring contributions to the industry with each machine we produce. Our legacy is defined not only by our products but also by the operational efficiency we deliver. As part of the Toprakçılar family, our dedication to innovation and leadership is evident in every aspect of our offerings.



ÖN TEMİZLEME SEPERATÖRÜ

PRE-CLEANING SEPARATOR

TEKNİK ÇİZİM VE ÖZELLİKLER

TECHNICAL DRAWING AND FEATURES

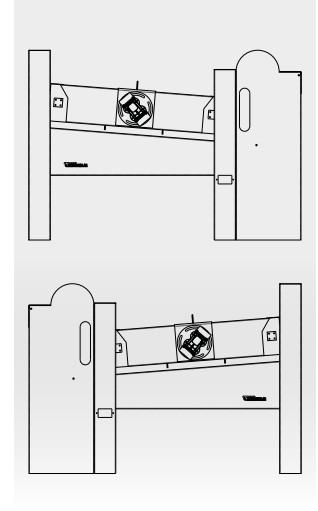
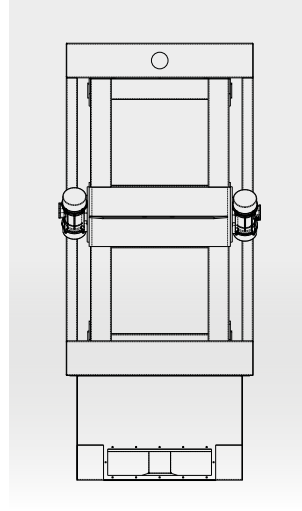
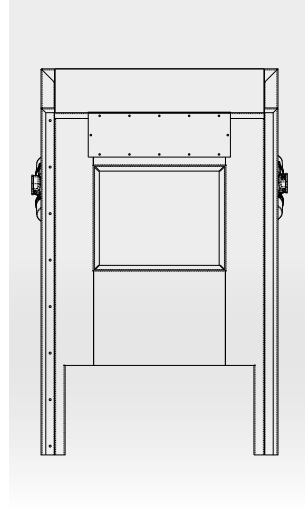
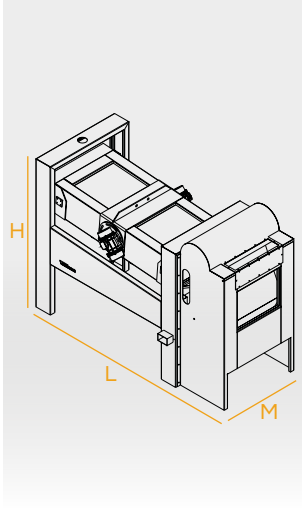

MODEL MODEL	MOTOR GÜCÜ MOTOR POWER	HAVA KANALI AIR DUCT	ELEME ALANI SCREENING AREA	KAPASİTE CAPACITY	M-L-H
TM-OTS10	0,55kW	Yok None	Tek kat Single layer	1000Kg/h	M: 1250 ^{mm} L: 2400 ^{mm} H: 1750 ^{mm}
TM-OTS25H	2x0,95kW	Var There is	Çift kat Double layer	2500Kg/h	M: 1350 ^{mm} L: 3150 ^{mm} H: 2200 ^{mm}
TM-OTS50H	2x1,1kW	Var There is	Çift kat Double layer	5000Kg/h	M: 1350 ^{mm} L: 3600 ^{mm} H: 2200 ^{mm}



TR

Ön temizleme seperatörü, tarımsal ürünlerin işleme sürecinde önemli bir role sahiptir. Hasat sonrası ürünlerin ilk aşamada yabancı maddelerden arındırılmasını sağlar. Tohumlar, saman, taşlar ve diğer istenmeyen parçacıkların ayrılmasını kolaylaştırır, böylece ürünlerin kalitesi artar ve sonraki işlemler için hazır hale gelir. Ön temizleme seperatörleri titreşim veya hava akımı kullanarak çalışır; bu yöntemler ürünün homojen bir şekilde temizlenmesini sağlar.

EN

The pre-cleaning separator plays a crucial role in the processing of agricultural products. It ensures the initial removal of foreign matter from harvested products. It facilitates the separation of seeds, straw, stones, and other unwanted particles, thereby improving the quality of the products and preparing them for subsequent processing stages. Pre-cleaning separators operate using vibration or air flow, methods that ensure homogeneous cleaning of the product.

*Değirmencilik sektöründe
profesyonel çözümler*

*Professional solutions in
milling industry*



INSTAGRAM



YOUTUBE



WEBSITE



LINKEDIN

www.toprakcilarmakina.com

ORGANİZE SANAYİ BÖLGESİ 13. SOKAK NO:3
MERKEZ / KARAMAN / TÜRKİYE