

Since 1985

# TOPRAKÇILAR

MAKİNA SANAYİ VE TİC. LTD. ŞTİ

YEM PELET ÜRETİM MAKİNALARI  
FEED PELLETT PRODUCTION MACHINES

**VİBRO PELET ELEK**  
**VIBRO PELLETT SIEVE**



[www.toprakcilmakina.com](http://www.toprakcilmakina.com)

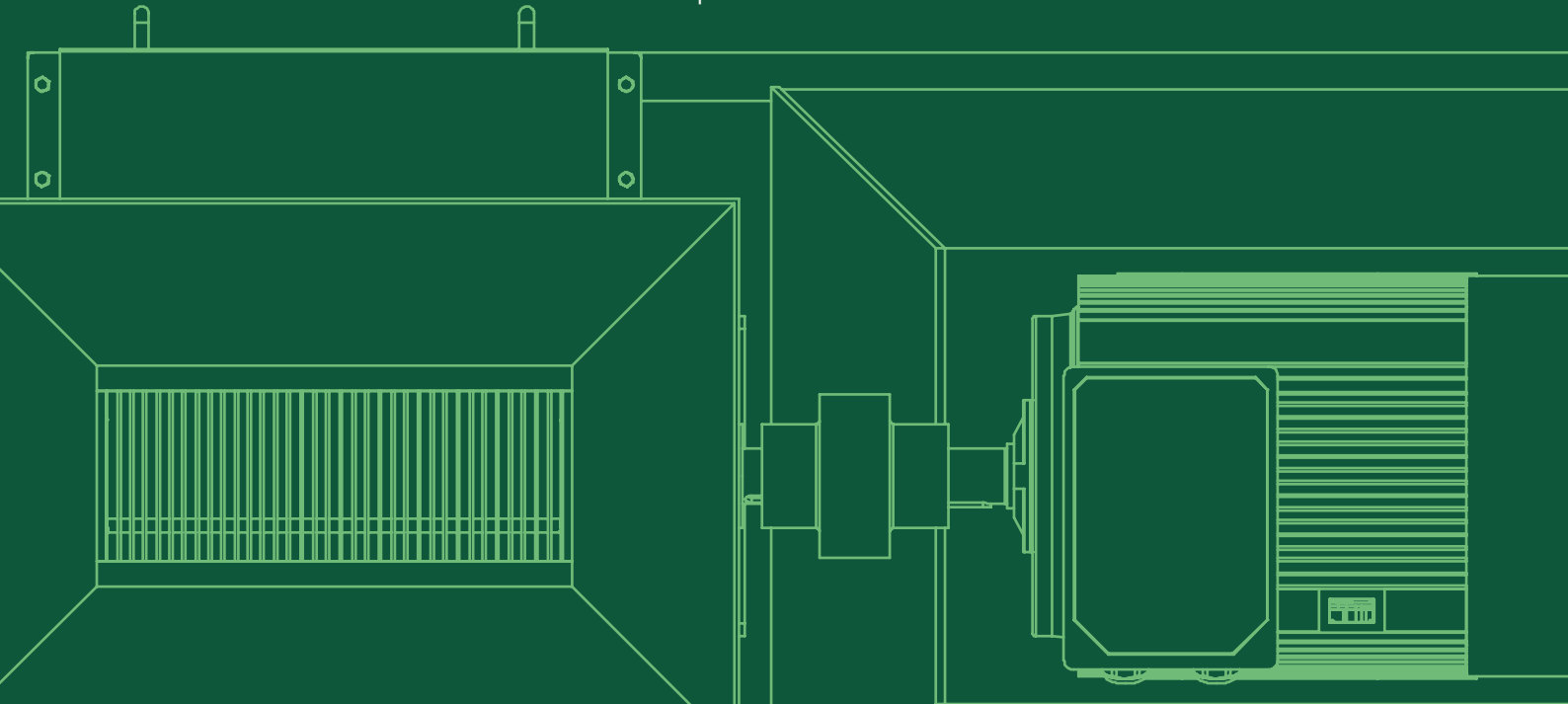

# HAKKIMIZDA

## ABOUT US



### TR

Toprakçılar Makina, 1985'ten beri bulgur, yem ve pelet sektöründe öncü bir kuruluş olup, yenilikçiliği mühendislik uzmanlığıyla harmanlamaktadır. 10.000 m<sup>2</sup> açık ve 4.000 m<sup>2</sup> kapalı alana yayılmış olan firmamız, titiz üretime ve sarsılmaz kalite standartlarına kendini adanmıştır. Toprakçılar Makina olarak, makinelerden daha fazlasını sunuyoruz; ürettiğimiz her makineyle bulgur üretiminin geleceğini şekillendirme ve sektöre kalıcı katkılarda bulunma taahhüdünde bulunuyoruz. Mirasımız yalnızca ürünlerimizle değil, aynı zamanda sağladığımız operasyonel verimlilikle de tanımlanmaktadır. Toprakçılar ailesinin bir parçası olarak, yenilikçiliğe ve liderliğe olan bağlılığımız, tekliflerimizin her noktasında açıkça görülmektedir.

### EN

Toprakçılar Makina has been a leading organization in the bulgur, feed, and pellet sector since 1985, blending innovation with engineering expertise. Spanning 10,000 m<sup>2</sup> of outdoor and 4,000 m<sup>2</sup> of indoor facilities, our company is dedicated to meticulous production and unwavering quality standards. At Toprakçılar Makina, we offer more than machinery; we provide a commitment to shaping the future of bulgur production and making enduring contributions to the industry with each machine we produce. Our legacy is defined not only by our products but also by the operational efficiency we deliver. As part of the Toprakçılar family, our dedication to innovation and leadership is evident in every aspect of our offerings.



## VİBRO PELET ELEK

VIBRO PELLET SIEVE

# TEKNİK ÇİZİM VE ÖZELLİKLER

## TECHNICAL DRAWING AND FEATURES

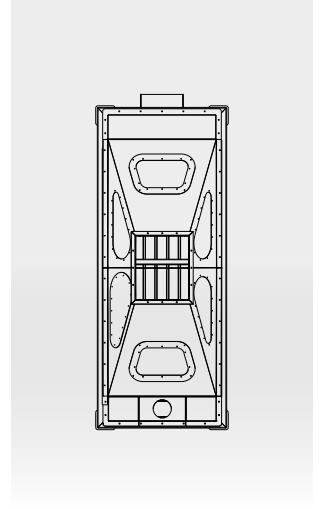
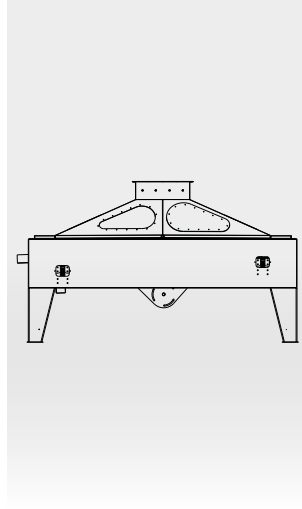
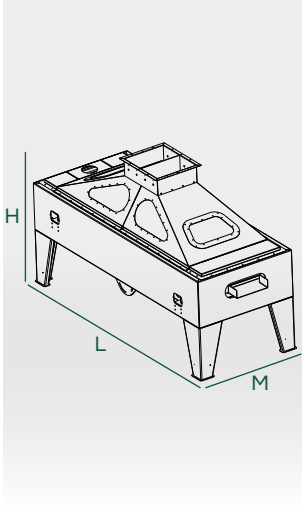

MODEL MODEL	MOTOR GÜCÜ MOTOR POWER	ELEK ÇAPI SIEVE DIAMETER	KAPASİTE CAPACITY	M-L-H
<b>TM-PE25</b>	2x0,94kW	ø4mm	2500Kg/h	<b>M: 1200mm</b> <b>L: 3000mm</b> <b>H: 1800mm</b>
<b>TM-PE50</b>	2x1,2kW	ø4mm	5000Kg/h	<b>M: 1200mm</b> <b>L: 4000mm</b> <b>H: 1800mm</b>



### TR

Pelet eleği, tozu ve küçük veya kırık peletleri ayırmak için kullanılır ve yalnızca istenen boyuttaki peletlerin tutulmasını sağlar. Bu eleme süreci, nihai ürünün kalitesini ve tekdüzelikliğini artırır. Kullanılan eleme sistemine bağlı olarak, farklı boyutlardaki peletler sınıflandırılır ve üretim hattında yeniden işlenmek üzere yeniden dolaştırılır, böylece pelet üretiminde genel üretim verimliliği ve ürün kalitesi iyileştirilir.

### EN

Pellet screen is utilized to separate dust and undersized or broken pellets, ensuring that only pellets of the desired size are retained. This screening process enhances the quality and uniformity of the final product. Depending on the screening system employed, pellets of varying sizes are classified and recirculated for reprocessing in the production line, thereby improving overall production efficiency and product quality in pellet manufacturing.

*Doğadan gelen,  
teknolojiyle şekillenen*

*Coming from nature,  
shaped by technology*



INSTAGRAM



YOUTUBE



WEBSITE



LINKEDIN

[www.toprakcilarmakina.com](http://www.toprakcilarmakina.com)

ORGANİZE SANAYİ BÖLGESİ 13. SOKAK NO:3  
MERKEZ / KARAMAN / TÜRKİYE