

Since 1985

# TOPRAKÇILAR

MAKİNA SANAYİ VE TİC. LTD. ŞTİ

BULGUR ÜRETİM MAKİNALARI

BULGUR PRODUCTION MACHINES

UN DEĞİRMENİ  
FLOUR MILL



[www.toprakcilarmakina.com](http://www.toprakcilarmakina.com)

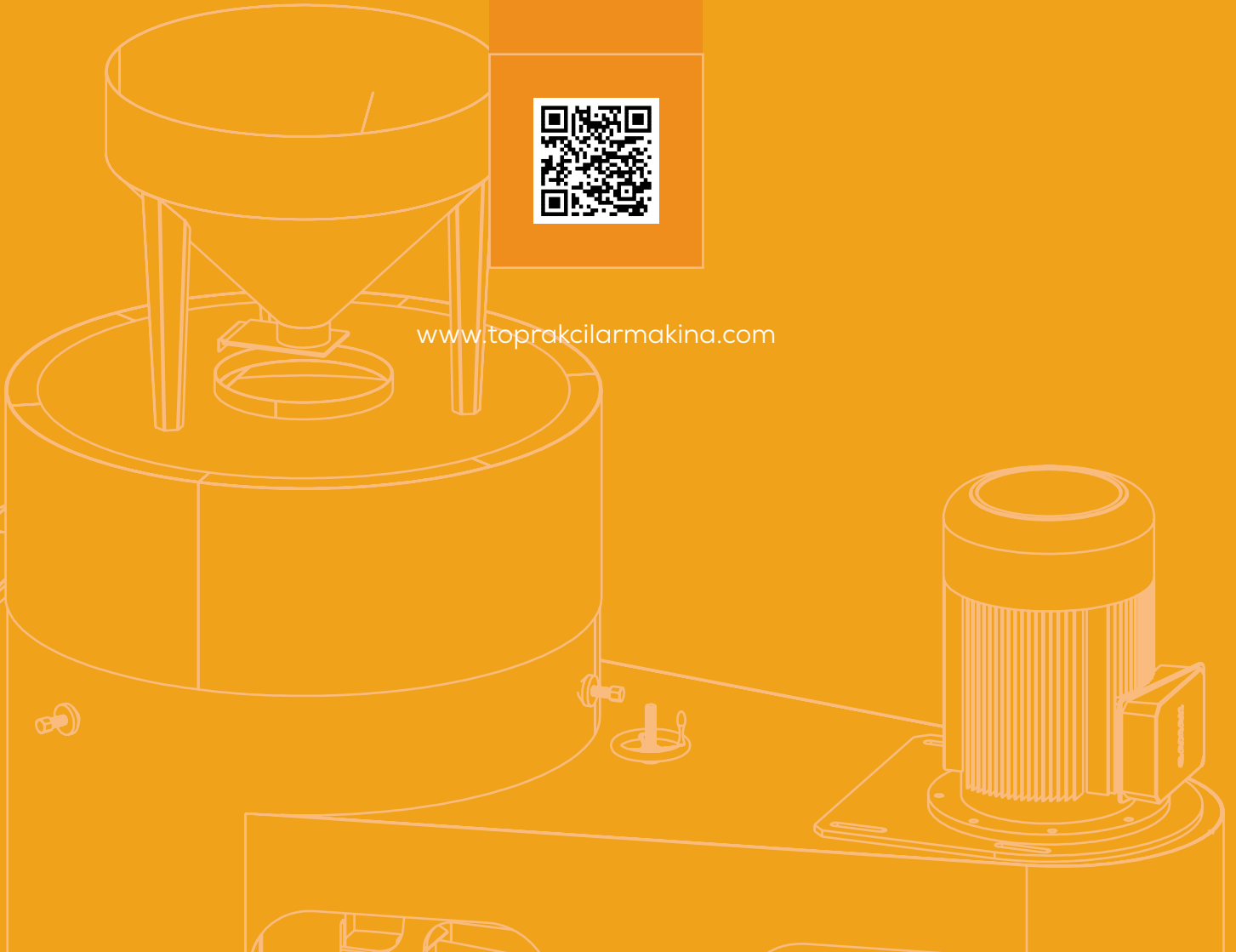

# HAKKIMIZDA

## ABOUT US



### TR

Toprakçılar Makina, 1985'ten beri bulgur, yem ve pelet sektöründe öncü bir kuruluş olup, yenilikçiliği mühendislik uzmanlığıyla harmanlamaktadır. 10.000 m<sup>2</sup> açık ve 4.000 m<sup>2</sup> kapalı alana yayılmış olan firmamız, titiz üretime ve sarsılmaz kalite standartlarına kendini adanmıştır. Toprakçılar Makina olarak, makinelerden daha fazlasını sunuyoruz; ürettiğimiz her makineyle bulgur üretiminin geleceğini şekillendirme ve sektöre kalıcı katkılarda bulunma taahhüdünde bulunuyoruz. Mirasımız yalnızca ürünlerimizle değil, aynı zamanda sağladığımız operasyonel verimlilikle de tanımlanmaktadır. Toprakçılar ailesinin bir parçası olarak, yenilikçiliğe ve liderliğe olan bağlılığımız, tekliflerimizin her noktasında açıkça görülmektedir.

### EN

Toprakçılar Makina has been a leading organization in the bulgur, feed, and pellet sector since 1985, blending innovation with engineering expertise. Spanning 10,000 m<sup>2</sup> of outdoor and 4,000 m<sup>2</sup> of indoor facilities, our company is dedicated to meticulous production and unwavering quality standards. At Toprakçılar Makina, we offer more than machinery; we provide a commitment to shaping the future of bulgur production and making enduring contributions to the industry with each machine we produce. Our legacy is defined not only by our products but also by the operational efficiency we deliver. As part of the Toprakçılar family, our dedication to innovation and leadership is evident in every aspect of our offerings.



UN DEĞİRMENİ

FLOUR MILL

# TEKNİK ÇİZİM VE ÖZELLİKLER

## TECHNICAL DRAWING AND FEATURES

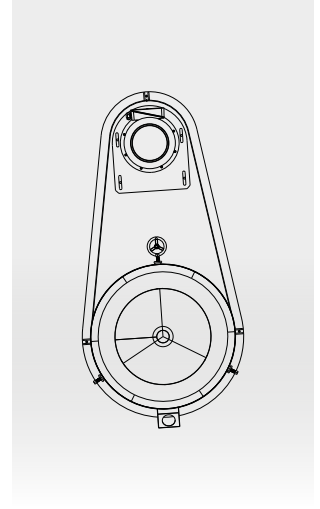
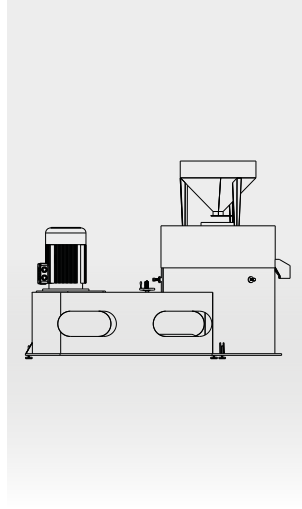
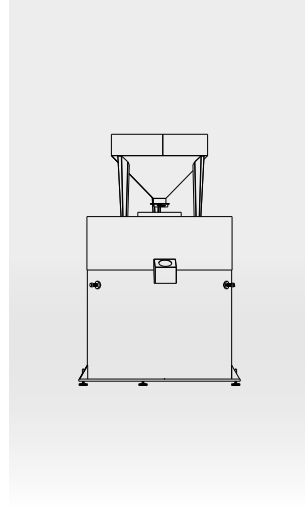
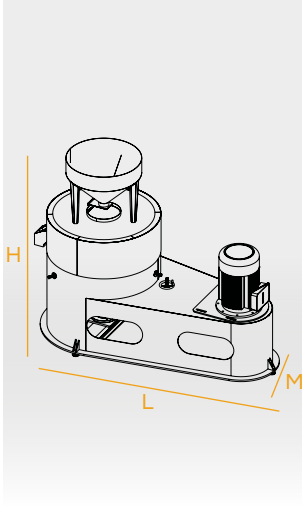

MODEL MODEL	MOTOR GÜCÜ MOTOR POWER	TAŞ ÇAPI STONE DIAMETER	KULLANIM AMACI PURPOSE OF USE	KAPASİTE CAPACITY	M-L-H
TM-UD120	37kW	ø1200 <sup>mm</sup>	Un	400-500Kg/h	M: 1500 <sup>mm</sup> L: 3000 <sup>mm</sup> H: 2300 <sup>mm</sup>



### TR

Un değirmeni, tahılları ince partiküller haline getirerek ekmek, pasta ve diğer unlu mamullerin üretiminde kullanılmak üzere un üretir. Değirmenlerde buğdayın kabukları da ayrılarak kepek gibi yan ürünler elde edilir. Un değirmenleri, gıda sektöründe temel bir rol oynar ve üretim sürecinde hijyenik standartlara uygun şekilde çalışır.

### EN

A flour mill grinds grains into fine particles to produce flour used in the production of bread, pastries, and other baked goods. In the mills, the wheat bran is also separated to obtain by-products such as bran. Flour mills play a fundamental role in the food industry and operate in compliance with hygienic standards throughout the production process.

*Değirmencilik sektöründe  
profesyonel çözümler*

*Professional solutions in  
milling industry*



INSTAGRAM



YOUTUBE



WEBSITE



LINKEDIN

[www.toprakcilarmakina.com](http://www.toprakcilarmakina.com)

ORGANİZE SANAYİ BÖLGESİ 13. SOKAK NO:3  
MERKEZ / KARAMAN / TÜRKİYE