

TOPRAKÇILAR
MAKİNA SANAYİ VE TİC. LTD. ŞTİ

Since 1985

BULGUR ÜRETİM MAKİNALARI
BULGUR PRODUCTION MACHINES

ÖN KURUTMA VAKUMU
PRE-DRYING VACUUM



www.toprakcilarmakina.com

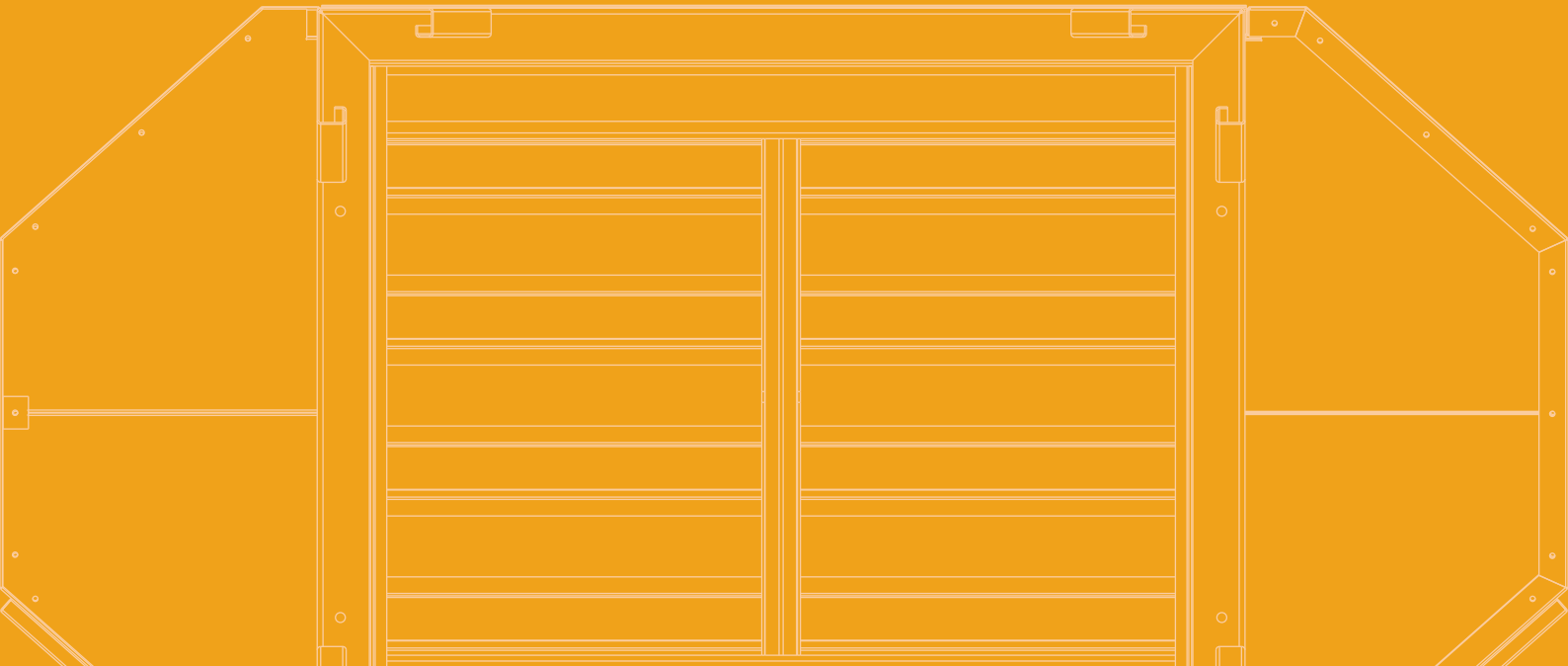

HAKKIMIZDA

ABOUT US



Toprakçılar Makina, 1985 yılından bu yana bulgur, hayvan yemi ve odun peleti sektörlerinde yenilikçi çözümleri mühendislik uzmanlığıyla birleştiren öncü bir makine ve teknoloji tedarikçisidir. 10.000 m² açık ve 4.000 m² kapalı alanı kapsayan tesislerimizde, hassas üretim ve yüksek kalite standartlarını sürdürmeye odaklanıyoruz. Sadece makineler sunmuyoruz; her makine ile bulgur üretiminin geleceğini şekillendirmeye ve sektöre kalıcı katkılar sağlamaya kararlıyız. Ünümüz, yalnızca ürünlerimizin kalitesine değil, aynı zamanda sağladığımız operasyonel verimliliğe dayanmaktadır. Toprakçılar ailesinin bir parçası olarak, yenilik ve liderlik konusundaki bağlılığımız işimizin her yönünde kendini göstermektedir.

Toprakçılar Makina is a leading machinery and technology supplier in the bulgur, animal feed, and wood pellet sectors, combining innovation with engineering expertise since 1985. Our facilities, spanning 10,000 m² outdoors and 4,000 m² indoors, are dedicated to precise production and maintaining high-quality standards. We offer more than just machinery; we are committed to shaping the future of bulgur production and making lasting contributions to the industry with each machine we deliver. Our reputation is built not only on our products but also on the operational efficiency we provide. As part of the Toprakçılar family, our dedication to innovation and leadership is evident in every aspect of our operations.





ÖN KURUTMA VAKUMU

PRE-DRYING VACUUM

TEKNİK ÇİZİM VE ÖZELLİKLER

TECHNICAL DRAWING AND FEATURES

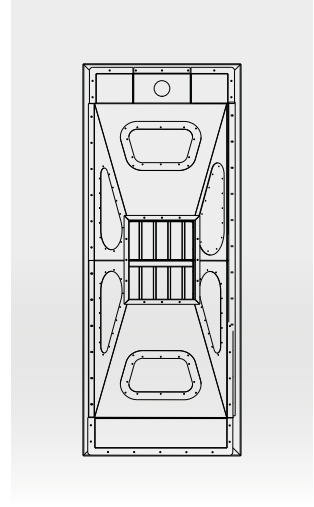
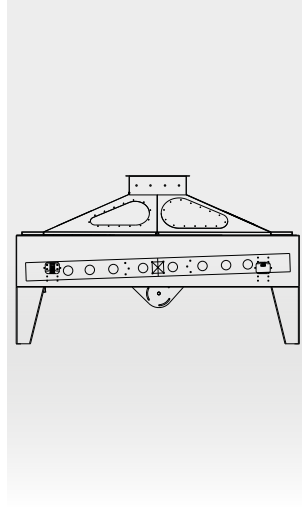
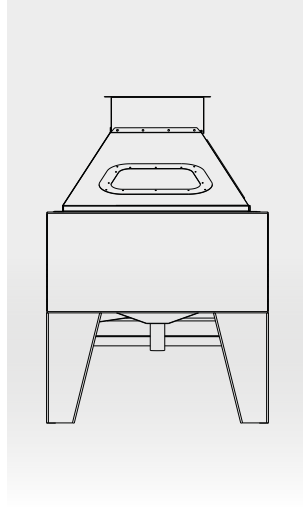
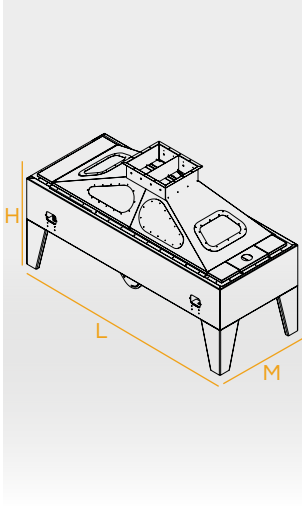

MODEL MODEL	MOTOR GÜCÜ MOTOR POWER	TİPİ TYPE	GÖVDE YAPISI BODY STRUCTURE	KAPASİTE CAPACITY	M-L-H
TM-OKV10	1,1kW	Soğutma kule tipi Cooling tower type	AISI304	1250Kg/h	M: 1200mm L: 3000mm H: 1800mm
TM-OKV25	2x1,1kW	Akışkan yataklı Fluidized bed	AISI304	2500Kg/h	M: 1200mm L: 3000mm H: 1800mm
TM-OKV50	2x1,5kW	Akışkan yataklı Fluidized bed	AISI304	5000Kg/h	M: 1200mm L: 4000mm H: 1800mm



TR

Vakumlu kurutma makinesi, pişmiş bulgurun nem oranını azaltarak kurutma sürecini hızlandırır ve ürün kalitesini artırır. Düşük basınç ortamı oluşturarak, bulgur tanelerindeki nemin buharlaşmasını kolaylaştırır. Buharlaşan nem, vakum sistemi içinde yoğunlaşarak dışarı atılır. Bu işlem, üretim verimliliğini artırırken, bulgurun yüksek kalite standartlarına uygun olmasını sağlar.

EN

A pre-drying vacuum drying machine reduces the moisture content of cooked bulgur, accelerating the main drying process and improving product quality. Creating a low-pressure environment facilitates the evaporation of moisture from the bulgur grains. The evaporated moisture condenses within the vacuum system and is expelled. This process enhances production efficiency and ensures that the bulgur meets high-quality standards.

*Değirmencilik sektöründe
profesyonel çözümler*

*Professional solutions in
milling industry*



INSTAGRAM



YOUTUBE



WEBSITE



LINKEDIN

www.toprakcilarmakina.com

ORGANİZE SANAYİ BÖLGESİ 13. SOKAK NO:3
MERKEZ / KARAMAN / TÜRKİYE