

Since 1985

TOPRAKÇILAR

MAKİNA SANAYİ VE TİC. LTD. ŞTİ

BULGUR ÜRETİM MAKİNALARI

BULGUR PRODUCTION MACHINES

PIŞİRME ÜNİTESİ BUNKERİ
WHEAT COOKING UNIT BUNKER



www.toprakcilarmakina.com

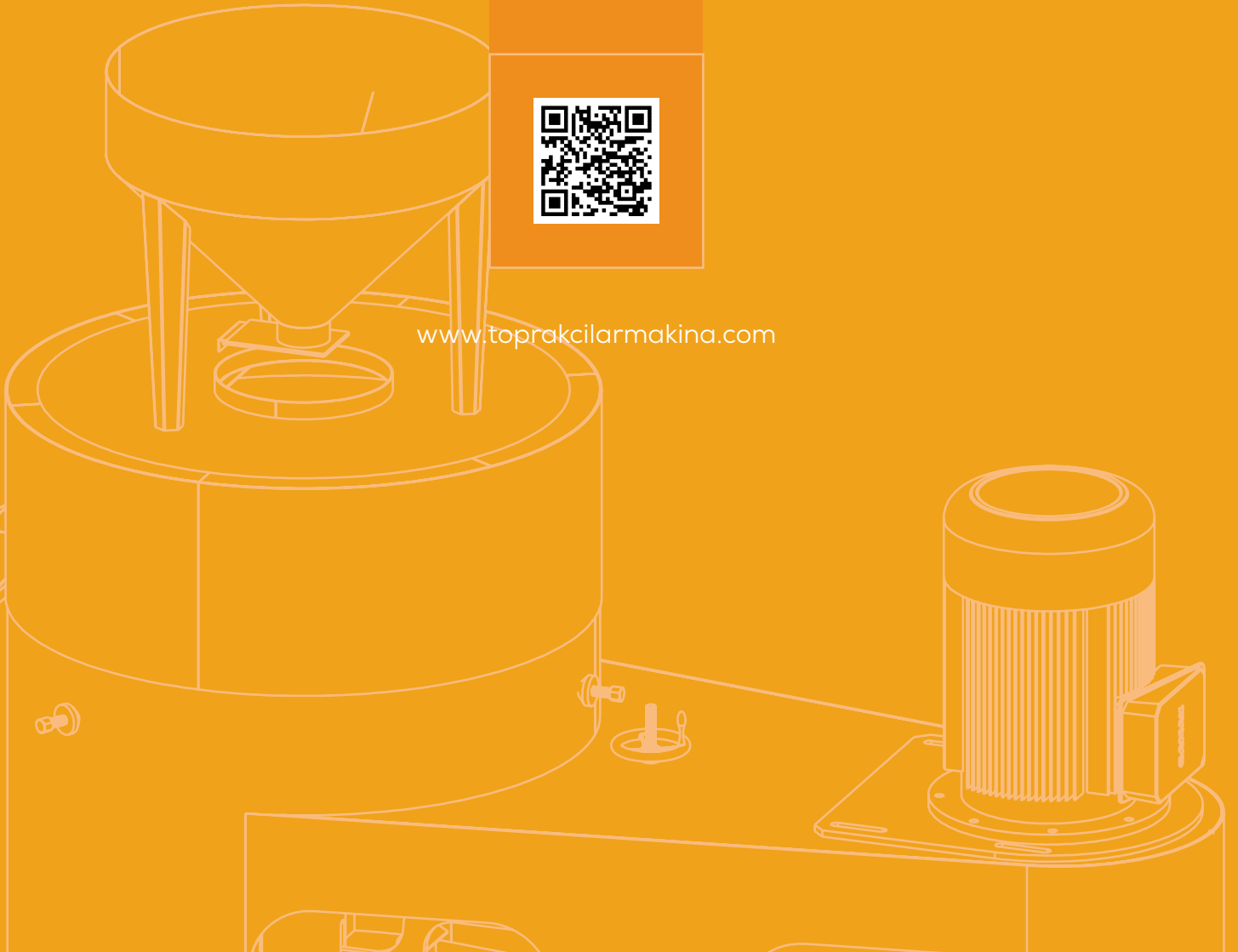

HAKKIMIZDA

ABOUT US



TR

Toprakçılar Makina, 1985'ten beri bulgur, yem ve pelet sektöründe öncü bir kuruluş olup, yenilikçiliği mühendislik uzmanlığıyla harmanlamaktadır. 10.000 m² açık ve 4.000 m² kapalı alana yayılmış olan firmamız, titiz üretime ve sarsılmaz kalite standartlarına kendini adanmıştır. Toprakçılar Makina olarak, makinelerden daha fazlasını sunuyoruz; ürettiğimiz her makineyle bulgur üretiminin geleceğini şekillendirme ve sektöre kalıcı katkılarda bulunma taahhüdünde bulunuyoruz. Mirasımız yalnızca ürünlerimizle değil, aynı zamanda sağladığımız operasyonel verimlilikle de tanımlanmaktadır. Toprakçılar ailesinin bir parçası olarak, yenilikçiliğe ve liderliğe olan bağlılığımız, tekliflerimizin her noktasında açıkça görülmektedir.

EN

Toprakçılar Makina has been a leading organization in the bulgur, feed, and pellet sector since 1985, blending innovation with engineering expertise. Spanning 10,000 m² of outdoor and 4,000 m² of indoor facilities, our company is dedicated to meticulous production and unwavering quality standards. At Toprakçılar Makina, we offer more than machinery; we provide a commitment to shaping the future of bulgur production and making enduring contributions to the industry with each machine we produce. Our legacy is defined not only by our products but also by the operational efficiency we deliver. As part of the Toprakçılar family, our dedication to innovation and leadership is evident in every aspect of our offerings.



PIŞİRME ÜNİTESİ BUNKERİ

WHEAT COOKING UNIT BUNKER

TEKNİK ÇİZİM VE ÖZELLİKLER

TECHNICAL DRAWING AND FEATURES

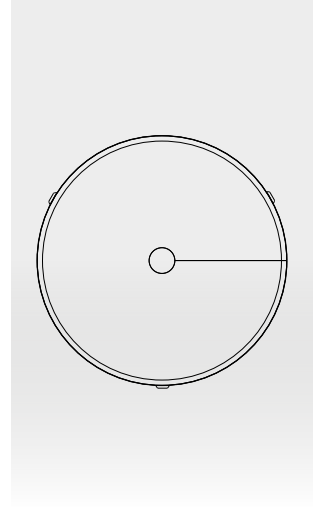
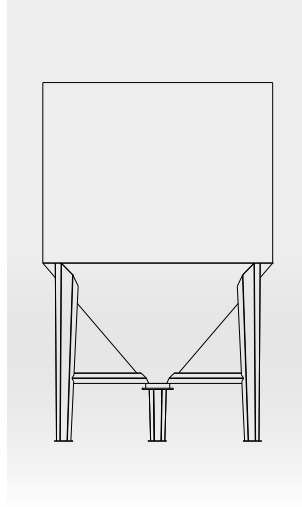
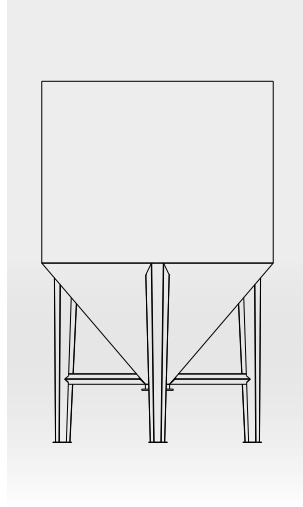
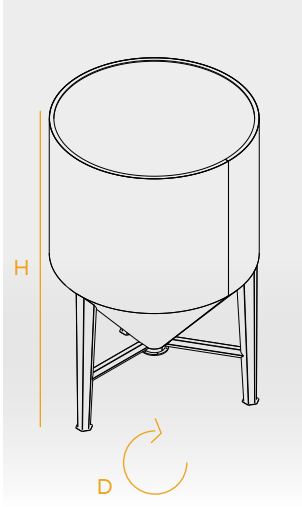

MODEL MODEL	TİPİ TYPE	GÖVDE YAPISI BODY STRUCTURE	AKTARMA TİPİ TRANSMISSION TYPE	KAPASİTE CAPACITY	D-H
TM-PUB25	Silindirik (Cylindrical) / Konik (Conical)	304 AISI SS	Helezonlu (Helical) / Doğal Akış (Natural Flow)	2500Kg/h	D: 1900mm H: 2800mm
TM-PUB30	Silindirik (Cylindrical) / Konik (Conical)	304 AISI SS	Helezonlu (Helical) / Doğal Akış (Natural Flow)	3000Kg/h	D: 1900mm H: 3200mm
TM-PUB50	Silindirik (Cylindrical) / Konik (Conical)	304 AISI SS	Helezonlu (Helical) / Doğal Akış (Natural Flow)	5000Kg/h	D: 2400mm H: 3000mm
TM-PUB75	Silindirik (Cylindrical) / Konik (Conical)	304 AISI SS	Helezonlu (Helical) / Doğal Akış (Natural Flow)	7500Kg/h	D: 2800mm H: 3000mm



TR

Ürün depolama ve bekletme istasyonları, bulgur tesisinin kapasitesine göre hacmi hesaplanan silindirik konik yapıya sahiptir. Küf ve mantar gibi oluşumlara gelişme ortamı sağlamamak için özel açılar ve ölçülerle imal edilir. Bu istasyonlar, ürünlerin kalitesini koruyarak uzun süreli depolama sağlar. Ayrıca, hijyenik koşulları maksimum düzeyde tutarak, ürünlerin güvenli bir şekilde bekletilmesine imkan tanır. Üretim süreçlerinin kesintisiz ve verimli bir şekilde devam etmesini destekler.

EN

Product storage and holding stations are cylindrical conical structures with volume calculated according to the capacity of the bulgur facility. They are manufactured with special angles and dimensions to prevent the growth of mold and fungi. These stations maintain the quality of the products, enabling long-term storage. Additionally, they ensure maximum hygienic conditions, allowing for safe storage of the products. They support continuous and efficient production processes.

*Değirmencilik sektöründe
profesyonel çözümler*

*Professional solutions in
milling industry*



INSTAGRAM



YOUTUBE



WEBSITE



LINKEDIN

www.toprakcilarmakina.com

ORGANİZE SANAYİ BÖLGESİ 13. SOKAK NO:3
MERKEZ / KARAMAN / TÜRKİYE