

Since 1985

TOPRAKÇILAR

MAKİNA SANAYİ VE TİC. LTD. ŞTİ

BULGUR ÜRETİM MAKİNALARI

BULGUR PRODUCTION MACHINES

PNOMATİK SÜRGÜ
PNEUMATIC SLIDERS



www.toprakcilarmakina.com

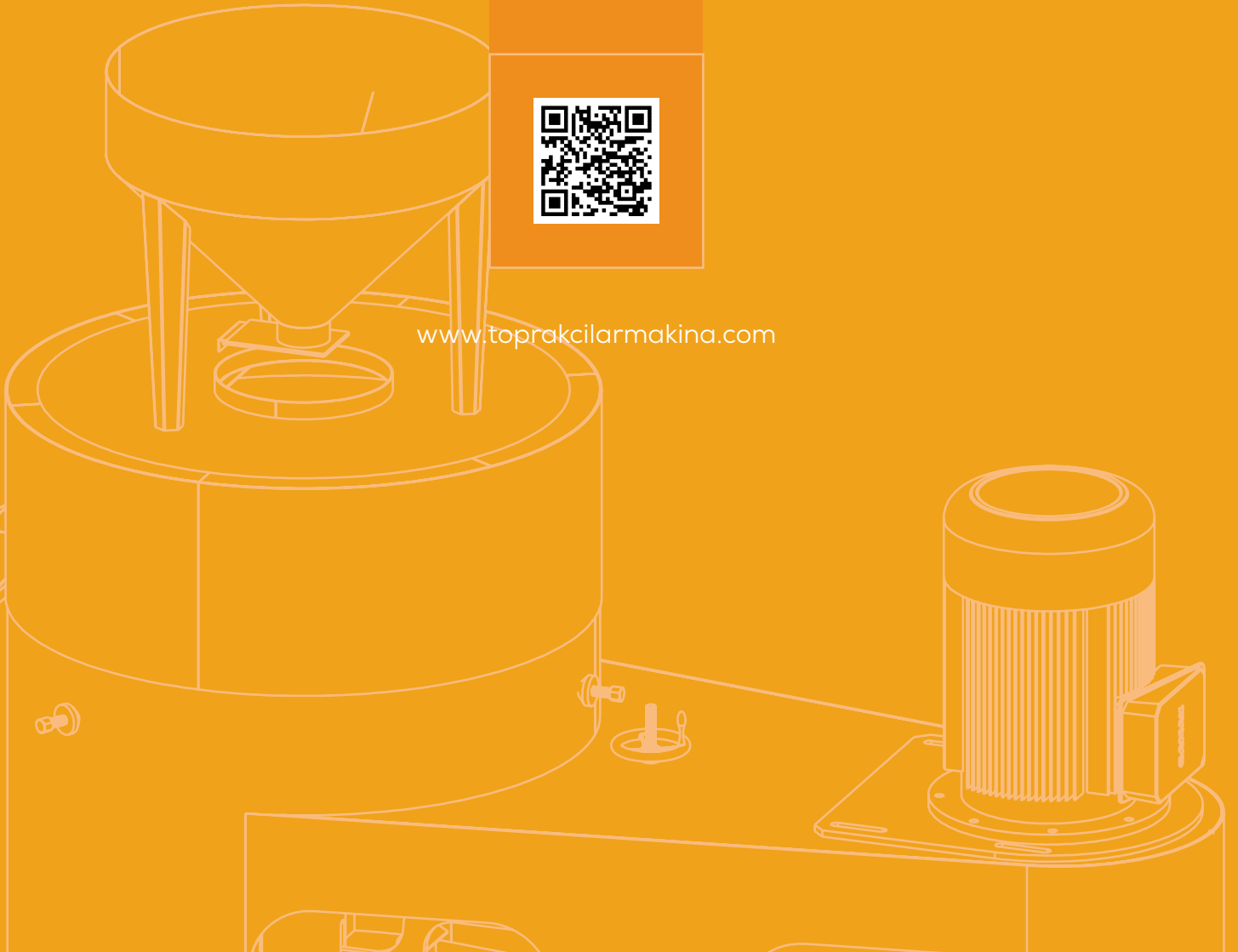

HAKKIMIZDA

ABOUT US



TR

Toprakçılar Makina, 1985'ten beri bulgur, yem ve pelet sektöründe öncü bir kuruluş olup, yenilikçiliği mühendislik uzmanlığıyla harmanlamaktadır. 10.000 m² açık ve 4.000 m² kapalı alana yayılmış olan firmamız, titiz üretime ve sarsılmaz kalite standartlarına kendini adanmıştır. Toprakçılar Makina olarak, makinelerden daha fazlasını sunuyoruz; ürettiğimiz her makineyle bulgur üretiminin geleceğini şekillendirme ve sektöre kalıcı katkılarda bulunma taahhüdünde bulunuyoruz. Mirasımız yalnızca ürünlerimizle değil, aynı zamanda sağladığımız operasyonel verimlilikle de tanımlanmaktadır. Toprakçılar ailesinin bir parçası olarak, yenilikçiliğe ve liderliğe olan bağlılığımız, tekliflerimizin her noktasında açıkça görülmektedir.

EN

Toprakçılar Makina has been a leading organization in the bulgur, feed, and pellet sector since 1985, blending innovation with engineering expertise. Spanning 10,000 m² of outdoor and 4,000 m² of indoor facilities, our company is dedicated to meticulous production and unwavering quality standards. At Toprakçılar Makina, we offer more than machinery; we provide a commitment to shaping the future of bulgur production and making enduring contributions to the industry with each machine we produce. Our legacy is defined not only by our products but also by the operational efficiency we deliver. As part of the Toprakçılar family, our dedication to innovation and leadership is evident in every aspect of our offerings.

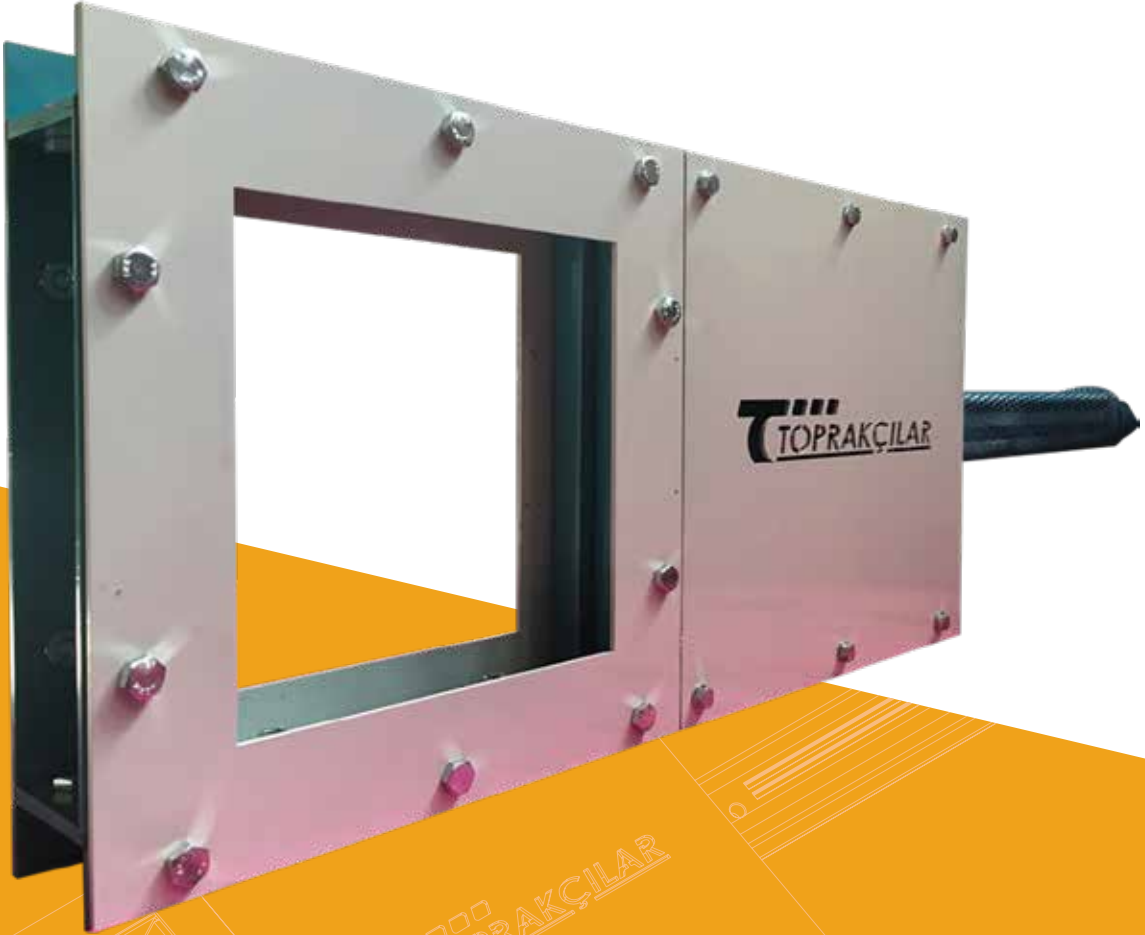

PNOMATİK SÜRGÜ

PNEUMATIC SLIDERS

TEKNİK ÇİZİM VE ÖZELLİKLER

TECHNICAL DRAWING AND FEATURES

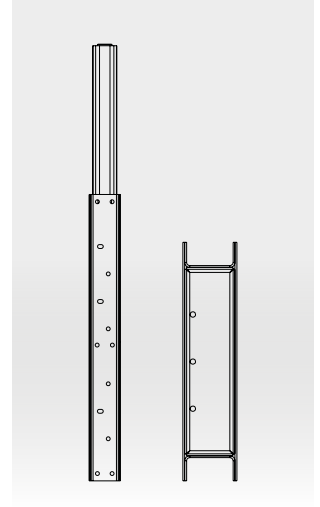
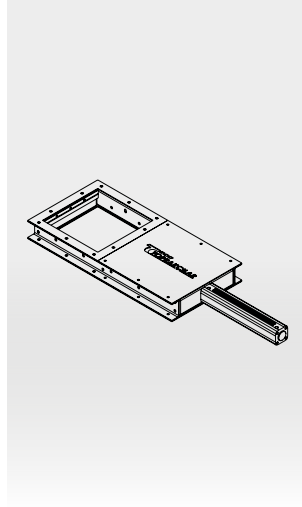
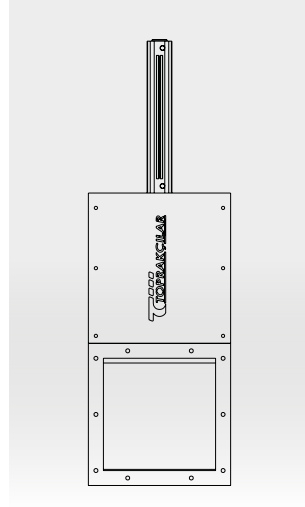
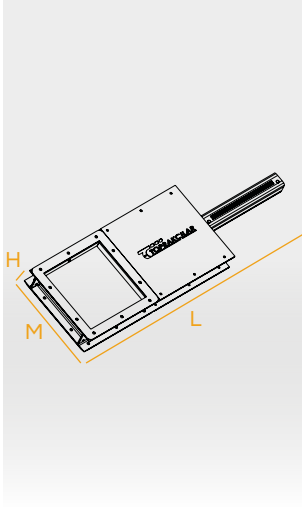

MODEL MODEL	PİSTON ÇAP PISTON DIAMETER	PİSTON UZUNLUĞU PISTON LENGTH	KLEPE AĞZI VALVE MOUTH	M-L-H
TM-PS20	ø40mm	200mm	200mmx 200mm	M: 280mm L: 750mm H: 86mm
TM-PS30	ø40mm	300mm	300mmx 300mm	M: 380mm L: 1100mm H: 86mm
TM-PS35	ø50mm	350mm	350mmx 350mm	M: 430mm L: 1200mm H: 86mm
TM-PS40	ø63mm	400mm	400mmx 400mm	M: 600mm L: 1700mm H: 100mm
TM-PS50	ø63mm	500mm	500mmx 500mm	M: 600mm L: 1830mm H: 100mm



TR

Pnömatik sürgü, malzemelerin akışını kontrol etmek için kullanılır. Sıkıştırılmış hava kullanarak kayan bir kapıyı açar ve kapatır, böylece malzeme boşaltımını hassas bir şekilde kontrol eder. Pnömatik sürgüler, tıkanma riskini azaltarak ve düzgün çalışmayı sağlayarak güvenilir performans sunar. Malzeme taşıma sistemlerinde verimlilik ve üretkenliği artırmaya katkıda bulunur.

EN

Pneumatic slide gate is used to control the flow of materials. It uses compressed air to open and close a sliding gate, allowing for precise control of material discharge. Pneumatic slide gates provide reliable performance by reducing the risk of blockages and ensuring smooth operation. They contribute to increased efficiency and productivity in material handling systems.

*Değirmencilik sektöründe
profesyonel çözümler*

*Professional solutions in
milling industry*



INSTAGRAM



YOUTUBE



WEBSITE



LINKEDIN

www.toprakcilarmakina.com

ORGANİZE SANAYİ BÖLGESİ 13. SOKAK NO:3
MERKEZ / KARAMAN / TÜRKİYE