

TOPRAKÇILAR *Since 1985*
MAKİNA SANAYİ VE TİC. LTD. ŞTİ

BULGUR ÜRETİM MAKİNALARI
BULGUR PRODUCTION MACHINES

YÜKLEME HELEZONU
TRANSPORT SPIRAL CONVEYOR



www.toprakcilarmakina.com

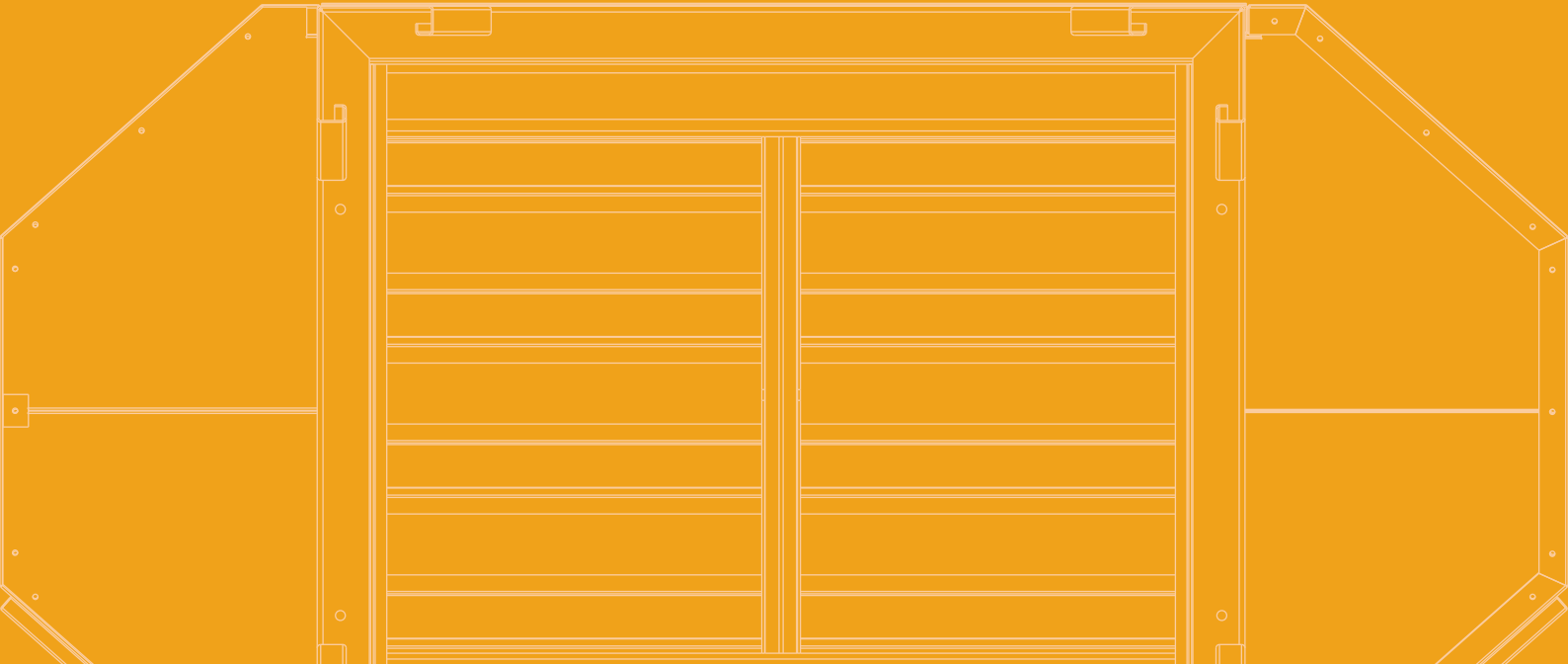

HAKKIMIZDA

ABOUT US



Toprakçılar Makina, 1985 yılından bu yana bulgur, hayvan yemi ve odun peleti sektörlerinde yenilikçi çözümleri mühendislik uzmanlığıyla birleştiren öncü bir makine ve teknoloji tedarikçisidir. 10.000 m² açık ve 4.000 m² kapalı alanı kapsayan tesislerimizde, hassas üretim ve yüksek kalite standartlarını sürdürmeye odaklanıyoruz. Sadece makineler sunmuyoruz; her makine ile bulgur üretiminin geleceğini şekillendirmeye ve sektöre kalıcı katkılar sağlamaya kararlıyız. Ünümüz, yalnızca ürünlerimizin kalitesine değil, aynı zamanda sağladığımız operasyonel verimliliğe dayanmaktadır. Toprakçılar ailesinin bir parçası olarak, yenilik ve liderlik konusundaki bağlılığımız işimizin her yönünde kendini göstermektedir.

Toprakçılar Makina is a leading machinery and technology supplier in the bulgur, animal feed, and wood pellet sectors, combining innovation with engineering expertise since 1985. Our facilities, spanning 10,000 m² outdoors and 4,000 m² indoors, are dedicated to precise production and maintaining high-quality standards. We offer more than just machinery; we are committed to shaping the future of bulgur production and making lasting contributions to the industry with each machine we deliver. Our reputation is built not only on our products but also on the operational efficiency we provide. As part of the Toprakçılar family, our dedication to innovation and leadership is evident in every aspect of our operations.



INDUSTRIAL BULGUR MACHINES

Since 1985
TÖPRAKÇILAR
MAKİNA SANAYİ VE TİC. LTD. ŞTİ



YÜKLEME HELEZONU

TRANSPORT SPIRAL CONVEYOR

TEKNİK ÇİZİM VE ÖZELLİKLER

TECHNICAL DRAWING AND FEATURES

www.toprakcilarmakina.com

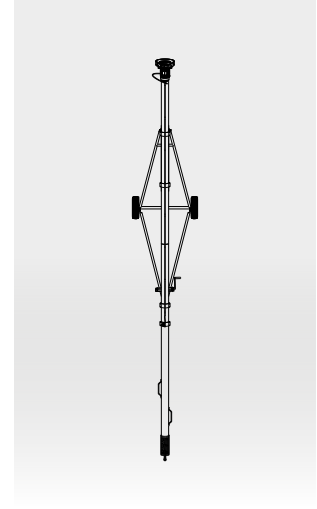
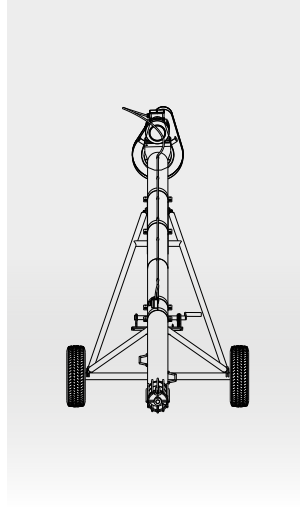
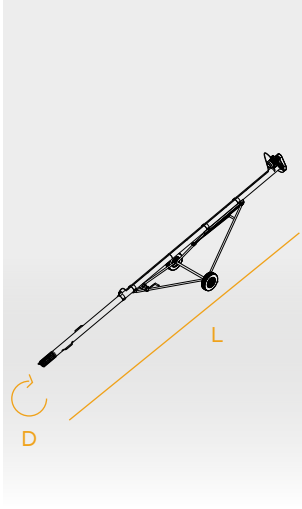

MODEL MODEL	MOTOR GÜCÜ MOTOR POWER	HELEZON YAPRAK ÇAPI SPIRAL LEAF DIAMETER	MİNİMUM MAXİMUM YÜKSEKLİK MINIMUM MAXIMUM HEIGHT	AKS UZUNLUK AXIS LENGTH	D-L
TM-NH4	4kW	ø140mm	min: 1600 ^{mm} max: 3000 ^{mm}	2200 ^{mm}	D: 168 ^{mm} L: 8000 ^{mm}
TM-NH55	5,5kW	ø140mm	min: 2100 ^{mm} max: 3500 ^{mm}	2200 ^{mm}	D: 168 ^{mm} L: 10000 ^{mm}
TM-NH75	7,5kW	ø200mm	min: 2500 ^{mm} max: 4500 ^{mm}	2200 ^{mm}	D: 168 ^{mm} L: 12000 ^{mm}



TR

Nakliye helezonları, taneli ürün ve benzeri malzemelerin doldurma ve boşaltma işlemleri için kullanılır. Kayış kasnak destekli çift helezon sistemi sayesinde, farklı uzunluklarda ve kapasitede üretilebilir. Bu sistem, statik olarak uygun bir şekilde çalışır. Böylece, malzeme taşımada yüksek verimlilik sağlar.

EN

Transport Spiral Conveyors by Toprakçılar Makina are designed for efficient filling and unloading operations of granular products and similar materials. Featuring a double spiral system supported by a belt and pulley mechanism, these transport spirals can be customized in various lengths and capacities to suit specific operational needs. The system is engineered for static stability, ensuring smooth and reliable material handling. This design maximizes efficiency in material transportation, offering a high-performance solution for bulk handling applications in the food processing and agricultural industries.

*Değirmencilik sektöründe
profesyonel çözümler*

*Professional solutions in
milling industry*



INSTAGRAM



YOUTUBE



WEBSITE



LINKEDIN

www.toprakcilarmakina.com

ORGANİZE SANAYİ BÖLGESİ 13. SOKAK NO:3
MERKEZ / KARAMAN / TÜRKİYE