

TOPRAKÇILAR *Since 1985*
MAKİNA SANAYİ VE TİC. LTD. ŞTİ

BULGUR ÜRETİM MAKİNALARI
BULGUR PRODUCTION MACHINES

ÖN TEMİZLEME SEPERATÖRÜ
PRE-CLEANING SEPARATOR



www.toprakcilarmakina.com

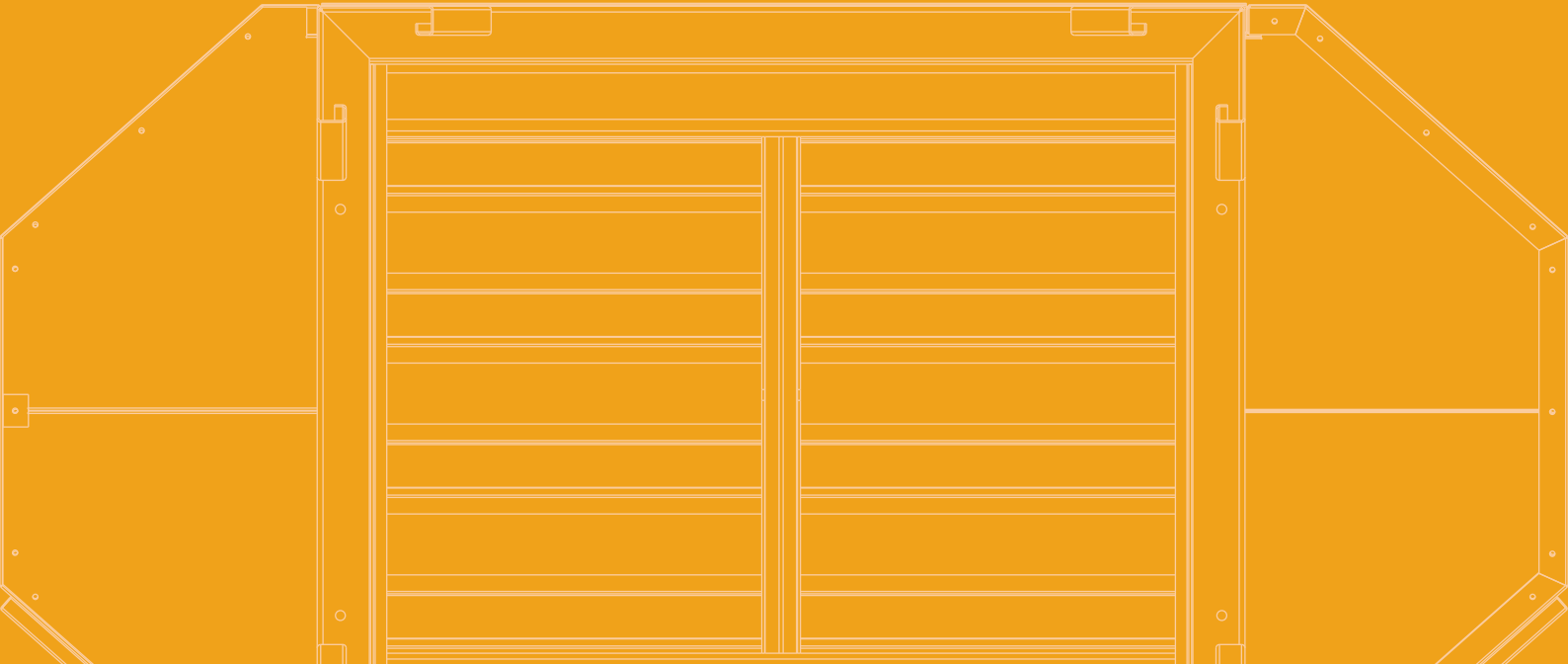

HAKKIMIZDA

ABOUT US



Toprakçılar Makina, 1985 yılından bu yana bulgur, hayvan yemi ve odun peleti sektörlerinde yenilikçi çözümleri mühendislik uzmanlığıyla birleştiren öncü bir makine ve teknoloji tedarikçisidir. 10.000 m² açık ve 4.000 m² kapalı alanı kapsayan tesislerimizde, hassas üretim ve yüksek kalite standartlarını sürdürmeye odaklanıyoruz. Sadece makineler sunmuyoruz; her makine ile bulgur üretiminin geleceğini şekillendirmeye ve sektöre kalıcı katkılar sağlamaya kararlıyız. Ünümüz, yalnızca ürünlerimizin kalitesine değil, aynı zamanda sağladığımız operasyonel verimliliğe dayanmaktadır. Toprakçılar ailesinin bir parçası olarak, yenilik ve liderlik konusundaki bağlılığımız işimizin her yönünde kendini göstermektedir.

Toprakçılar Makina is a leading machinery and technology supplier in the bulgur, animal feed, and wood pellet sectors, combining innovation with engineering expertise since 1985. Our facilities, spanning 10,000 m² outdoors and 4,000 m² indoors, are dedicated to precise production and maintaining high-quality standards. We offer more than just machinery; we are committed to shaping the future of bulgur production and making lasting contributions to the industry with each machine we deliver. Our reputation is built not only on our products but also on the operational efficiency we provide. As part of the Toprakçılar family, our dedication to innovation and leadership is evident in every aspect of our operations.





ÖN TEMİZLEME SEPERATÖRÜ

PRE-CLEANING SEPARATOR

TEKNİK ÇİZİM VE ÖZELLİKLER

TECHNICAL DRAWING AND FEATURES

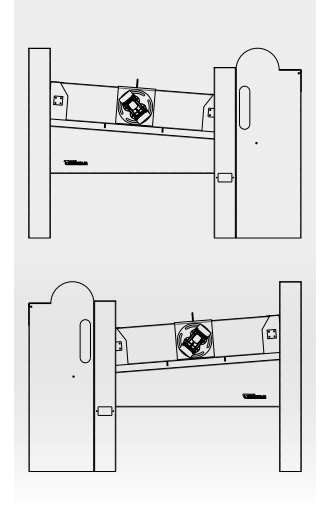
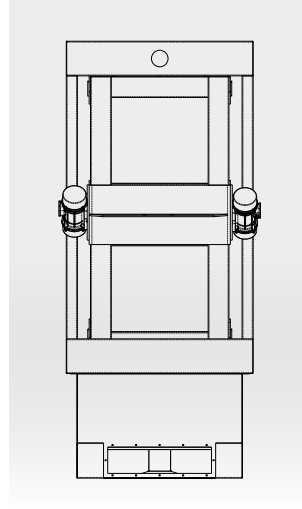
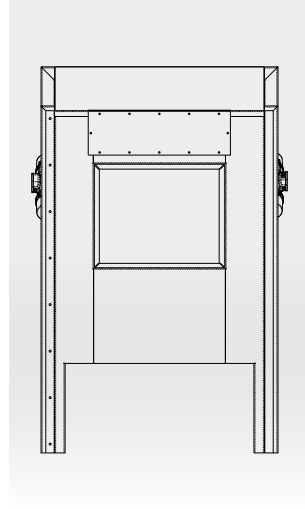
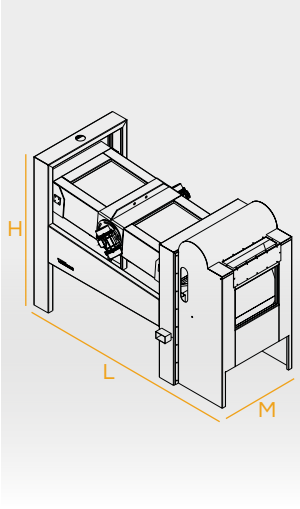

MODEL MODEL	MOTOR GÜCÜ MOTOR POWER	HAVA KANALI AIR DUCT	ELEME ALANI SCREENING AREA	KAPASİTE CAPACITY	M-L-H
TM-OTS10	0,55kw	Yok N/A	Tek kat Single layer	1000Kg/h	M: 1250mm L: 2400mm H: 1750mm
TM-OTS25H	2x0,95kw	Var N/A	Çift kat Double layer	2500Kg/h	M: 1350mm L: 3150mm H: 2200mm
TM-OTS50H	2x1,1kw	Var Available	Çift kat Double layer	5000Kg/h	M: 1350mm L: 3600mm H: 2200mm



TR

Ön temizleme seperatörü, tarımsal ürünlerin işlenmesinde önemli bir rol oynar. Hasat sonrası ürünlerin ilk aşamada yabancı maddelerden arındırılmasını sağlar. Tohumlar, saman, taşlar ve diğer istenmeyen parçacıkları ayırarak ürünlerin kalitesini artırır ve sonraki işlemler için hazır hale getirir. Ön temizleme seperatörleri, titreşim veya hava akımı gibi yöntemlerle çalışır ve bu yöntemler ürünün homojen bir şekilde temizlenmesini sağlar.

EN

Pre-cleaning separators play an important role in the processing of granular cereal products. It ensures that the products are cleaned of foreign materials in the first stage after harvest. It increases the quality of the products by separating seeds, straw, stones and other unwanted particles and making them ready for the next processes. Pre-cleaning separators work with methods such as vibration or air flow and these methods ensure that the product is cleaned homogeneously.

*Değirmencilik sektöründe
profesyonel çözümler*

*Professional solutions in
milling industry*



INSTAGRAM



YOUTUBE



WEBSITE



LINKEDIN

www.toprakcilarmakina.com

ORGANİZE SANAYİ BÖLGESİ 13. SOKAK NO:3
MERKEZ / KARAMAN / TÜRKİYE