

TOPRAKÇILAR
MAKİNA SANAYİ VE TİC. LTD. ŞTİ

Since 1985

BULGUR ÜRETİM MAKİNALARI
BULGUR PRODUCTION MACHINES

**TAŞ DEĞİRMEN
STONE MILL**



www.toprakcilarmakina.com

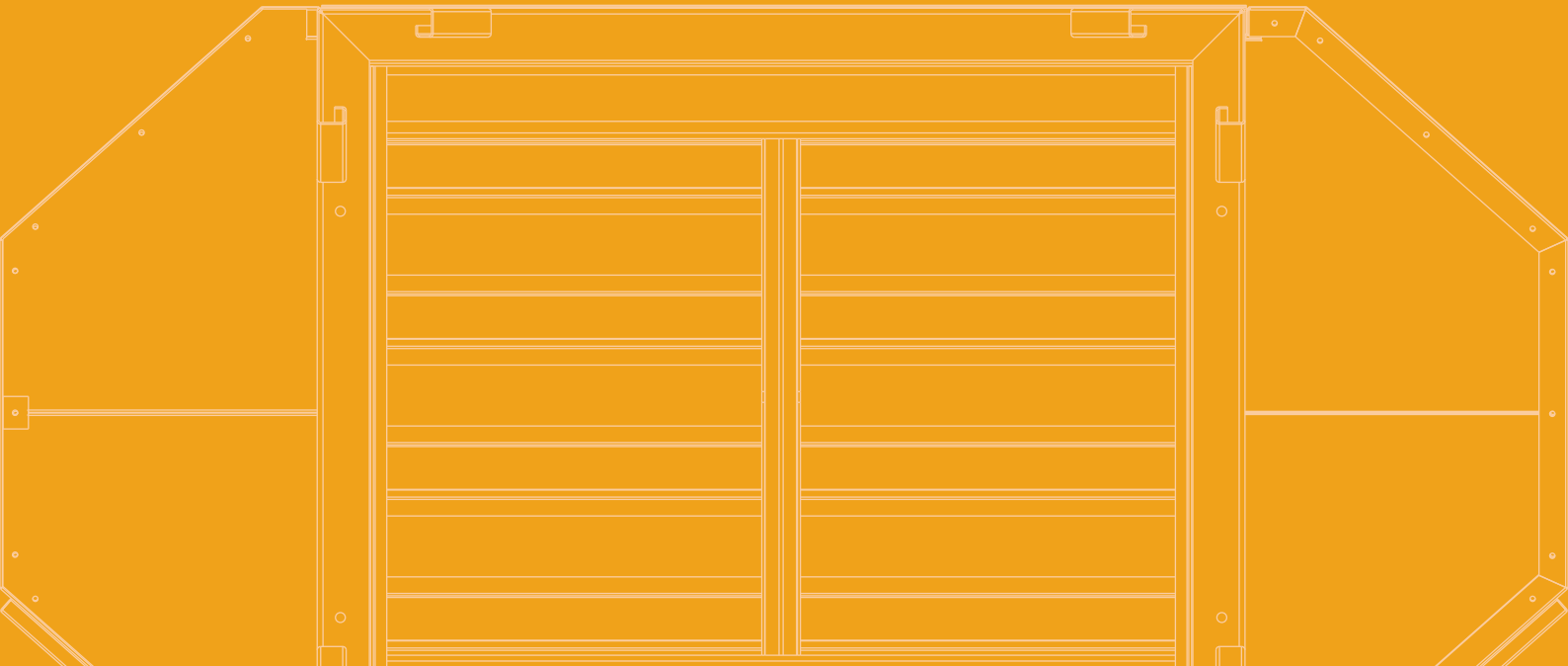

HAKKIMIZDA

ABOUT US



Toprakçılar Makina, 1985 yılından bu yana bulgur, hayvan yemi ve odun peleti sektörlerinde yenilikçi çözümleri mühendislik uzmanlığıyla birleştiren öncü bir makine ve teknoloji tedarikçisidir. 10.000 m² açık ve 4.000 m² kapalı alanı kapsayan tesislerimizde, hassas üretim ve yüksek kalite standartlarını sürdürmeye odaklanıyoruz. Sadece makineler sunmuyoruz; her makine ile bulgur üretiminin geleceğini şekillendirmeye ve sektöre kalıcı katkılar sağlamaya kararlıyız. Ünümüz, yalnızca ürünlerimizin kalitesine değil, aynı zamanda sağladığımız operasyonel verimliliğe dayanmaktadır. Toprakçılar ailesinin bir parçası olarak, yenilik ve liderlik konusundaki bağlılığımız işimizin her yönünde kendini göstermektedir.

Toprakçılar Makina is a leading machinery and technology supplier in the bulgur, animal feed, and wood pellet sectors, combining innovation with engineering expertise since 1985. Our facilities, spanning 10,000 m² outdoors and 4,000 m² indoors, are dedicated to precise production and maintaining high-quality standards. We offer more than just machinery; we are committed to shaping the future of bulgur production and making lasting contributions to the industry with each machine we deliver. Our reputation is built not only on our products but also on the operational efficiency we provide. As part of the Toprakçılar family, our dedication to innovation and leadership is evident in every aspect of our operations.





TAŞ DEĞİRMEN

STONE MILL

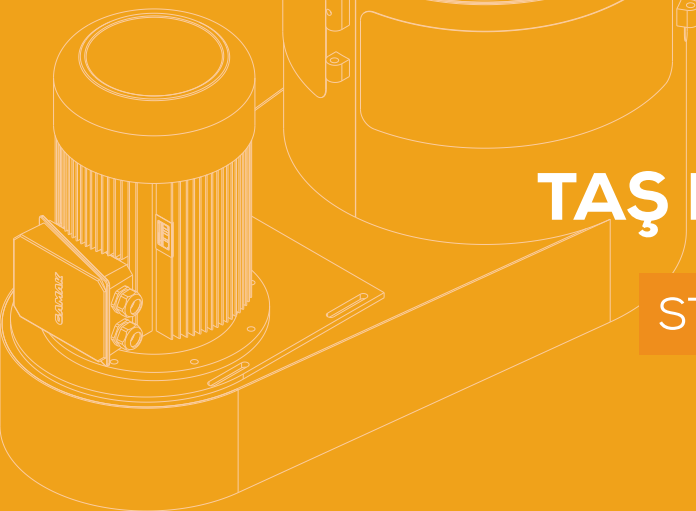

TEKNİK ÇİZİM VE ÖZELLİKLER

TECHNICAL DRAWING AND FEATURES

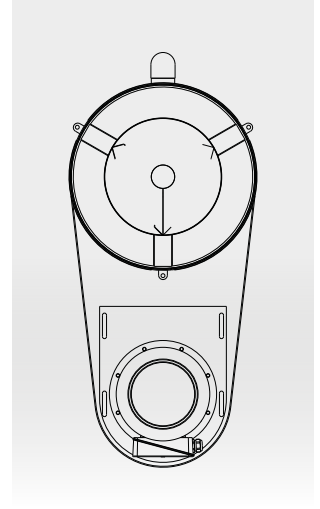
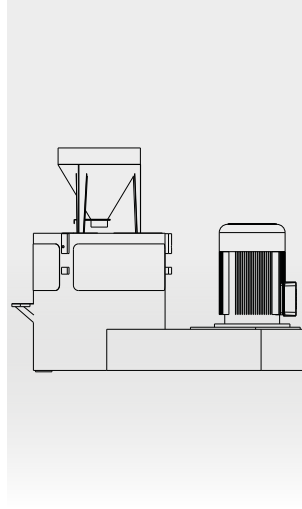
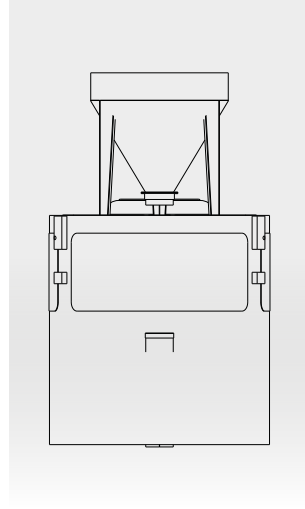
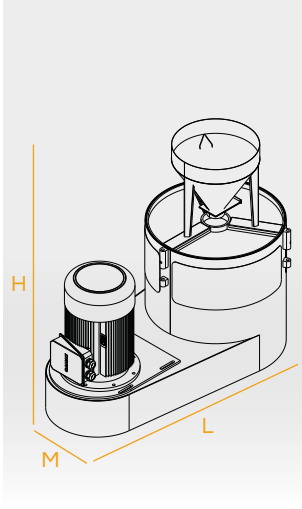

www.toprakcilarmakina.com

MODEL MODEL	MOTOR GÜCÜ MOTOR POWER	TAŞ ÇAPI STONE DIAMETER	KULLANIM AMACI PURPOSE OF USE	KAPASİTE CAPACITY	M-L-H
TM-TD40	11kW	ø400 ^{mm}	Bulgur	150-250Kg/h	M: 575 ^{mm} L: 1250 ^{mm} H: 1100 ^{mm}
TM-TD80	37kW	ø800 ^{mm}	Bulgur	350-550Kg/h	M: 1000 ^{mm} L: 2000 ^{mm} H: 1600 ^{mm}



TR

Taş değirmen, iki büyük taş arasında buğdayı öğütür ve taşlardaki dişli yapılar sayesinde buğday tanelerini parçalara ayırır. Taş değirmenlerin avantajı, düşük ısınma ile buğdayın doğal özelliklerinin korunması ve besin değerlerinin kaybolmamasıdır. Bu yöntem, özellikle doğal ve geleneksel üretimle üretilen bulgurlar için tercih edilir.

EN

The stone mill produces bulgur by grinding wheat between two large stones and separating the wheat grains into pieces thanks to the toothed structures on the stones. The advantage of stone mills is that the natural characteristics and nutritional values of wheat are preserved due to low heating. The stone mill is especially preferred for bulgur produced with natural and traditional production process.

*Değirmencilik sektöründe
profesyonel çözümler*

*Professional solutions in
milling industry*



INSTAGRAM



YOUTUBE



WEBSITE



LINKEDIN

www.toprakcilarmakina.com

ORGANİZE SANAYİ BÖLGESİ 13. SOKAK NO:3
MERKEZ / KARAMAN / TÜRKİYE