

Since 1985

TOPRAKÇILAR

MAKİNA SANAYİ VE TİC. LTD. ŞTİ

BULGUR ÜRETİM MAKİNALARI

BULGUR PRODUCTION MACHINES

TAŞ DEĞİRMEN
STONE MILL



www.toprakcilarmakina.com

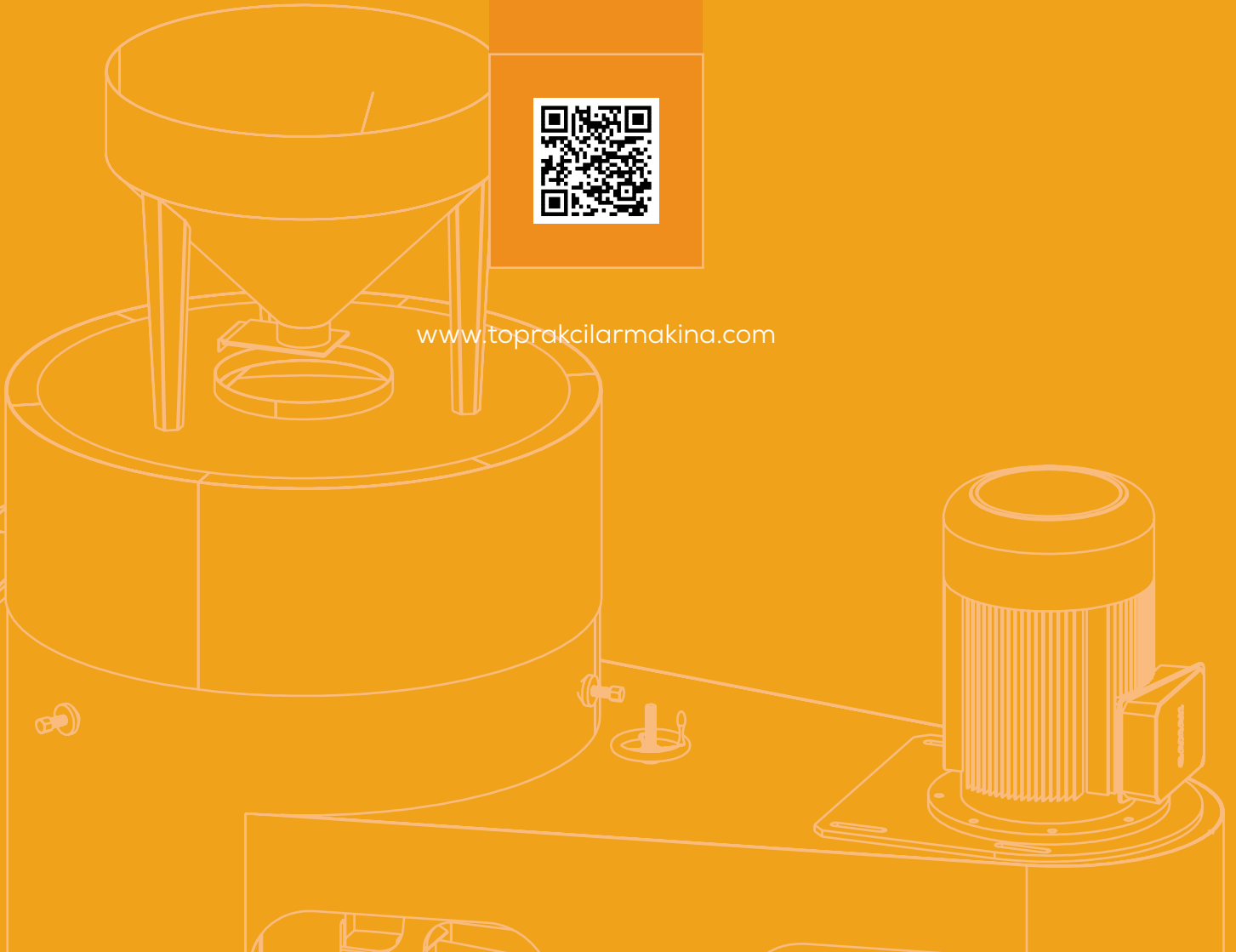

HAKKIMIZDA

ABOUT US



TR

Toprakçılar Makina, 1985'ten beri bulgur, yem ve pelet sektöründe öncü bir kuruluş olup, yenilikçiliği mühendislik uzmanlığıyla harmanlamaktadır. 10.000 m² açık ve 4.000 m² kapalı alana yayılmış olan firmamız, titiz üretime ve sarsılmaz kalite standartlarına kendini adanmıştır. Toprakçılar Makina olarak, makinelerden daha fazlasını sunuyoruz; ürettiğimiz her makineyle bulgur üretiminin geleceğini şekillendirme ve sektöre kalıcı katkılarda bulunma taahhüdünde bulunuyoruz. Mirasımız yalnızca ürünlerimizle değil, aynı zamanda sağladığımız operasyonel verimlilikle de tanımlanmaktadır. Toprakçılar ailesinin bir parçası olarak, yenilikçiliğe ve liderliğe olan bağlılığımız, tekliflerimizin her noktasında açıkça görülmektedir.

EN

Toprakçılar Makina has been a leading organization in the bulgur, feed, and pellet sector since 1985, blending innovation with engineering expertise. Spanning 10,000 m² of outdoor and 4,000 m² of indoor facilities, our company is dedicated to meticulous production and unwavering quality standards. At Toprakçılar Makina, we offer more than machinery; we provide a commitment to shaping the future of bulgur production and making enduring contributions to the industry with each machine we produce. Our legacy is defined not only by our products but also by the operational efficiency we deliver. As part of the Toprakçılar family, our dedication to innovation and leadership is evident in every aspect of our offerings.



TAŞ DEĞİRMEN

STONE MILL

TEKNİK ÇİZİM VE ÖZELLİKLER

TECHNICAL DRAWING AND FEATURES

www.toprakcilarmakina.com

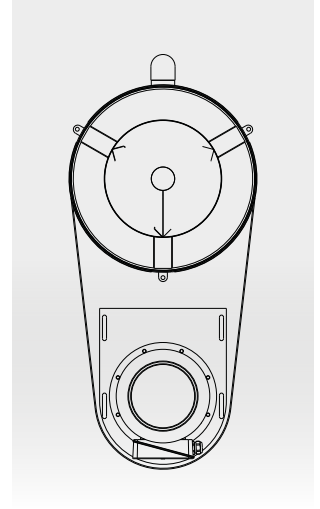
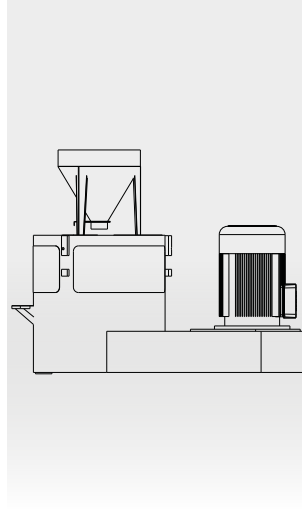
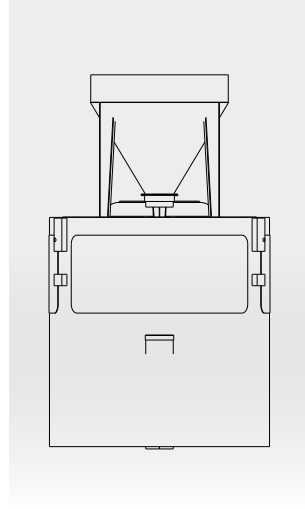
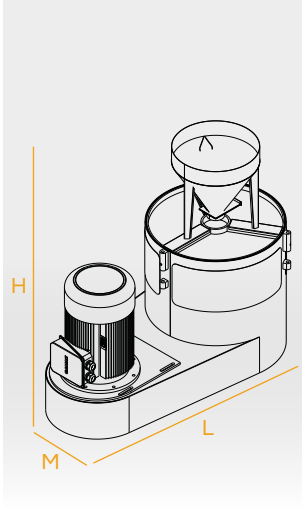

MODEL MODEL	MOTOR GÜCÜ MOTOR POWER	TAŞ ÇAPI STONE DIAMETER	KULLANIM AMACI PURPOSE OF USE	KAPASİTE CAPACITY	M-L-H
TM-TD40	11kW	ø400 ^{mm}	Bulgur	150-250Kg/h	M: 575 ^{mm} L: 1250 ^{mm} H: 1100 ^{mm}
TM-TD80	37kW	ø800 ^{mm}	Bulgur	350-550Kg/h	M: 1000 ^{mm} L: 2000 ^{mm} H: 1600 ^{mm}



TR

Toprakçılar Makina üretimi taş değirmenler daha dengeli bir ayar yapabilmek için değirmen taşı üç noktadan merkezlenmiştir. Taş değirmenler özellikle nemli (tavlı) bulgur öğütmede kullanılmaktadır. Üretilen bulgur diğer sistemlerde üretilen bulgur çeşitlerine göre daha açık sarı ve doğal bir görünüme sahiptir olmaktadır. Taşlı sistemler valsli kırma sistemlerine göre fire oranı daha düşüktür.

EN

Stone mills, designed and produced by Toprakçılar Makina, are centered at three points to provide a more balanced setting. Stone mills are used especially for grinding damp (tempered) bulgur. The bulgur produced has a lighter yellow and natural appearance compared to bulgur varieties produced in other systems. Stone systems have a lower loss rate compared to roller crushing systems.

*Değirmencilik sektöründe
profesyonel çözümler*

*Professional solutions in
milling industry*



INSTAGRAM



YOUTUBE



WEBSITE



LINKEDIN

www.toprakcilarmakina.com

ORGANİZE SANAYİ BÖLGESİ 13. SOKAK NO:3
MERKEZ / KARAMAN / TÜRKİYE