

TOPRAKÇILAR
MAKİNA SANAYİ VE TİC. LTD. ŞTİ

Since 1985

BULGUR ÜRETİM MAKİNALARI
BULGUR PRODUCTION MACHINES

SINIFLANDIRMA ELEĐİ
CLASSIFICATION SIEVE



www.toprakcilarmakina.com

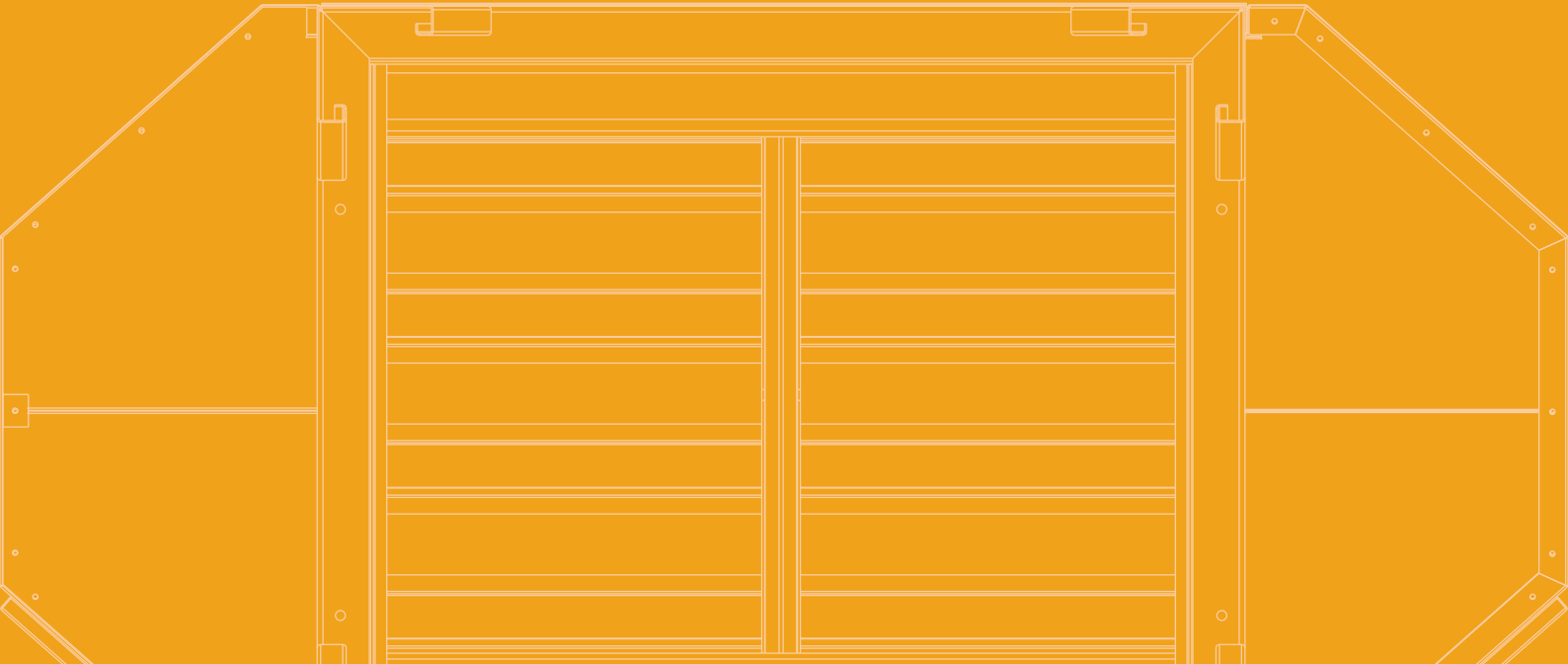

HAKKIMIZDA

ABOUT US



Toprakçılar Makina, 1985 yılından bu yana bulgur, hayvan yemi ve odun peleti sektörlerinde yenilikçi çözümleri mühendislik uzmanlığıyla birleştiren öncü bir makine ve teknoloji tedarikçisidir. 10.000 m² açık ve 4.000 m² kapalı alanı kapsayan tesislerimizde, hassas üretim ve yüksek kalite standartlarını sürdürmeye odaklanıyoruz. Sadece makineler sunmuyoruz; her makine ile bulgur üretiminin geleceğini şekillendirmeye ve sektöre kalıcı katkılar sağlamaya kararlıyız. Ünümüz, yalnızca ürünlerimizin kalitesine değil, aynı zamanda sağladığımız operasyonel verimliliğe dayanmaktadır. Toprakçılar ailesinin bir parçası olarak, yenilik ve liderlik konusundaki bağlılığımız işimizin her yönünde kendini göstermektedir.

Toprakçılar Makina is a leading machinery and technology supplier in the bulgur, animal feed, and wood pellet sectors, combining innovation with engineering expertise since 1985. Our facilities, spanning 10,000 m² outdoors and 4,000 m² indoors, are dedicated to precise production and maintaining high-quality standards. We offer more than just machinery; we are committed to shaping the future of bulgur production and making lasting contributions to the industry with each machine we deliver. Our reputation is built not only on our products but also on the operational efficiency we provide. As part of the Toprakçılar family, our dedication to innovation and leadership is evident in every aspect of our operations.



INDUSTRIAL BULGUR MACHINES

Since 1985
TOPRAKÇILAR
MAKİNA SANAYİ VE TİC. LTD. ŞTİ

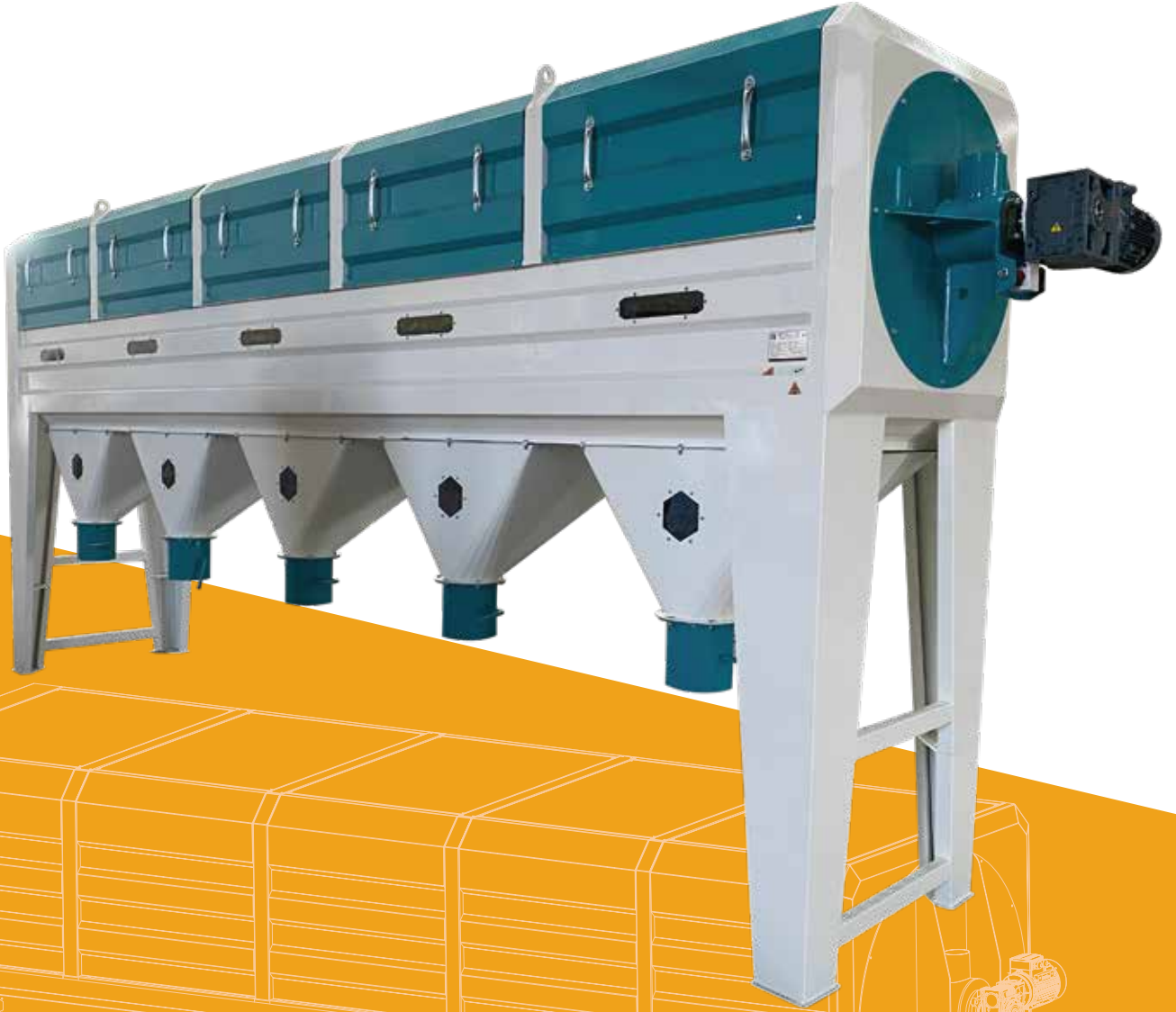

SINIFLANDIRMA ELEĐİ

CLASSIFICATION SIEVE

TEKNİK ÇİZİM VE ÖZELLİKLER

TECHNICAL DRAWING AND FEATURES

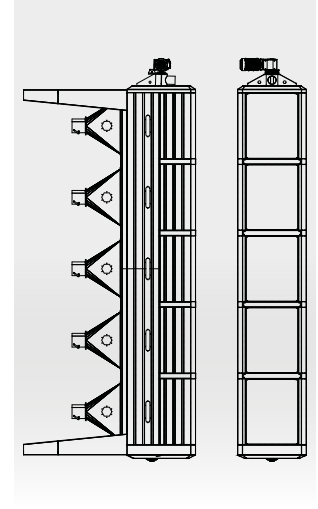
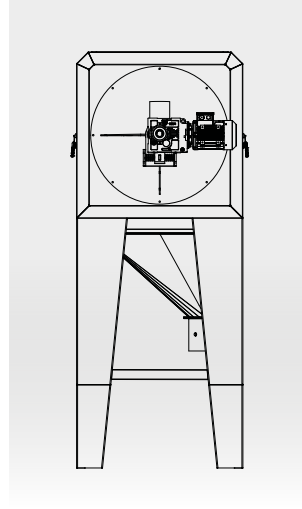
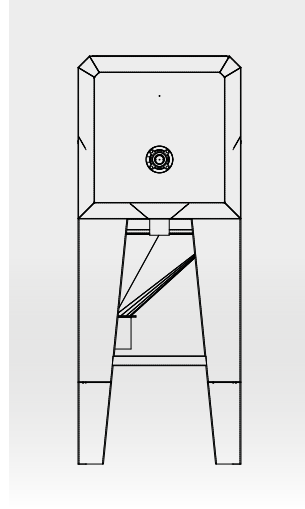
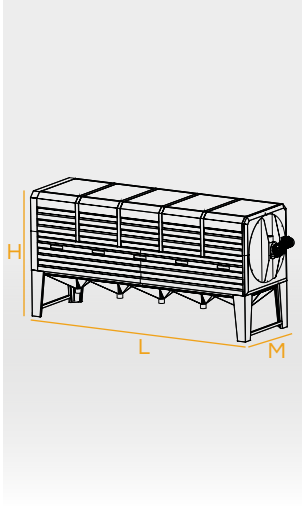

www.toprakcilarmakina.com

MODEL MODEL	MOTOR GÜCÜ MOTOR POWER	TİPİ TYPE	ELEK SAYISI SCREEN NUMBER	KAPASİTE CAPACITY	M-L-H
TM-SE10	2,2kW	Döner tip Rotary type	5	1250Kg/h	M: 1000mm L: 5400mm H: 2000mm
TM-SE25	4kW	Döner tip Rotary type	5	2500Kg/h	M: 1400mm L: 5400mm H: 2400mm
TM-SE50	5,5kW	Döner tip Rotary type	5	5000Kg/h	M: 1800mm L: 6200mm H: 2800mm

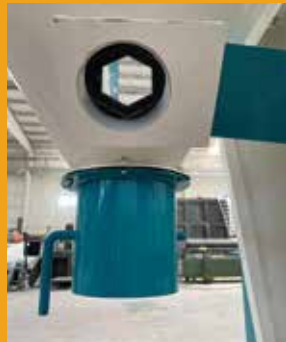

TR

Sınıflandırma eleği, bulgur tanelerini boyutlarına göre ayıran önemli bir ekipmandır. Tasarlamış olduğumuz bu elek, üretim sürecinde verimliliği artırarak bulguru sınıflara ayırarak kalitenin tandardizasyonunu sağlar.

EN

The classification sieve is an important piece of equipment that separates bulgur grains according to their size. This sieve that we designed increases efficiency in the production process and ensures standardization of quality by separating bulgur into classes.

*Değirmencilik sektöründe
profesyonel çözümler*

*Professional solutions in
milling industry*



INSTAGRAM



YOUTUBE



WEBSITE



LINKEDIN

www.toprakcilarmakina.com

ORGANİZE SANAYİ BÖLGESİ 13. SOKAK NO:3
MERKEZ / KARAMAN / TÜRKİYE