

TOPRAKÇILAR *Since 1985*
MAKİNA SANAYİ VE TİC. LTD. ŞTİ

BULGUR ÜRETİM MAKİNALARI
BULGUR PRODUCTION MACHINES

TAŞLI UN DEĞİRMENİ
STONE FLOUR MILL



www.toprakcilarmakina.com

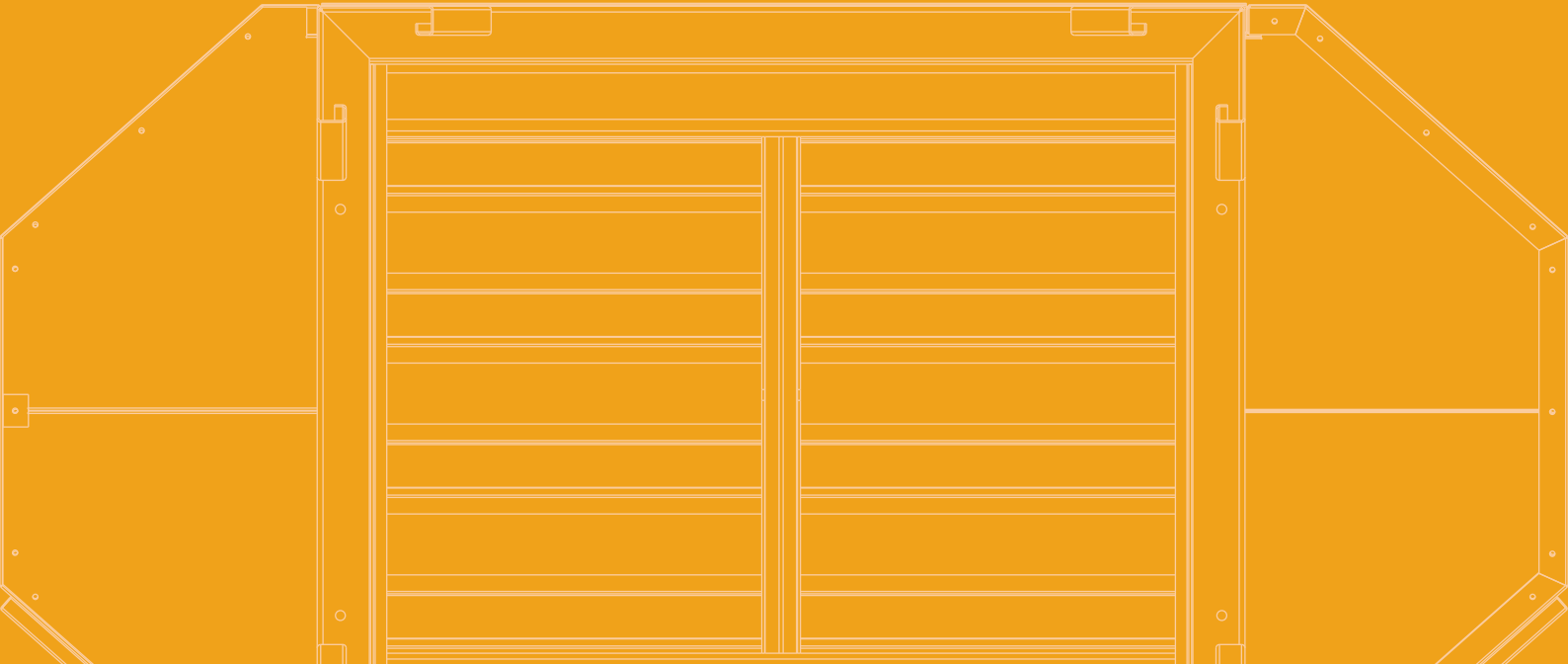

HAKKIMIZDA

ABOUT US



Toprakçılar Makina, 1985 yılından bu yana bulgur, hayvan yemi ve odun peleti sektörlerinde yenilikçi çözümleri mühendislik uzmanlığıyla birleştiren öncü bir makine ve teknoloji tedarikçisidir. 10.000 m² açık ve 4.000 m² kapalı alanı kapsayan tesislerimizde, hassas üretim ve yüksek kalite standartlarını sürdürmeye odaklanıyoruz. Sadece makineler sunmuyoruz; her makine ile bulgur üretiminin geleceğini şekillendirmeye ve sektöre kalıcı katkılar sağlamaya kararlıyız. Ünümüz, yalnızca ürünlerimizin kalitesine değil, aynı zamanda sağladığımız operasyonel verimliliğe dayanmaktadır. Toprakçılar ailesinin bir parçası olarak, yenilik ve liderlik konusundaki bağlılığımız işimizin her yönünde kendini göstermektedir.

Toprakçılar Makina is a leading machinery and technology supplier in the bulgur, animal feed, and wood pellet sectors, combining innovation with engineering expertise since 1985. Our facilities, spanning 10,000 m² outdoors and 4,000 m² indoors, are dedicated to precise production and maintaining high-quality standards. We offer more than just machinery; we are committed to shaping the future of bulgur production and making lasting contributions to the industry with each machine we deliver. Our reputation is built not only on our products but also on the operational efficiency we provide. As part of the Toprakçılar family, our dedication to innovation and leadership is evident in every aspect of our operations.





TAŞLI UN DEĞİRMENİ

STONE FLOUR MILL

TEKNİK ÇİZİM VE ÖZELLİKLER

TECHNICAL DRAWING AND FEATURES

www.toprakcilarmakina.com

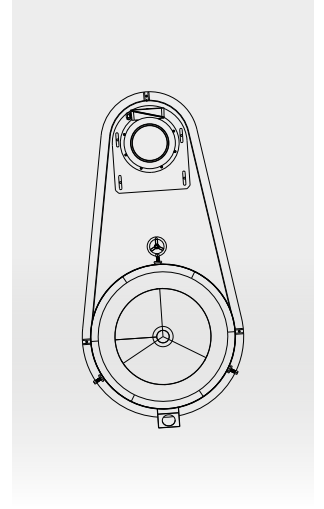
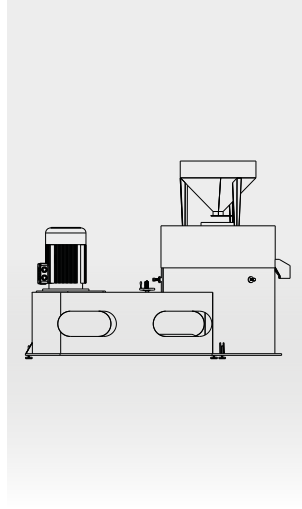
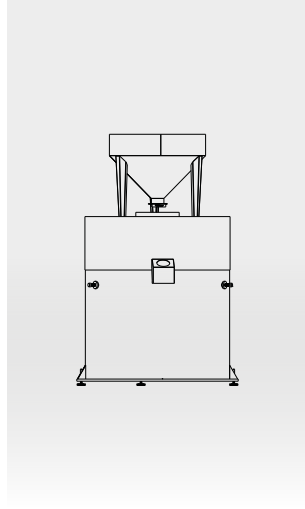
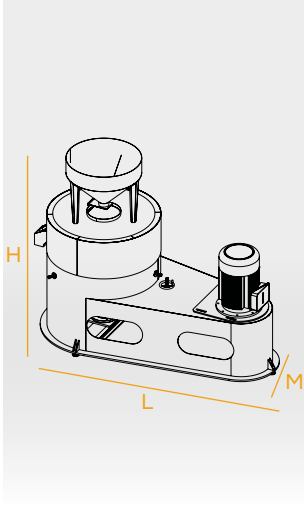

MODEL MODEL	MOTOR GÜCÜ MOTOR POWER	TAŞ ÇAPI STONE DIAMETER	KULLANIM AMACI PURPOSE OF USE	KAPASİTE CAPACITY	M-L-H
TM-UD120	37kW	ø1200mm	Un Flour	400-500Kg/h	M: 1500mm L: 3000mm H: 2300mm



TR

Taş Un Değirmeni, tahılları iki taş disk arasında öğüterek ince un üretir. Bu geleneksel öğütme yöntemi, tahılların doğal besinlerini ve lezzetini koruyan nazik bir öğütme işlemi sağlar ve bu da onu ekmekek, kek ve diğer fırıncılık ürünlerinde kullanılan yüksek kaliteli un üretmek için ideal hale getirir. Ayrıca değirmen, kepek gibi yan ürünler üretmek için buğday kabuklarını ayırır.

EN

The Stone Flour Mill produces fine flour by grinding grains between two stone discs. This traditional milling method ensures a gentle grinding process that preserves the natural nutrients and flavour of the grains, making it ideal for producing high-quality flour used in bread, cake, and other bakery products. Additionally, the mill separates the wheat hulls to produce by-products such as bran.

*Değirmencilik sektöründe
profesyonel çözümler*

*Professional solutions in
milling industry*



INSTAGRAM



YOUTUBE



WEBSITE



LINKEDIN

www.toprakcilarmakina.com

ORGANİZE SANAYİ BÖLGESİ 13. SOKAK NO:3
MERKEZ / KARAMAN / TÜRKİYE