

**TOPRAKÇILAR**  
MAKİNA SANAYİ VE TİC. LTD. ŞTİ

Since 1985

**YEM PELET MAKİNELERİ**  
**FEED PELLET MACHINES**



[www.toprakcilarmakina.com](http://www.toprakcilarmakina.com)

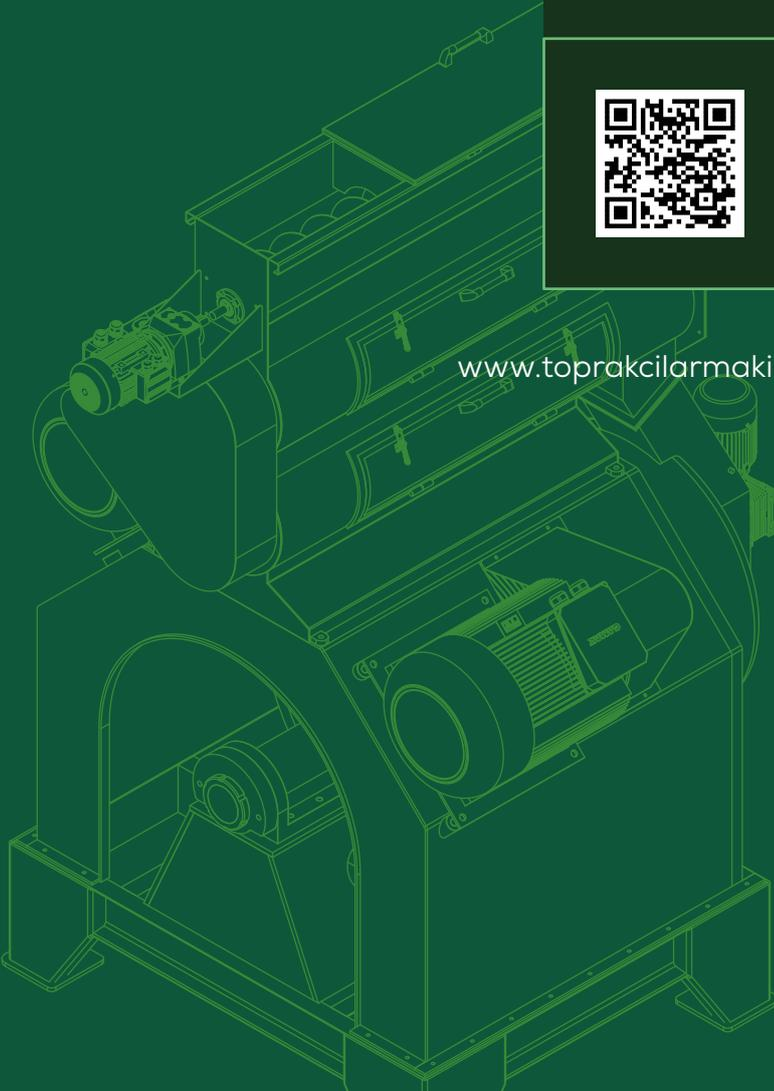

## TR

Peletlerinin yapısında bulunan ana bileşenler:

**Karbonhidratlar:** Yem peletlerinde en yaygın bulunan bileşenlerden biridir. Genellikle mısır, buğday, arpa gibi tahıllardan elde edilen nişasta formunda bulunur. Karbonhidratlar, hayvanlar için hızlı bir enerji kaynağı sağlar. **Proteinler:** Hayvansal ve bitkisel kaynaklardan gelen proteinler, yem peletlerinin önemli bir bileşenidir. Soya unu, balık unu, et ve kemik unu gibi kaynaklardan elde edilen proteinler, hayvanların büyüme ve gelişme süreçlerinde gereklidir.

**Yağlar ve Yağ Asitleri:** Yem peletlerine enerji yoğunluğu kazandıran yağlar, aynı zamanda hayvanların deri sağlığı ve üreme fonksiyonları için de önemlidir. Bitkisel yağlar (soya yağı, ayçiçek yağı) ve hayvansal yağlar bu gruba girer.

**Lifler:** Yem peletlerinde bulunan lifler, sindirim sisteminin sağlıklı çalışmasını destekler. Yonca, saman ve kepek gibi yüksek lifli bitkisel materyaller bu bileşeni sağlar.

**Vitaminler ve Mineraller:** Hayvanların genel sağlığı ve bağışıklık sisteminin desteklenmesi için yem peletlerine çeşitli vitaminler (A, D, E, K) ve mineraller (kalsiyum, fosfor, magnezyum) eklenir.

Bu bileşenlerin kombinasyonu, yem peletlerinin besleyici değerini artırır ve hayvanların sağlıklı bir şekilde büyüyüp gelişmelerini sağlar.

## EN

The main components found in the structure of the pellets are:

**Carbohydrates:** One of the most common components in feed pellets. They are typically found in the form of starch derived from grains such as corn, wheat, and barley. Carbohydrates provide a quick energy source for animals.

**Proteins:** Proteins from animal and plant sources are the important components of feed pellets. Proteins derived from sources like soybean meal, fish meal, meat and bone meal are essential for the growth and development of animals.

**Fats and Fatty Acids:** Fats, which add energy density to the feed pellets, are also important for the skin health and reproductive functions of animals. Vegetable oils (soybean oil, sunflower oil) and animal fats fall into this category.

**Fibers:** The fibers present in feed pellets support the healthy functioning of the digestive system. High-fiber plant materials such as alfalfa, straw, and bran provide this component.

**Vitamins and Minerals:** Various vitamins (A, D, E, K) and minerals (calcium, phosphorus, magnesium) are added to feed pellets to support the general health and immune system of animals.

The combination of these components increases the nutritional value of feed pellets and ensures the healthy growth and development of animals.



# HAKKIMIZDA

## ABOUT US



### TR

Toprakçılar Makina, 1985'ten beri bulgur, yem ve pelet sektöründe öncü bir kuruluş olup, yenilikçiliği mühendislik uzmanlığıyla harmanlamaktadır. 10.000 m<sup>2</sup> açık ve 4.000 m<sup>2</sup> kapalı alana yayılmış olan firmamız, titiz üretime ve sarsılmaz kalite standartlarına kendini adanmıştır. Toprakçılar Makina olarak, makinelerden daha fazlasını sunuyoruz; ürettiğimiz her makineyle bulgur üretiminin geleceğini şekillendirme ve sektöre kalıcı katkılarda bulunma taahhüdünde bulunuyoruz. Mirasımız yalnızca ürünlerimizle değil, aynı zamanda sağladığımız operasyonel verimlilikle de tanımlanmaktadır. Toprakçılar ailesinin bir parçası olarak, yenilikçiliğe ve liderliğe olan bağlılığımız, tekliflerimizin her noktasında açıkça görülmektedir.

### EN

Toprakçılar Makina has been a leading organization in the bulgur, feed, and pellet sector since 1985, blending innovation with engineering expertise. Spanning 10,000 m<sup>2</sup> of outdoor and 4,000 m<sup>2</sup> of indoor facilities, our company is dedicated to meticulous production and unwavering quality standards. At Toprakçılar Makina, we offer more than machinery; we provide a commitment to shaping the future of bulgur production and making enduring contributions to the industry with each machine we produce. Our legacy is defined not only by our products but also by the operational efficiency we deliver. As part of the Toprakçılar family, our dedication to innovation and leadership is evident in every aspect of our offerings.

# ÜRETİMDEN BİZ

FROM PRODUCTION, WE





**PELET YEM  
ÜRETİM TESİSİ**



**BULGUR ÜRETİM  
TESİSİ**



**AHŞAP PELET  
ÜRETİM TESİSİ**



**CEVİZ ÜRETİM  
TESİSİ**



**BULUNDUĞUMUZ SEKTÖRLER / SECTORS SERVED**

# AHŞAP PELET MAKİNALARI

## WOOD PELLET MACHINES

### TEMEL UNSURLAR

#### BASIC ELEMENTS

#### TR

Yem pelet makinaları, çeşitli tarım hayvanları için yem üretiminde kullanılan kritik araçlardır. Bu makineler, çeşitli yem hammaddelerini öğütür, karıştırarak ve pelete dönüştürerek homojen yem peletleri üretirler. Yem pelet makinalarının temel unsurları:

**Öğütücü:** Yem hammaddelerini küçük parçalara öğüten bu bölüm, malzemelerin daha homojen bir karışım oluşturmasını sağlar.

**Mikser:** Karışımı yapmak için farklı hammaddeleri birleştirir. Bu aşama, yemin besin değerini optimize etmek için önemlidir.

**Peletleme Ünitesi:** Hazırlanan karışımı pelete dönüştüren bu ünite, peletlerin istenen boyut ve şekilde üretilmesini sağlar.

**Soğutma ve Kurutma:** Yeni üretilen peletlerin nemini azaltır ve dayanıklılığını artırır.

**Eleme ve Paketleme:** Peletlerin kalitesini kontrol etmek ve uygun paketlemeyi sağlamak için bu adımlar uygulanır.

#### EN

Feed pellet machines are critical tools used in the production of feed for various agricultural animals. These machines produce homogeneous feed pellets by grinding, mixing and converting various feed raw materials into pellets. Here are the key elements of feed pellet production line:

**Grinder:** This section, which grinds the feed raw materials into small pieces, enables the materials to form a more homogeneous mixture.

**Mixer:** It combines different raw materials to make the mixture. This stage is important to optimize the nutritional value of the feed.

**Pelletizing Unit:** This unit, which transforms the prepared mixture into pellets, ensures that the pellets are produced in the desired size and shape.

**Cooling and Drying:** It reduces the moisture of the newly produced pellets and increases their durability.

**Sieving and Packaging:** These steps are applied to control the quality of the pellets and ensure proper packaging.



## İNNOVASYON VE KALİTE

### INNOVATION AND QUALITY

#### TR

Yem pelet makinaları üretimi, sürekli olarak teknoloji ve mühendislikle ileri gitmektedir. Dijital kontroller, otomasyon ve veri analitiği, bu makinelerin verimliliğini artırırken enerji tüketimini azaltmaya yardımcı olur. Ayrıca, malzemelerin hassas bir şekilde karıştırılması ve peletlenmesini sağlayarak yemin kalitesini yükseltir.

Kalite kontrolü, yem pelet makinaları üretiminde kritik bir rol oynar. Bu makinelerin dayanıklılığı, uzun ömürlülüğü ve düşük bakım ihtiyacı, çiftçilerin ve yem üreticilerinin güvenilirlik arayışlarını karşılamak için önemlidir. Ayrıca, çevresel sürdürülebilirliği destekleyen enerji verimliliği ve atık yönetim gibi faktörlere de dikkat edilir.

#### EN

The production of feed pellet machines is constantly moving forward with technology and engineering. Digital controls, automation and data analytics help reduce energy consumption while increasing the efficiency of these machines. It also improves the quality of the feed by ensuring that the ingredients are mixed and pelleted precisely.

Quality control plays a critical role in the production of feed pellet machines. The durability, longevity and low maintenance of these machines are important to meet the reliability demands of farmers and feed manufacturers. In addition, consideration is given to factors such as energy efficiency and waste management that support environmental sustainability.

**TÖPRAKÇILAR**  
MAKİNA SANAYİ VE TİC. LTD. ŞTİ

Since 1985

*innovation and quality*



AHŞAP PELET MAKİNALARI / WOOD PELLET MACHINES



**YEM  
PELET PRESİ**

FEED PELLET PRESS

# TEKNİK ÇİZİM VE ÖZELLİKLER

## TECHNICAL DRAWING AND FEATURES

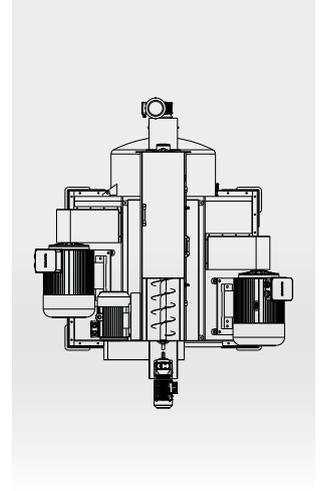
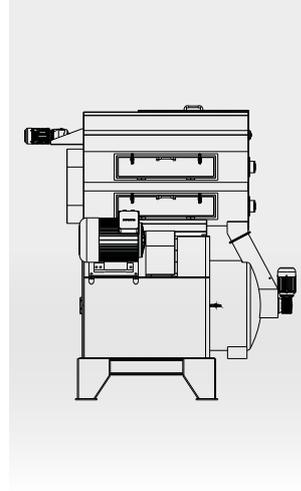
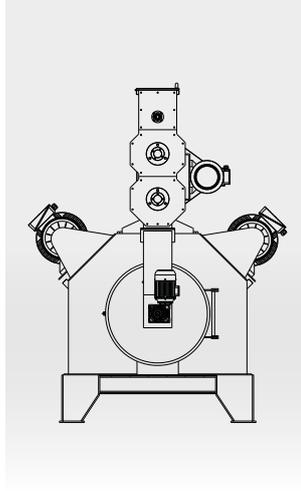
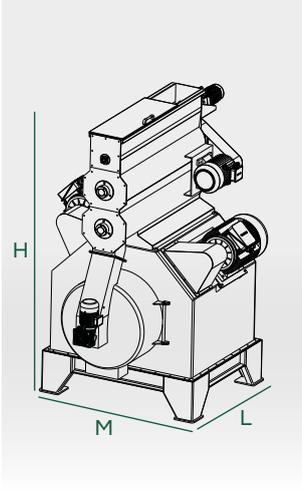

MODEL MODEL	MOTOR GÜCÜ MOTOR POWER	KONDİSYONER GÜCÜ CONDITIONER POWER	DİSK ÇAPI DISC DIAMETER	KAPASİTE CAPACITY	M-L-H
TM-YPP	2x 110kW	18,5kWx 2,2kW	600 <sup>mm</sup>	15000Kg/h	M: 2700 <sup>mm</sup> L: 2500 <sup>mm</sup> H: 3500 <sup>mm</sup>



### TR

Pelet presleri, toz haline getirilmiş maddenin rulolar ile disk üzerinde mekanik olarak sıkıştırılıp, disk üzerindeki delik çapına göre farklı boyutlarda pelet üretilmesini sağlayan makinalardır. Hayvan yemi sektöründe kullanılan bu makinanın ise yem kalitesine büyük etkisi vardır. Pelet presi içerisine buharla birlikte gönderilen toz hammadde mekanik sıkıştırmanın da etkisiyle içerisindeki sindirimi zor olan nişasta jelatinize olur ve besin değeri artar.

### EN

Pellet presses are machines that mechanically compress the powdered material on the disc with rollers and produce pellets of different sizes according to the hole diameter on the disc. This machine, used in the animal feed sector, has a great effect on feed quality. The starch in the powdered raw material sent into the pellet press with steam is gelatinized by the mechanical compression, which is difficult to digest, thus increasing nutritional value of the feed.

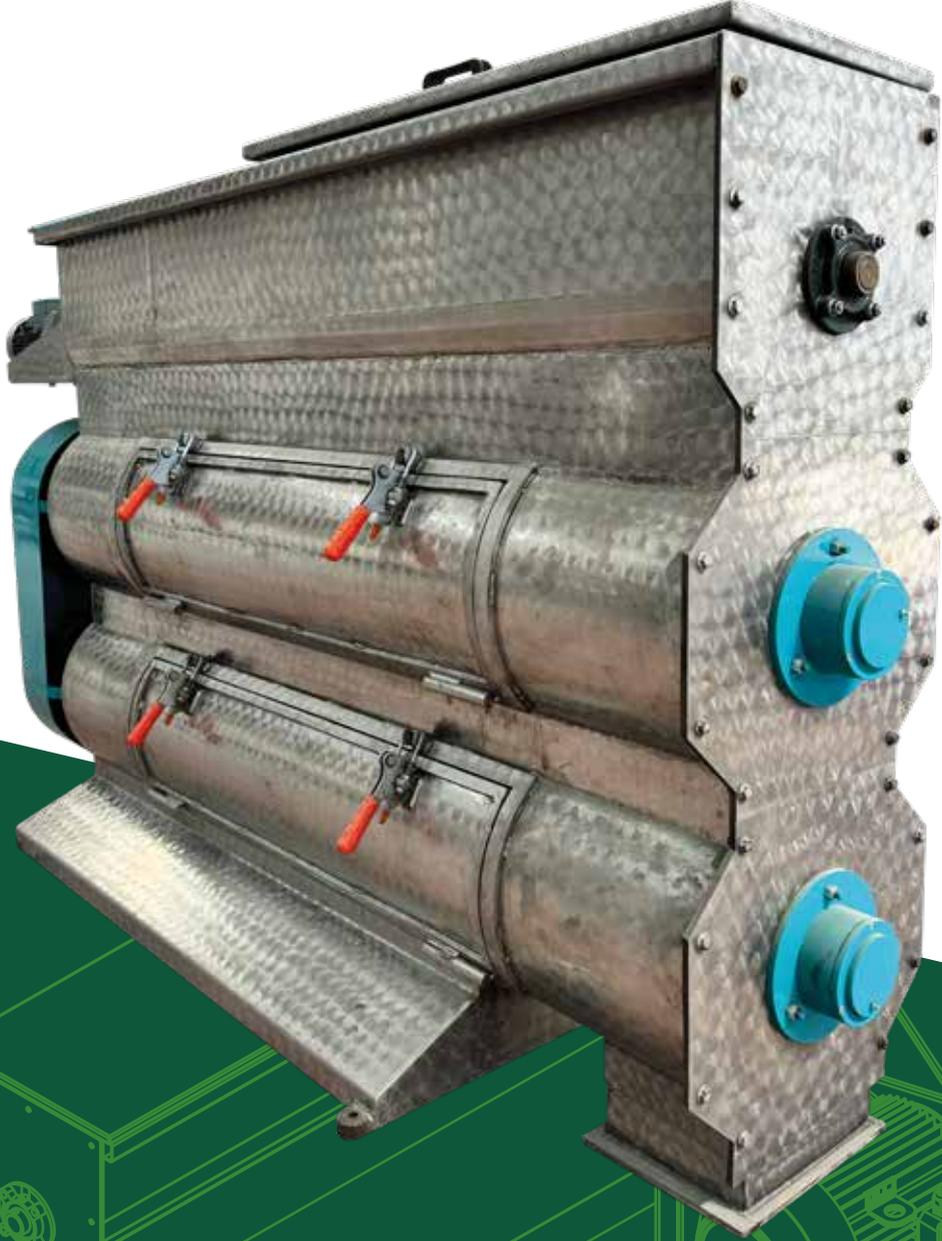

**KONDİSYONER**

CONDITIONER

# TEKNİK ÇİZİM VE ÖZELLİKLER

## TECHNICAL DRAWING AND FEATURES

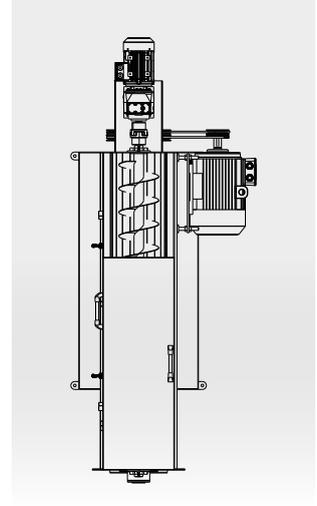
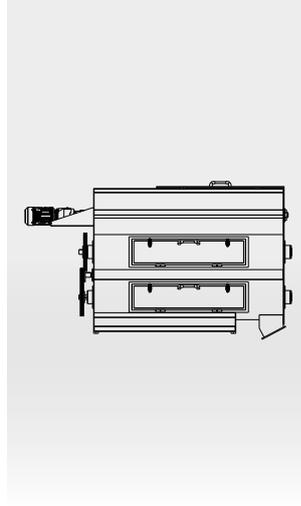
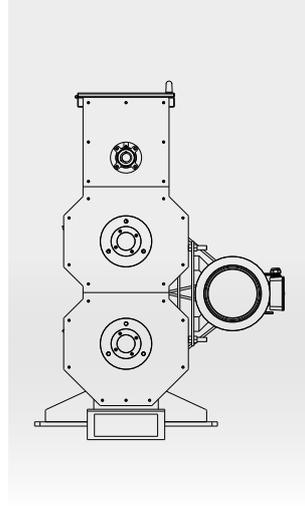
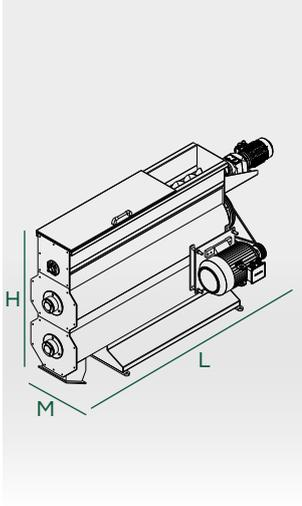

MODEL MODEL	MOTOR GÜCÜ MOTOR POWER	BESLEME MOTORU FEEDING MOTOR	KAT SAYISI NUMBER OF LAYERS	M-L-H
<b>TM-PPK18</b>	18.5kW	2,2kW	2	<b>M: 1150<sup>mm</sup></b> <b>L: 2200<sup>mm</sup></b> <b>H: 1200<sup>mm</sup></b>
<b>TM-PPK22</b>	22kW	3kW	3	<b>M: 1150<sup>mm</sup></b> <b>L: 2200<sup>mm</sup></b> <b>H: 1560<sup>mm</sup></b>



### TR

Kondisyoner, buhar, su veya diğer sıvıları yeme ekleyerek karışımın sıcaklığını ve nem seviyesini artırır, bu da peletleme işlemi için ideal koşulları sağlar. Bu süreç, yem maddelerinin birbirine daha iyi yapışmasını ve peletlerin dayanıklılığını artırır. Yemlerin sindirilebilirliğini ve besin değerini artırarak hayvanların daha verimli bir şekilde beslenmesini sağlar. Kondisyonerler, yem üretim hattının verimliliğini optimize eder ve nihai ürünün kalitesini önemli ölçüde yükseltir.

### EN

A conditioner adds steam, water, or other liquids to the feed mixture, increasing its temperature and moisture levels, creating ideal conditions for the pelleting process. This process enhances the binding of feed materials and improves the durability of the pellets. It also increases the digestibility and nutritional value of the feed, enabling animals to be fed more efficiently. Conditioners optimize the efficiency of the feed production line and significantly enhance the quality of the final product.

Since 1985  
**TOPRAKÇILAR**  
MAKİNA SANAYİ VE TİC. LTD. ŞTİ



# YEM ÇEKİÇLİ DEĞİRMEN

FEED HAMMER MILL

# TEKNİK ÇİZİM VE ÖZELLİKLER

## TECHNICAL DRAWING AND FEATURES

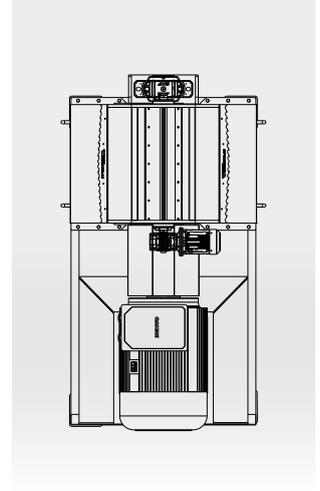
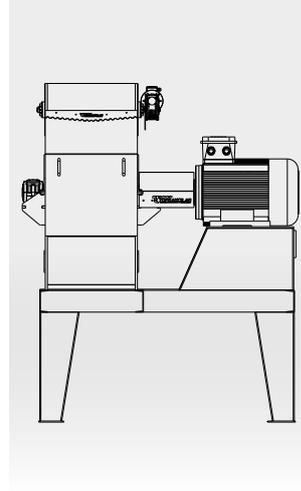
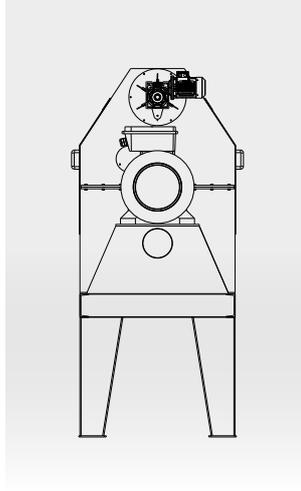
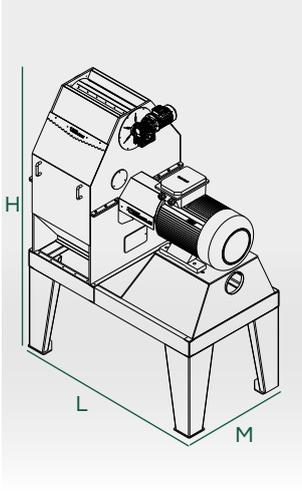

MODEL MODEL	MOTOR GÜCÜ MOTOR POWER	BESLEME TİPİ FEEDING TYPE	BESLEME MOTORU FEEDING MOTOR	KAPASİTE CAPACITY	M-L-H
<b>TM-YCD7</b>	37kW	HELEZON SCREW CONVEYOR	1,1kW	10000Kg/h	<b>M: 1300mm</b> <b>L: 2000mm</b> <b>H: 3200mm</b>
<b>TM-YCD15</b>	75kW	DÖNER BESLEYİCİ ROTARY FEEDER	1,5kW	15000Kg/h	<b>M: 1300mm</b> <b>L: 2400mm</b> <b>H: 4000mm</b>
<b>TM-YCD20</b>	132kW	DÖNER BESLEYİCİ ROTARY FEEDER	2,2kW	20000Kg/h	<b>M: 1300mm</b> <b>L: 2400mm</b> <b>H: 4000mm</b>
<b>TM-YCD30</b>	132kW	DÖNER BESLEYİCİ ROTARY FEEDER	2,2kW	30000Kg/h	<b>M: 1300mm</b> <b>L: 2400mm</b> <b>H: 4000mm</b>



### TR

Çekiçli değirmen, yem ve ahşap pelet fabrikalarında öğütme işlemini gerçekleştiren makinedir. Çekiçler değirmen miline diskler aracılığı ile bağlıdır ve es merkezli olarak çalışır. Çekiçli değirmen içerisine giren taneli hububat veya odun parçaları belli devirde dönen çekiçlerin darbesi ile kırılır ve küçük parçalara ayrılır.

### EN

Hammer mill is a machine that performs the grinding process in feed and wood pellet factories. Hammers are connected to the mill shaft via discs and operate concentrically. The granular products or wood pieces entering the hammer mill are broken into small pieces by the impact of the hammers rotating at a certain speed.



**KARIŐTIRICI**

MIXER

# TEKNİK ÇİZİM VE ÖZELLİKLER

## TECHNICAL DRAWING AND FEATURES

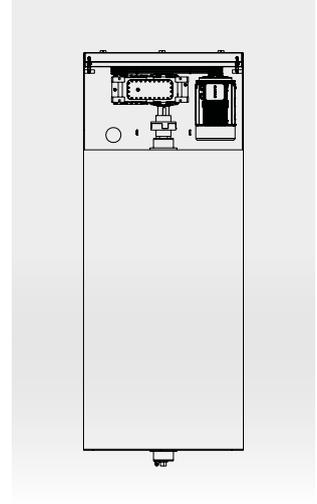
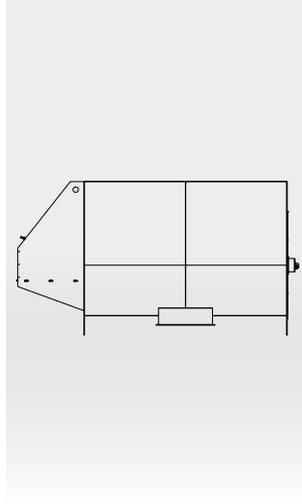
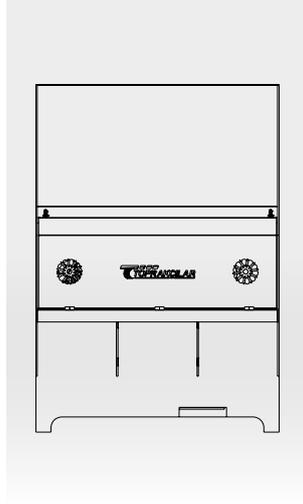
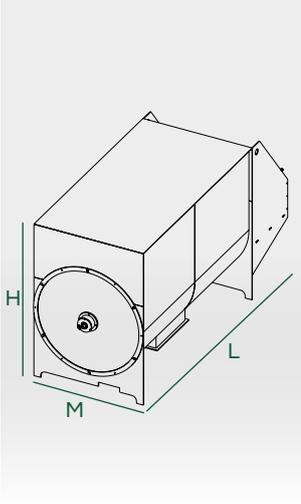

MODEL MODEL	MOTOR GÜCÜ MOTOR POWER	KARIŞTIRICI ÇAPI MIXER DIAMETER	DEVİR REVOLUTION	KAPASİTE CAPACITY	M-L-H
<b>TM-PK5</b>	18,5kW	1200 <sup>mm</sup>	46RPM	5m <sup>3</sup>	<b>M: 1500<sup>mm</sup></b> <b>L: 3500<sup>mm</sup></b> <b>H: 1800<sup>mm</sup></b>
<b>TM-PK8</b>	22kW	1300 <sup>mm</sup>	46RPM	8m <sup>3</sup>	<b>M: 1500<sup>mm</sup></b> <b>L: 4000<sup>mm</sup></b> <b>H: 2300<sup>mm</sup></b>
<b>TM-PK10</b>	30kW	1400 <sup>mm</sup>	49RPM	10m <sup>3</sup>	<b>M: 1500<sup>mm</sup></b> <b>L: 4000<sup>mm</sup></b> <b>H: 2500<sup>mm</sup></b>



### TR

Karıştırıcı, hammaddeyi homojen bir karışım haline getirmek için kullanılır. Hammaddelerin düzgün bir şekilde karışmasını sağlar. Karıştırma işlemi, peletlerin tutarlı bir kaliteye sahip olmasını ve düzgün bir şekilde şekillendirilmesini sağlar. Yüksek verimlilik sunarak üretim sürecinin hızlanmasına yardımcı olur. Karıştırıcılar enerji tasarrufu sağlayan ve bakımı kolay tasarıma sahiptir.

### EN

A mixer is used to create a homogeneous mixture of raw materials. It ensures that the raw materials are thoroughly mixed. The mixing process helps maintain consistent quality and proper shaping of the pellets. By offering high efficiency, it aids in speeding up the production process. Mixers are designed to be energy-efficient and easy to maintain.



## DİKEY KARIŞTIRICI

VERTICAL MIXER

# TEKNİK ÇİZİM VE ÖZELLİKLER

## TECHNICAL DRAWING AND FEATURES

www.toprakcilarmakina.com

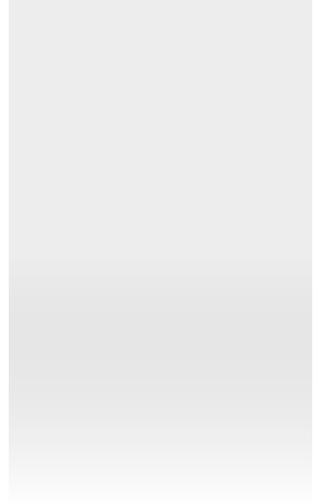
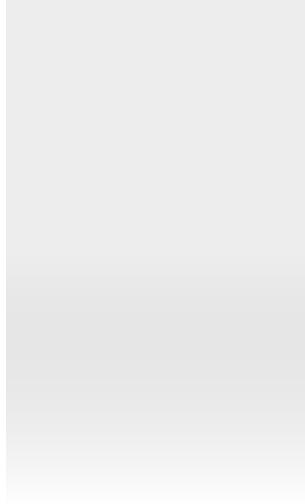
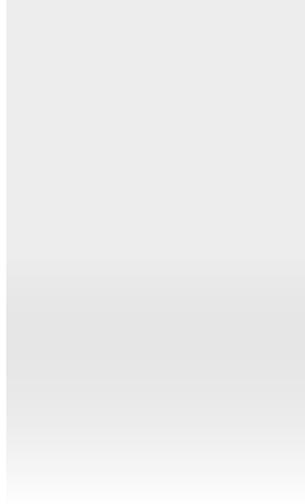
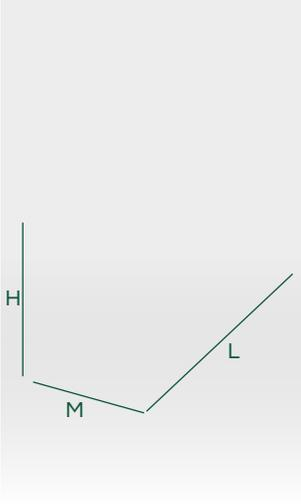

MODEL MODEL	MOTOR GÜCÜ MOTOR POWER			KAPASİTE CAPACITY	M-L-H
TM-DK					M: 1500 <sup>mm</sup> L: 3500 <sup>mm</sup> H: 1800 <sup>mm</sup>
TM-DK					M: 1500 <sup>mm</sup> L: 4000 <sup>mm</sup> H: 2300 <sup>mm</sup>
TM-DK					M: 1500 <sup>mm</sup> L: 4000 <sup>mm</sup> H: 2500 <sup>mm</sup>



### TR

Karıştırıcı, hammaddeyi homojen bir karışım haline getirmek için kullanılır. Hammaddelerin düzgün bir şekilde karışmasını sağlar. Karıştırma işlemi, peletlerin tutarlı bir kaliteye sahip olmasını ve düzgün bir şekilde şekillendirilmesini sağlar. Yüksek verimlilik sunarak üretim sürecinin hızlanmasına yardımcı olur. Karıştırıcılar enerji tasarrufu sağlayan ve bakımı kolay tasarıma sahiptir.

### EN

A mixer is used to create a homogeneous mixture of raw materials. It ensures that the raw materials are thoroughly mixed. The mixing process helps maintain consistent quality and proper shaping of the pellets. By offering high efficiency, it aids in speeding up the production process. Mixers are designed to be energy-efficient and easy to maintain.



**DOZAJ KANTARI**

DOSAGE SCALE

# TEKNİK ÇİZİM VE ÖZELLİKLER

## TECHNICAL DRAWING AND FEATURES

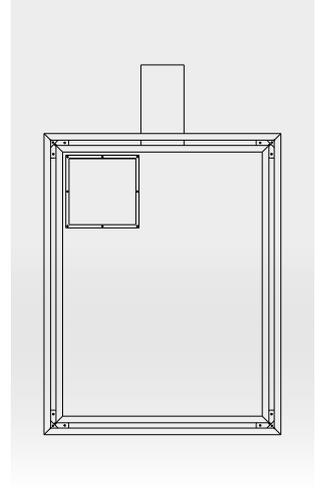
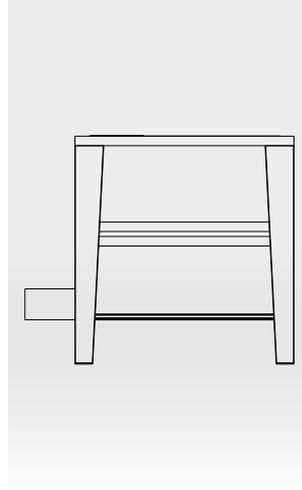
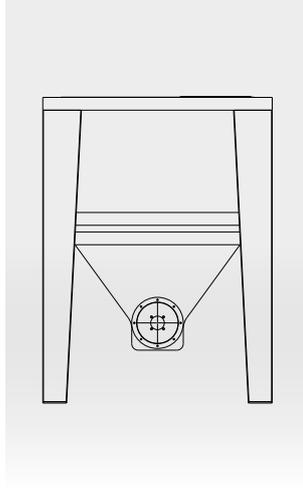
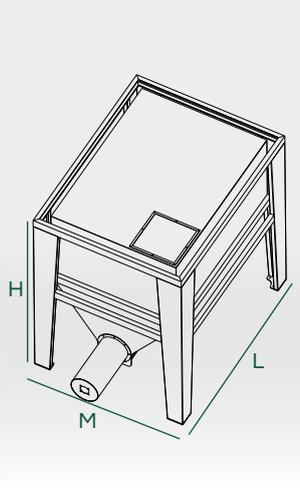

www.toprakcilarmakina.com

MODEL MODEL	KANTAR ÇIKIŞI WEIGHBRIDGE EXIT	LOADCELL ADET LOADCELL QUANTITY	KAPASİTE CAPACITY	M-L-H
<b>TM-YDK5</b>	400 <sup>mm</sup> X400 <sup>mm</sup>	3	5m <sup>2</sup>	<b>M: 1800<sup>mm</sup></b> <b>L: 2300<sup>mm</sup></b> <b>H: 2400<sup>mm</sup></b>
<b>TM-YDK8</b>	600 <sup>mm</sup> X400 <sup>mm</sup>	4	8m <sup>2</sup>	<b>M: 1800<sup>mm</sup></b> <b>L: 2300<sup>mm</sup></b> <b>H: 3400<sup>mm</sup></b>
<b>TM-YDK10</b>	800 <sup>mm</sup> X400 <sup>mm</sup>	4	10m <sup>2</sup>	<b>M: 1800<sup>mm</sup></b> <b>L: 2800<sup>mm</sup></b> <b>H: 3400<sup>mm</sup></b>



### TR

Yem hazırlama işleminde uygun dozajda yem hayvancılık sektörü için oldukça önemlidir. Dozaj kantarı, özellikle hayvancılık sektöründe yemin besin miktarına uygun olarak dozajlanması için kullanılır. Dozaj kantarı hassas tartım özelliğine sahip olup, tartımdan sonra bunkere hızlı boşaltım sağlayan pnömatik vagon sürgüye sahiptir.

### EN

In the feed preparation process, adding ingredients in the appropriate dosage is very important for the livestock. The dosage scale is used especially in the livestock sector to dose the feed in accordance with the amount of food. The dosage scale has a sensitive weighing feature and has a pneumatic wagon slide that provides rapid discharge to the bunker after weighing.



## PELET SOĞUTUCU

PELLET COOLER

# TEKNİK ÇİZİM VE ÖZELLİKLER

## TECHNICAL DRAWING AND FEATURES

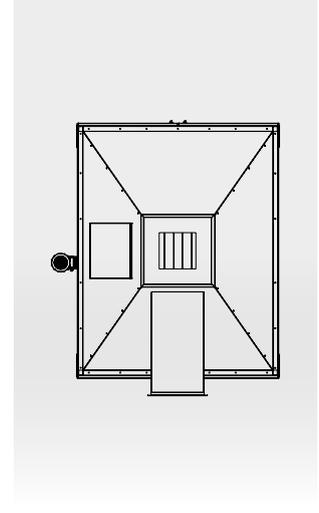
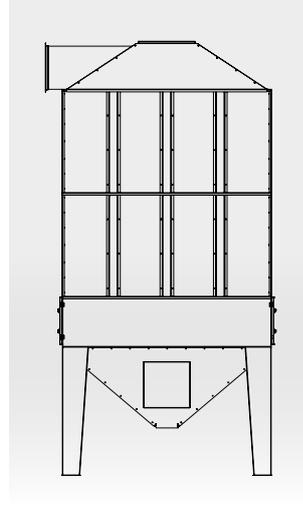
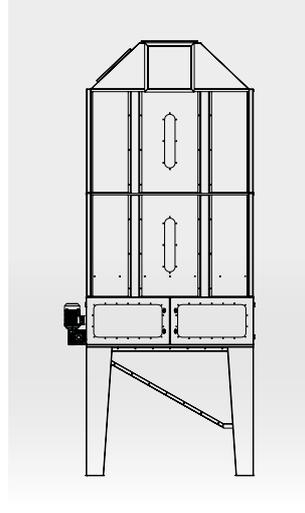
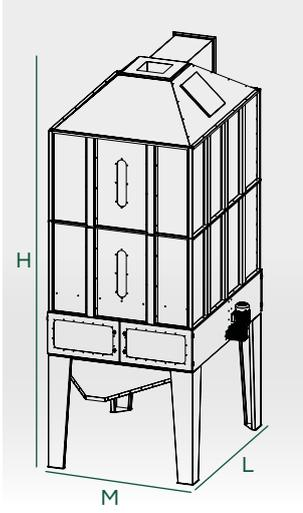

www.toprakcilarmakina.com

MODEL MODEL	MOTOR GÜCÜ MOTOR POWER	PASA ADEDİ NUMBER OF PASSES	KAPASİTE CAPACITY	M-L-H
<b>TM-PSK20</b>	1,1kW	2	5000Kg/h	<b>M: 1900<sup>mm</sup></b> <b>L: 2450<sup>mm</sup></b> <b>H: 5000<sup>mm</sup></b>
<b>TM-PSK30</b>	1,5kW	3	10000Kg/h	<b>M: 1900<sup>mm</sup></b> <b>L: 2450<sup>mm</sup></b> <b>H: 6200<sup>mm</sup></b>



### TR

Pelet soğutucu, pelet üretim sürecinde sıcak peletlerin hızlı ve verimli bir şekilde soğutulması için kullanılır. Peletler, üretim sırasında yüksek sıcaklıklara ulaşır ve bu sıcaklıkların düşürülmesi gereklidir. Soğutma işlemi, peletlerin kalitesini artırır ve depolama sırasında bozulmalarını önler. Peletlerin homojen bir şekilde soğutulmasını sağlar, böylece ürün kalitesi tutarlı olur. Ayrıca, soğutma süresi kısa tutulur, bu da üretim verimliliğini artırır.

### EN

A pellet cooler is used to quickly and efficiently cool hot pellets in the pellet production process. During production, pellets reach high temperatures and need to be cooled. The cooling process improves the quality of the pellets and prevents spoilage during storage. It ensures that the pellets are cooled uniformly, resulting in consistent product quality. Additionally, the cooling time is kept short, which increases production efficiency.



## VİBRO PELET ELEK

VIBRO PELLET SIEVE

# TEKNİK ÇİZİM VE ÖZELLİKLER

## TECHNICAL DRAWING AND FEATURES

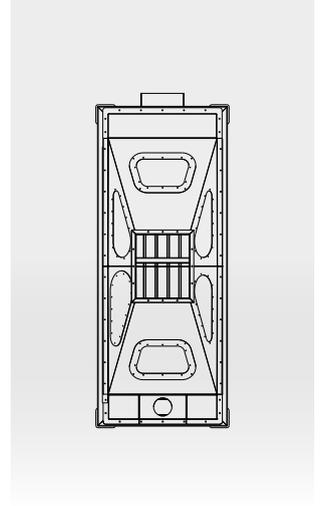
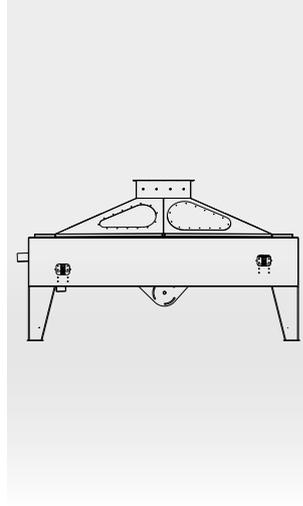
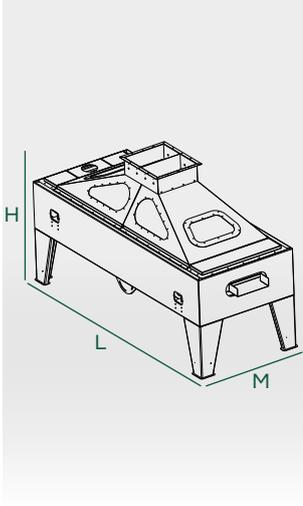

MODEL MODEL	MOTOR GÜCÜ MOTOR POWER	ELEK ÇAPI SIEVE DIAMETER	KAPASİTE CAPACITY	M-L-H
<b>TM-PE25</b>	2x0,94kW	4 <sup>mm</sup>	2500Kg/h	<b>M: 1200<sup>mm</sup></b> <b>L: 3000<sup>mm</sup></b> <b>H: 1800<sup>mm</sup></b>
<b>TM-PE50</b>	2x1,2kW	4 <sup>mm</sup>	5000Kg/h	<b>M: 1200<sup>mm</sup></b> <b>L: 4000<sup>mm</sup></b> <b>H: 1800<sup>mm</sup></b>



### TR

Pelet eleği, tozu ve küçük veya kırık peletleri ayırmak için kullanılır ve yalnızca istenen boyuttaki peletlerin tutulmasını sağlar. Bu eleme süreci, nihai ürünün kalitesini ve tekdüzeliğini artırır. Kullanılan eleme sistemine bağlı olarak, farklı boyutlardaki peletler sınıflandırılır ve üretim hattında yeniden işlenmek üzere yeniden dolaştırılır, böylece pelet üretiminde genel üretim verimliliği ve ürün kalitesi iyileştirilir.

### EN

Pellet screen is utilized to separate dust and undersized or broken pellets, ensuring that only pellets of the desired size are retained. This screening process enhances the quality and uniformity of the final product. Depending on the screening system employed, pellets of varying sizes are classified and recirculated for reprocessing in the production line, thereby improving overall production efficiency and product quality in pellet manufacturing.



## PILOT PELET ELEĞİ

PILOT PELLET SIEVE

# TEKNİK ÇİZİM VE ÖZELLİKLER

## TECHNICAL DRAWING AND FEATURES

www.toprakcilarmakina.com

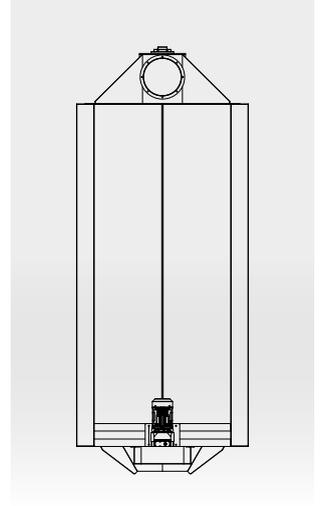
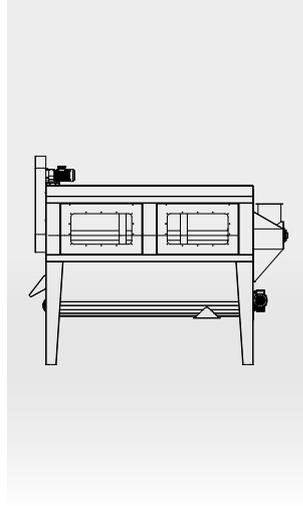
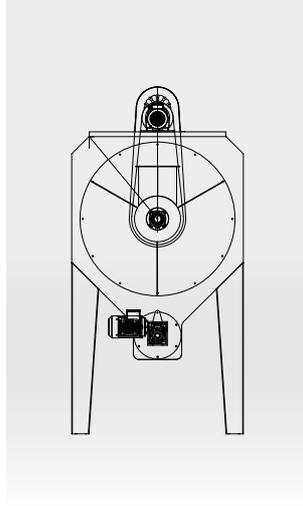
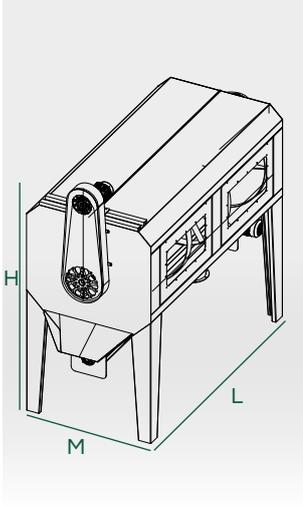

MODEL MODEL	MOTOR GÜCÜ MOTOR POWER	HELEZON ÇAPI SCREW DIAMETER	HELEZON MOTORU SCREW MOTOR	KAPASİTE CAPACITY	M-L-H
<b>TM-PPE25</b>	3kW	300Ø	2,2kW	2500Kg/h	<b>M: 1500mm</b> <b>L: 3650mm</b> <b>H: 2600mm</b>
<b>TM-PPE50</b>	5,5kW	300Ø	2,2kW	5000Kg/h	<b>M: 2100mm</b> <b>L: 5500mm</b> <b>H: 4600mm</b>



### TR

Pilot pelet eleği, pelet üretim sürecinde peletlerin toz ve küçük parçacıklardan arındırılması için kullanılan bir makinedir. Bu eleme işlemi, peletlerin kalitesini artırarak daha homojen ve kullanıma hazır bir ürün elde edilmesini sağlar. Elek, farklı boyutlardaki elek gözleriyle donatılmış olup, peletlerin boyutuna göre hassas bir ayırıştırma işlemi gerçekleştirir. Bu makineler, pelet üretim hattının verimliliğini artırır ve son ürünün kalitesini optimize eder.

### EN

A pellet sieve is a machine used in the pellet production process to remove dust and small particles from the pellets. This screening process enhances the quality of the pellets, resulting in a more homogeneous and ready-to-use product. The sieve is equipped with screens of various sizes, allowing for precise separation of pellets based on their size. These machines increase the efficiency of the pellet production line and optimize the quality of the final product.



**HAVA FANI**

**AIR FAN**

# TEKNİK ÇİZİM VE ÖZELLİKLER

## TECHNICAL DRAWING AND FEATURES

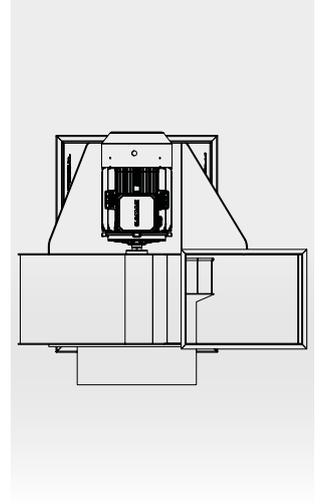
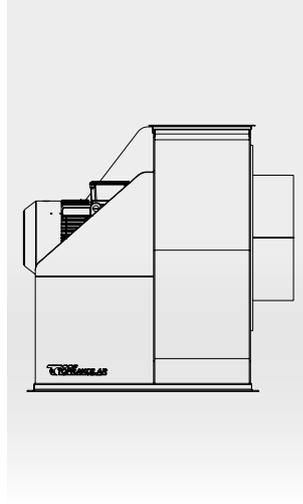
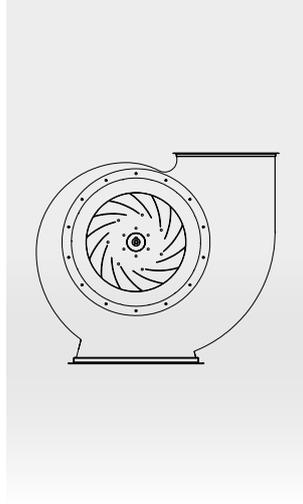
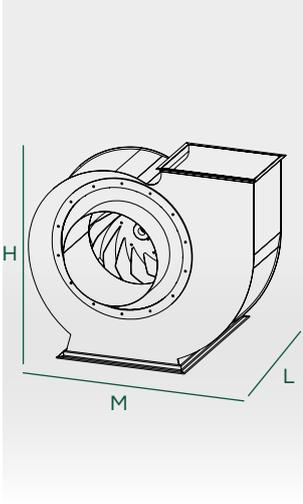

MODEL MODEL	MOTOR GÜCÜ MOTOR POWER	DEVİR REVOLUTION	KAPASİTE CAPACITY	M-L-H
<b>TM-HF20</b>	11kW	1500RPM	20000m <sup>3</sup> /h	<b>M: 1275<sup>mm</sup></b> <b>L: 980<sup>mm</sup></b> <b>H: 1150<sup>mm</sup></b>
<b>TM-HF30</b>	18,5kW	1500RPM	30000m <sup>3</sup> /h	<b>M: 1500<sup>mm</sup></b> <b>L: 1100<sup>mm</sup></b> <b>H: 1300<sup>mm</sup></b>
<b>TM-HF45</b>	37kW	1500RPM	45000m <sup>3</sup> /h	<b>M: 1850<sup>mm</sup></b> <b>L: 1350<sup>mm</sup></b> <b>H: 1700<sup>mm</sup></b>



### TR

Hava fanı, havayı hareket ettirerek soğutma, havalandırma ve hava dolaşımını sağlamak için kullanılır. Hava fanları, enerji verimliliği ve düşük gürültü seviyeleriyle tasarlanarak kullanıcı konforunu artırır. Farklı boyut ve güç seçenekleri ile çeşitli ihtiyaçlara uygun çözümler sunar.

### EN

An air fan is used to move air, providing cooling, ventilation, and air circulation. Air fans are designed with energy efficiency and low noise levels to enhance user comfort. They offer solutions for various needs with different size and power options.



## HAVA SİKLONU

AIR CYCLONE

# TEKNİK ÇİZİM VE ÖZELLİKLER

## TECHNICAL DRAWING AND FEATURES



www.toprakcilar.com

MODEL MODEL	GİRİŞ AĞZI INLET	ATIŞ AĞZI DISCHARGE OPENING	ÜRÜN ÇIKIŞ AĞZI PRODUCT OUTLET	KAPASİTE CAPACITY	Ø-H
<b>TM-HS30</b>	850mmx300mm	750Ø	200Ø	30000m <sup>3</sup>	Ø: 1450mm H: 4400mm
<b>TM-HS45</b>	1100mmx400mm	850Ø	200Ø	45000m <sup>3</sup>	Ø: 1900mm H: 4400mm



### TR

Hava siklonu, hava akışındaki toz ve partikülleri ayırtmak için kullanılır. Siklonlar, santrifüj kuvveti kullanarak ağır parçacıkları hava akışından ayırır ve toplar. Enerji tasarrufu sağlayarak işletme maliyetlerini düşürür. Farklı boyut ve kapasitelerde üretilen siklonlar, çeşitli endüstriyel ihtiyaçlara uygun çözümler sunar.

### EN

An air cyclone is used to separate dust and particles from the airflow. Cyclones use centrifugal force to separate and collect heavier particles from the air stream. They provide energy savings and reduce operating costs. Produced in different sizes and capacities, cyclones offer solutions suitable for various industrial needs.

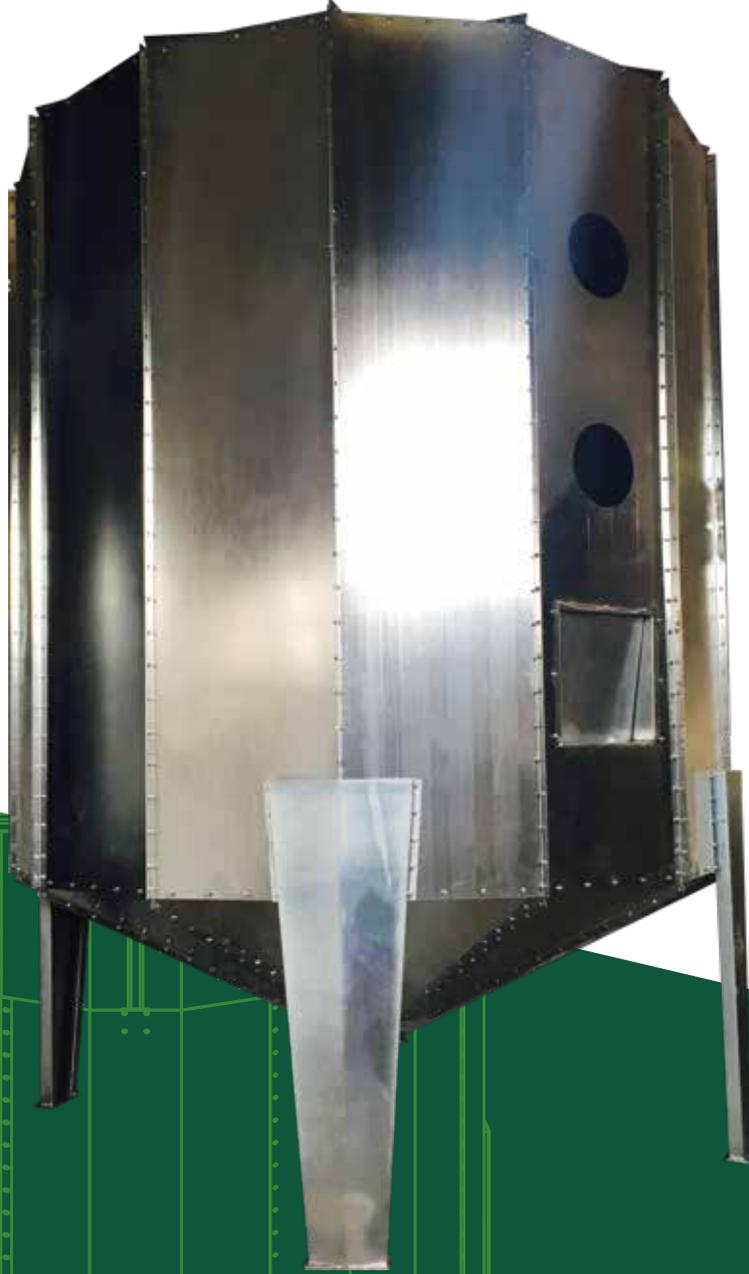

**STOK SİLOSU**

STORAGE SILO

# TEKNİK ÇİZİM VE ÖZELLİKLER

## TECHNICAL DRAWING AND FEATURES

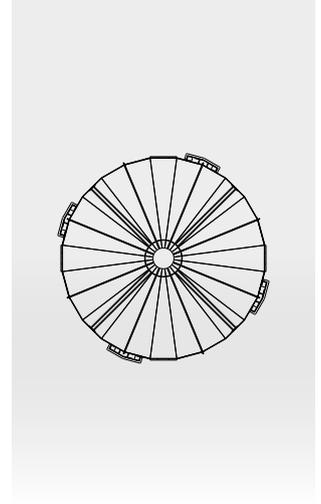
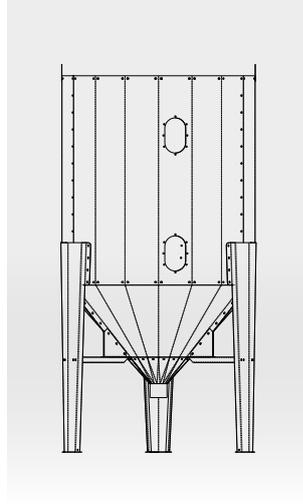
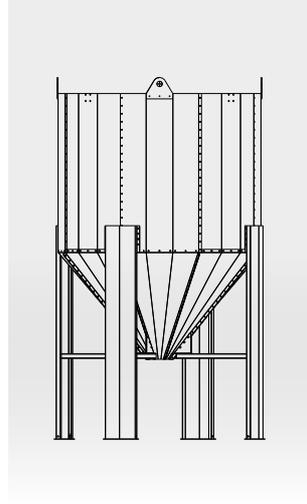
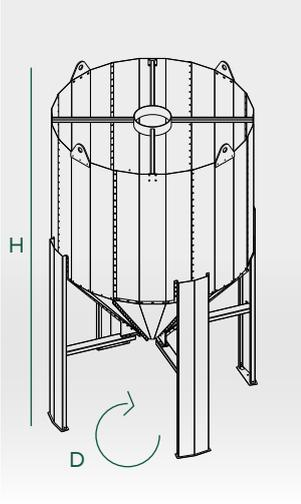

MODEL MODEL	GÖVDE YAPISI BODY STRUCTURE	ROTOFLOW	KAPASİTE CAPACITY	D-H
<b>TM-SS3</b>	KROM SAC GALVANİZ	YOK	2,5m <sup>3</sup>	<b>D: 1400<sup>mm</sup></b> <b>H: 3000<sup>mm</sup></b>
<b>TM-SS24</b>	KROM SAC GALVANİZ	YOK	24m <sup>3</sup>	<b>D: 2200<sup>mm</sup></b> <b>H: 3600<sup>mm</sup></b>
<b>TM-SS24R</b>	KROM SAC GALVANİZ	VAR	24m <sup>3</sup>	<b>D: 2200<sup>mm</sup></b> <b>H: 3600<sup>mm</sup></b>



### TR

Firmamız endüstri makinalarının yanı sıra Toz ve granül ürünlerin depolanmasında kullanılan Modüler ve kaynaklı silolar imal etmektedir. Siloların dolun ve boşaltım işlemleri pnomatik ve konveyörlerle yapılacak şekilde donatılmaktadır. Ürün cinsine göre sızdırmazlık ekipmanları opsiyonel olarak sağlanmaktadır.

### EN

Together with the industrial machines our company manufactures modular and welded silos used for storing powder and granular products. The silos are equipped with pneumatic systems and conveyors for filling and discharging. Sealing equipment is optionally provided according to the product type.

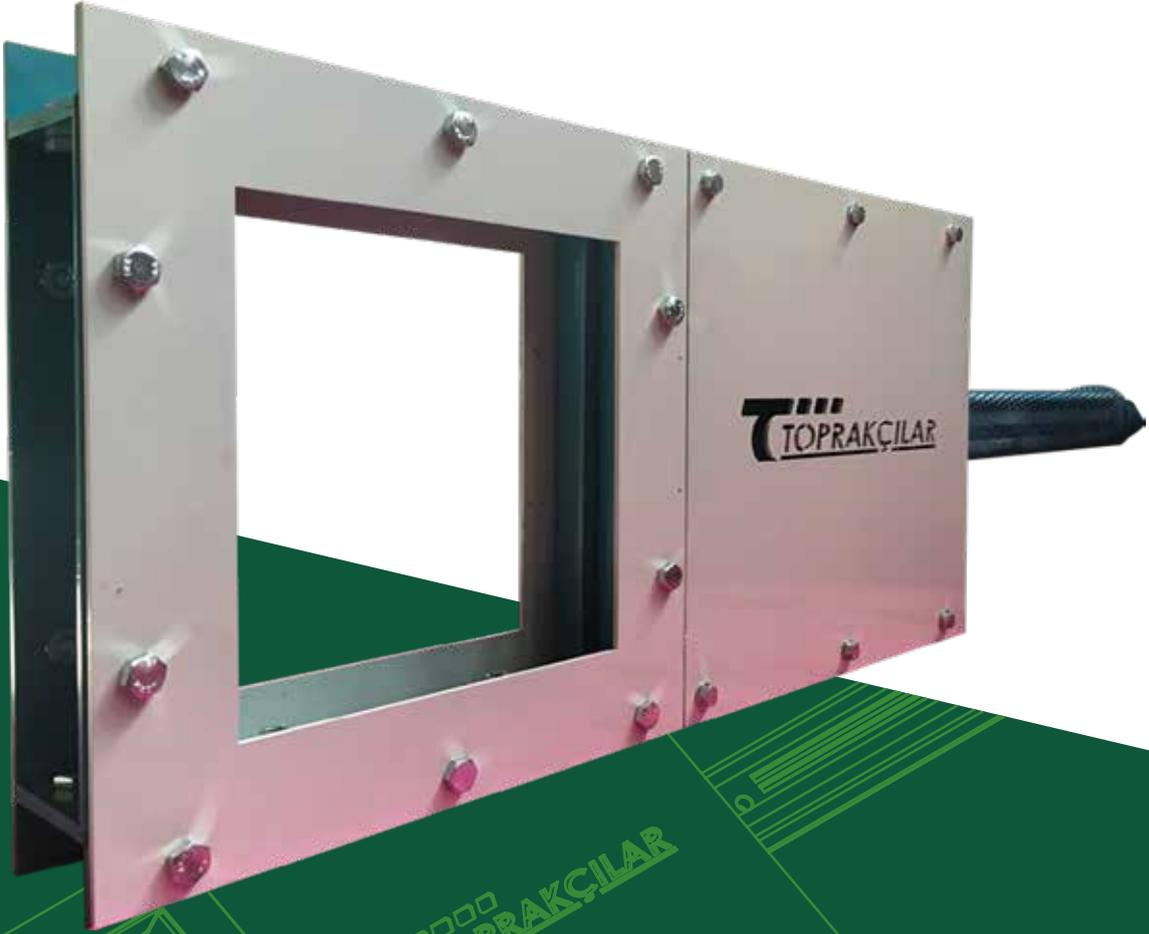

## PNOMATİK SÜRGÜ

PNEUMATIC SLIDERS

# TEKNİK ÇİZİM VE ÖZELLİKLER

## TECHNICAL DRAWING AND FEATURES

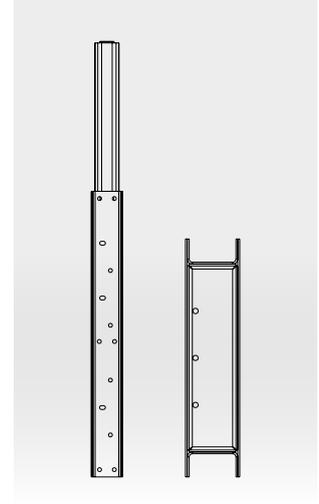
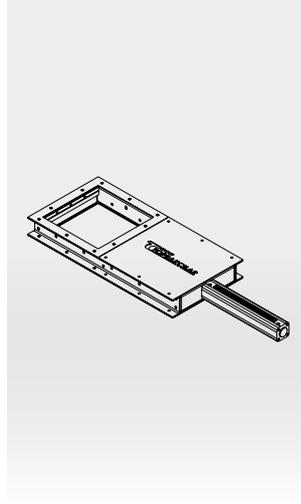
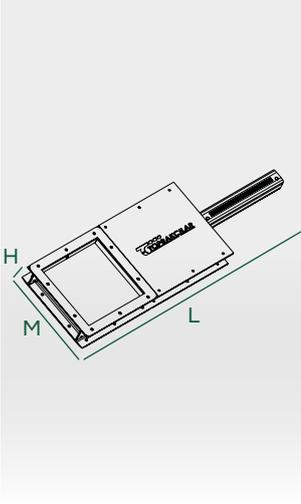

MODEL MODEL	PİSTON ÇAPI PISTON DIAMETER	PİSTON UZUNLUĞU PISTON LENGTH	KLEPE AĞZI VALVE OPENING	M-L-H
<b>TM-PS20</b>	40 <sup>mm</sup>	200 <sup>mm</sup>	200 <sup>mm</sup> x 200 <sup>mm</sup>	<b>M: 280<sup>mm</sup></b> <b>L: 750<sup>mm</sup></b> <b>H: 86<sup>mm</sup></b>
<b>TM-PS30</b>	40 <sup>mm</sup>	300 <sup>mm</sup>	300 <sup>mm</sup> x 300 <sup>mm</sup>	<b>M: 380<sup>mm</sup></b> <b>L: 1100<sup>mm</sup></b> <b>H: 86<sup>mm</sup></b>
<b>TM-PS35</b>	50 <sup>mm</sup>	350 <sup>mm</sup>	350 <sup>mm</sup> x 350 <sup>mm</sup>	<b>M: 430<sup>mm</sup></b> <b>L: 1200<sup>mm</sup></b> <b>H: 86<sup>mm</sup></b>
<b>TM-PS40</b>	63 <sup>mm</sup>	400 <sup>mm</sup>	400 <sup>mm</sup> x 400 <sup>mm</sup>	<b>M: 600<sup>mm</sup></b> <b>L: 1700<sup>mm</sup></b> <b>H: 100<sup>mm</sup></b>
<b>TM-PS50</b>	63 <sup>mm</sup>	500 <sup>mm</sup>	500 <sup>mm</sup> x 500 <sup>mm</sup>	<b>M: 600<sup>mm</sup></b> <b>L: 1830<sup>mm</sup></b> <b>H: 100<sup>mm</sup></b>



### TR

Pnömatik sürgü, malzemelerin akışını kontrol etmek için kullanılır. Sıkıştırılmış hava kullanarak kayan bir kapıyı açar ve kapatır, böylece malzeme boşaltımını hassas bir şekilde kontrol eder. Pnömatik sürgüler, tıkanma riskini azaltarak ve düzgün çalışmayı sağlayarak güvenilir performans sunar. Malzeme taşıma sistemlerinde verimlilik ve üretkenliği artırmaya katkıda bulunur.

### EN

Pneumatic slide gate is used to control the flow of materials. It uses compressed air to open and close a sliding gate, allowing for precise control of material discharge. Pneumatic slide gates provide reliable performance by reducing the risk of blockages and ensuring smooth operation. They contribute to increased efficiency and productivity in material handling systems.



# OTOMATİK TORBALAMA KANTARI

AUTOMATIC BAGGING SCALE

# TEKNİK ÇİZİM VE ÖZELLİKLER

## TECHNICAL DRAWING AND FEATURES

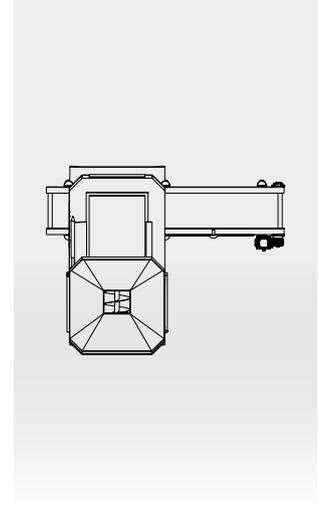
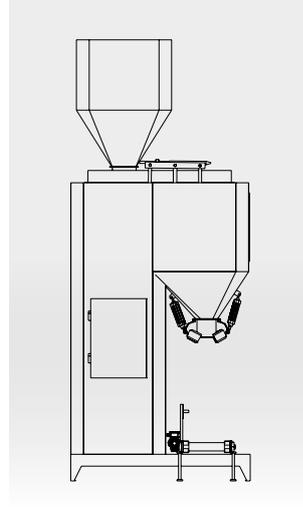
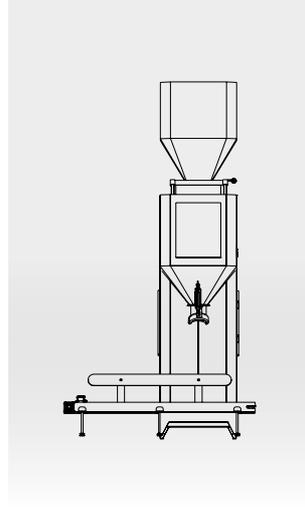
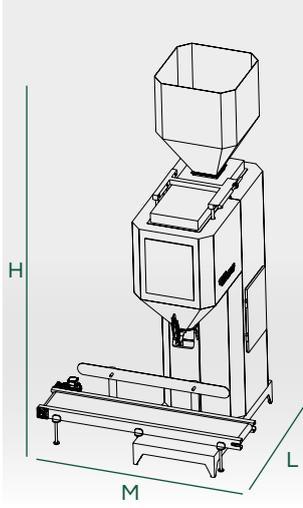

MODEL MODEL	MOTOR GÜCÜ MOTOR POWER	TARTIM TİPİ WEIGHING TYPE	KEFE ADEDİ NUMBER OF PANS	KAPASİTE CAPACITY	M-L-H
<b>TM-OTK10</b>	1,5kW	Loadcell	Tek kefli Single-pan	5000-15000Kg/h	<b>M: 2000<sup>mm</sup></b> <b>L: 1500<sup>mm</sup></b> <b>H: 3750<sup>mm</sup></b>
<b>TM-OTK20</b>	2x1,5kW	Loadcell	Çift kefli Double-pan	15000-30000Kg/h	<b>M: 3000<sup>mm</sup></b> <b>L: 1500<sup>mm</sup></b> <b>H: 3750<sup>mm</sup></b>



### TR

Otomatik torbalama kantarı, çeşitli endüstriyel ürünlerin hassas bir şekilde tartılıp torbalanmasını sağlar. Özellikle toz, granül ve pelet gibi dökme malzemelerin ambalajlanmasında kullanılır. Yüksek hassasiyetli tartım sistemleri sayesinde ürünlerin doğru miktarda paketlenmesini garanti eder. Üretim verimliliğini artırırken insan hatasını en aza indirir. Torbalama işlemi sırasında ürün kaybını önler ve ambalajlama sürecini hızlandırır.

### EN

An automatic bagging scale ensures precise weighing and bagging of various industrial products. It is particularly used for packaging bulk materials such as powders, granules, and pellets. With high-precision weighing systems, it guarantees the accurate amount of product in each package. It increases production efficiency while minimizing human error. The bagging process prevents product loss and speeds up the packaging process.



## AÇILI KONVEYÖR

ANGLED CONVEYOR

# TEKNİK ÇİZİM VE ÖZELLİKLER

## TECHNICAL DRAWING AND FEATURES

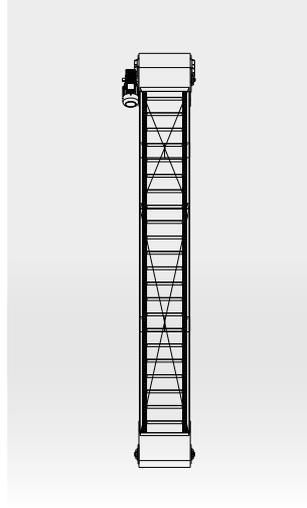
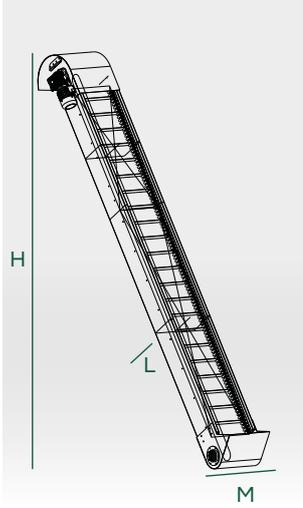

www.toprakcilarmakina.com

MODEL MODEL	MOTOR GÜCÜ MOTOR POWER	DEVİR REVOLUTION	FIRFIR YÜKSEKLİĞİ SCREEN HEIGHT	M-L-H
<b>TM-AK15</b>	1,5kW	50RPM	40 <sup>mm</sup>	<b>M: 470<sup>mm</sup></b> <b>L: 400<sup>mm</sup></b> <b>H: 5300<sup>mm</sup></b>
<b>TM-AK22</b>	2,2kW	50RPM	40 <sup>mm</sup>	<b>M: 570<sup>mm</sup></b> <b>L: 400<sup>mm</sup></b> <b>H: 5300<sup>mm</sup></b>
<b>TM-AK30</b>	3kW	50RPM	50 <sup>mm</sup>	<b>M: 670<sup>mm</sup></b> <b>L: 400<sup>mm</sup></b> <b>H: 5300<sup>mm</sup></b>



### TR

Açılı konveyör, yatay veya dikey şekilde ürünlerin bir yerden başka bir yere taşınmasında kullanılan makinalardır. Kullanılacak yere ve ürünün özelliğine göre konveyör bant seçimi yapılmaktadır. Konveyör bandı gıda tüzüğüne uygun olarak istenilen genişlik ve uzunlukta yapılabilmektedir. Konveyör bandın kapasitesi taşınan ürünün cinsine göre değişmektedir.

### EN

Conveyors are machines used for transporting products horizontally or vertically from one place to another. The selection of conveyor belts depends on the destination and the characteristics of the product. Conveyor belts can be manufactured in widths and lengths that comply with food regulations. The capacity of the conveyor belt varies depending on the type of product being transported.

INDUSTRIAL FEED PELLET MACHINES

Since 1985  
**TOPRAKÇILAR**  
MAKİNA SANAYİ VE TİC. LTD. ŞTİ



**ELEVATÖR**

ELEVATOR

# TEKNİK ÇİZİM VE ÖZELLİKLER

## TECHNICAL DRAWING AND FEATURES

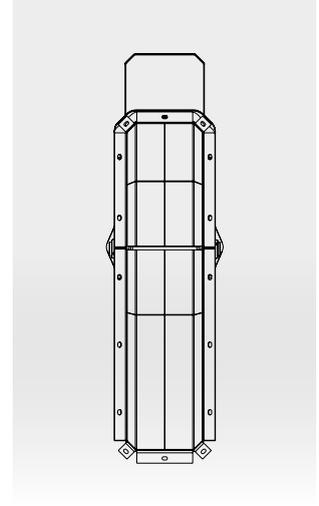
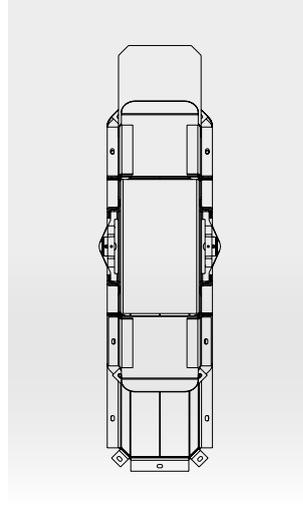
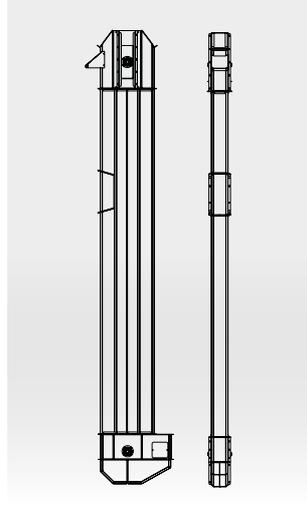
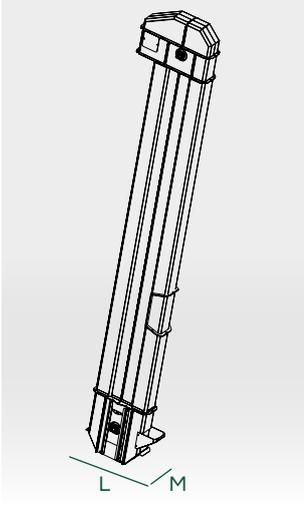

www.toprakcilarmakina.com

MODEL MODEL	MOTOR GÜCÜ MOTOR POWER	KOVA ÖLÇÜSÜ BUCKET SIZE	KAYIŞ ÖLÇÜSÜ BELT SIZE	M-L
<b>TM-E15</b>	2,2kW	140 <sup>mm</sup>	160 <sup>mm</sup>	<b>M: 260<sup>mm</sup></b> <b>L: 850<sup>mm</sup></b>
<b>TM-E30</b>	3kW	240 <sup>mm</sup>	260 <sup>mm</sup>	<b>M: 360<sup>mm</sup></b> <b>L: 960<sup>mm</sup></b>



### TR

Kovalı elevatör ürünlerin Dikey şekilde bir yerden başka bir yere taşınmasında kullanılan makinalardır. Kayış üzerine monte edilmiş özel üretilmiş kovaların her bir seferde hacmi kadar ürün almasıyla taşıma işlemi yapmaktadır. Kullanılacak yere ve ürünün özelliğine göre ölçü ve kova seçimi yapılmaktadır. Elevatör kapasitesi taşınan ürünün cinsine göre değişmektedir.

### EN

Bucket elevators are used for vertically transporting products from one place to another. The transport process is carried out by specially manufactured buckets mounted on a belt, each taking up a volume of product per cycle. The size and bucket selection are made according to the place of use and the characteristics of the product. The capacity of the elevator varies depending on the type of product being transported.





# BORU HELEZON

SCREW CONVEYOR

# TEKNİK ÇİZİM VE ÖZELLİKLER

## TECHNICAL DRAWING AND FEATURES

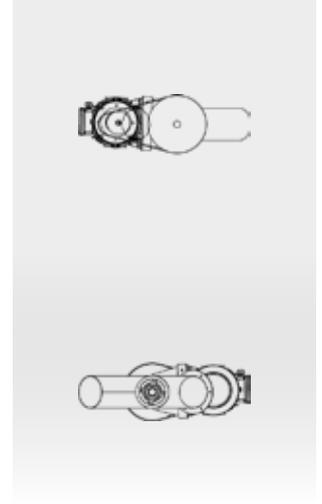
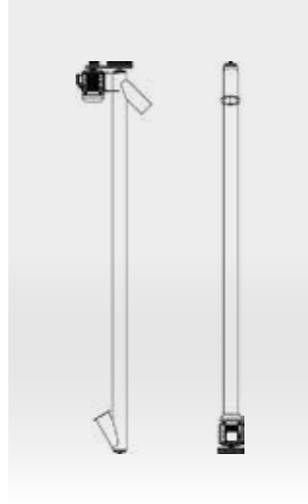
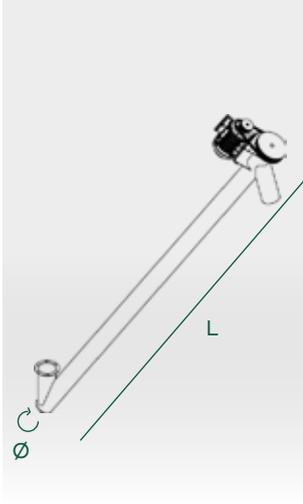

www.toprakcilarmakina.com

MODEL MODEL	MOTOR GÜCÜ MOTOR POWER	HELEZON ÇAPI SCREW DIAMETER	Ø-L
TM-BH10	2,2kW	168Ø	Ø: 250 <sup>mm</sup> L: 6000 <sup>mm</sup>
TM-BH15	3kW	219Ø	Ø: 320 <sup>mm</sup> L: 6000 <sup>mm</sup>
TM-BH20	4kW	273Ø	Ø: 400 <sup>mm</sup> L: 6000 <sup>mm</sup>



### TR

Vidalı konveyör sarmal burgu şeklindeki borulu taşıma sistemleridir, ürünleri dikey veya yatay konumlarda taşımakta kullanılan makinalardır. Helezonlar belirli bir adım hesabına göre imal edildikleri için vidalı konveyör diye adlandırılırlar. Ürünün cinsi, Boyutu, üretim tesisinin kapasitesi ve nemine göre değişik ebatlarda ve tasarımlarda üretilmektedir.

### EN

Screw conveyors are spiral auger shaped pipe transport systems, they are machines used to transport products in vertical or horizontal positions. Since the augers are manufactured according to a certain step calculation, they are called screw conveyors. They are manufactured in different sizes and designs according to the type of product, size, capacity and humidity level of the product.



## U TİPİ HELEZON

U-SHAPED SCREW CONVEYOR



# TEKNİK ÇİZİM VE ÖZELLİKLER

## TECHNICAL DRAWING AND FEATURES

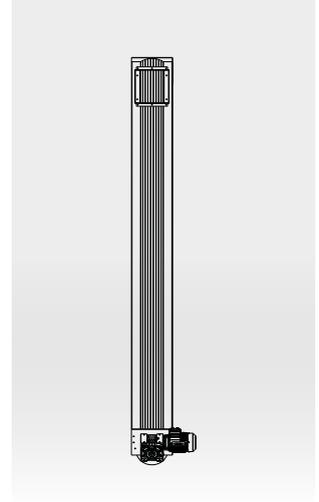
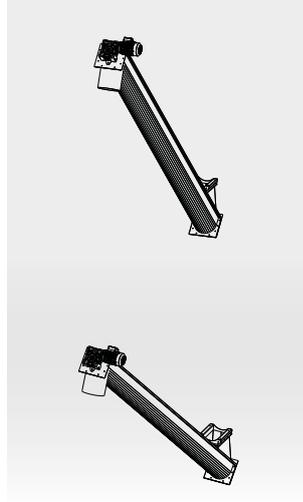
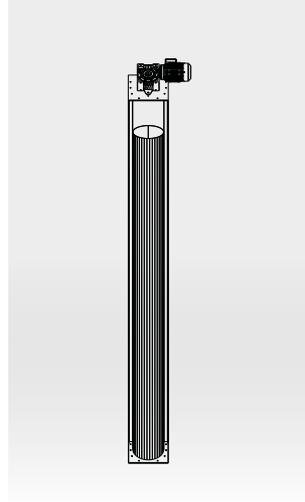
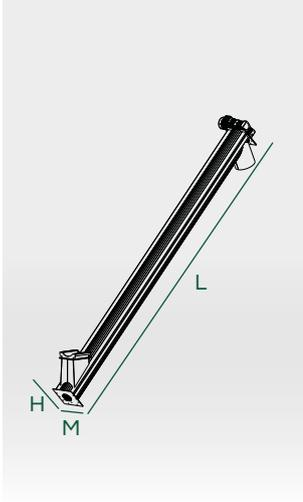

www.toprakcilarmakina.com

MODEL MODEL	MOTOR GÜCÜ MOTOR POWER	HELEZON ÇAPI SCREW DIAMETER	M-L-H
<b>TM-UH15</b>	2,2kW	250Ø	<b>M: 330<sup>mm</sup></b> <b>L: 530<sup>mm</sup></b> <b>H: 380<sup>mm</sup></b>
<b>TM-UH25</b>	3kW	300Ø	<b>M: 380<sup>mm</sup></b> <b>L: 580<sup>mm</sup></b> <b>H: 380<sup>mm</sup></b>
<b>TM-UH35</b>	4kW	350Ø	<b>M: 430<sup>mm</sup></b> <b>L: 630<sup>mm</sup></b> <b>H: 380<sup>mm</sup></b>
<b>TM-UH45</b>	5,5kW	450Ø	<b>M: 550<sup>mm</sup></b> <b>L: 750<sup>mm</sup></b> <b>H: 380<sup>mm</sup></b>

### TR

U tipi helezon, malzemelerin taşınması ve işlenmesi için kullanılır. Boru şeklinde kapalı bir yapı içinde dönen bir vida ile çalışır. Toz, granül ve pelet gibi dökme malzemelerin yatay veya hafif eğimli bir şekilde taşınmasını sağlar. U tipi helezonlar, hijyenik ve sızdırmaz yapıları sayesinde özellikle gıda ve kimya endüstrilerinde de tercih edilir. Malzemenin taşınması sırasında toz oluşumunu minimize ederek çevre temizliğini sağlar.

### EN

A tube-type screw conveyor is used for conveying and processing materials. It operates with a rotating screw inside a closed tube-shaped structure. It facilitates the horizontal or slightly inclined movement of bulk materials such as powder, granules, and pellets. Tube-type screw conveyors are preferred in food and chemical industries due to their hygienic and leak-proof design. They minimize dust formation during material handling, ensuring environmental cleanliness.





**YÜKLEME BANDI**

LOADING TAPE

# TEKNİK ÇİZİM VE ÖZELLİKLER

## TECHNICAL DRAWING AND FEATURES

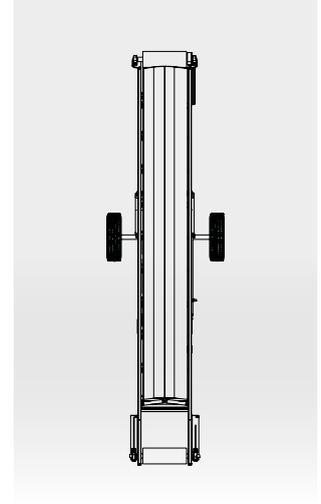
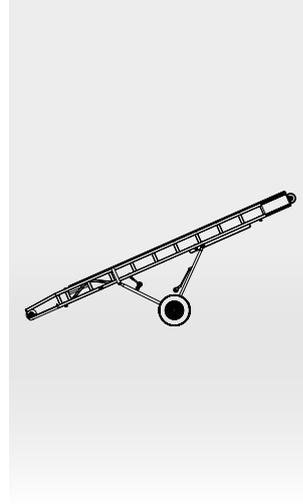
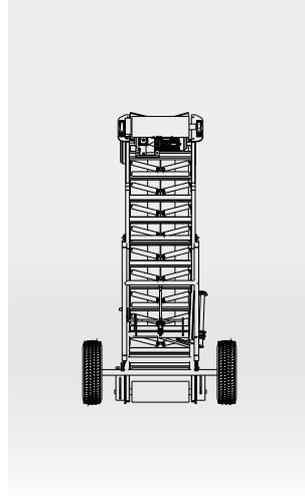
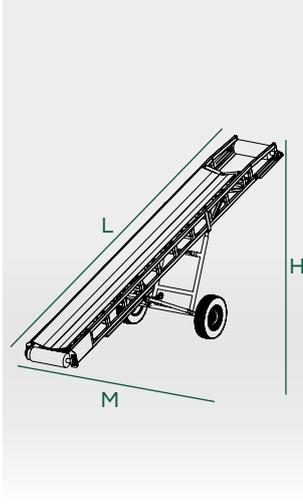

MODEL MODEL	MOTOR GÜCÜ MOTOR POWER	DEVİR REVOLUTION	BANT GENİŞLİĞİ BANDWIDTH	KAPASİTE CAPACITY	M-L-H
<b>TM-AK15</b>	1,5kW	50RPM	500 <sup>mm</sup>	6-9m <sup>3</sup> /h	<b>M: 1580<sup>mm</sup></b> <b>L: 4500<sup>mm</sup></b> <b>H: 8000<sup>mm</sup></b>
<b>TM-AK22</b>	2,2kW	50RPM	600 <sup>mm</sup>	8-12m <sup>3</sup> /h	<b>M: 1580<sup>mm</sup></b> <b>L: 4500<sup>mm</sup></b> <b>H: 10000<sup>mm</sup></b>
<b>TM-AK30</b>	3kW	50RPM	700 <sup>mm</sup>	10-12m <sup>3</sup> /h	<b>M: 1580<sup>mm</sup></b> <b>L: 4500<sup>mm</sup></b> <b>H: 12000<sup>mm</sup></b>



### TR

Çuvallanmış ürünlerin istifleme veya araçlara yükleme amacıyla kullanılır. Konveyör bant redüktör yardımıyla dönüşünü sağlamaktadır. Konveyör bandı gıda tüzüğüne uygun olarak istenilen genişlik ve uzunlukta yapılabilmektedir. Nakliye bandının kapasitesi taşınacak ürünün özelliğine göre değişmektedir.

### EN

Conveyor belt is used for stacking or loading sacked products onto vehicles. It rotates with the help of a conveyor belt reducer. The conveyor belt can be made to the desired width and length according to food regulations. The capacity of the conveyor belt varies depending on the characteristics of the product to be transported.



## OTOMASYON VE KONTROL PANOSU

AUTOMATION AND CONTROL PANEL

# TEKNİK ÇİZİM VE ÖZELLİKLER

## TECHNICAL DRAWING AND FEATURES

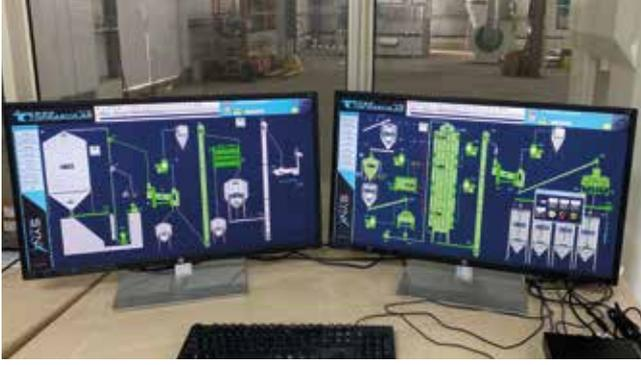

### TR

Otomasyon ve kontrol panosu, üretim süreçlerini izlemek ve yönetmek için kullanılan bir sistemdir. Bu panolar, makinelerin ve ekipmanların otomatik olarak çalışmasını sağlayarak, insan müdahalesini minimuma indirir ve üretim verimliliğini artırır. Sensörler, motorlar ve diğer elektronik bileşenlerle entegre olan kontrol panoları, süreçlerin anlık izlenmesini ve gerektiğinde hızlı müdahale edilmesini mümkün kılar. Ayrıca, enerji tüketimini optimize ederek maliyet tasarrufu sağlar ve üretim hattındaki hataları minimize eder. Modern otomasyon panoları, üretim sürecinin daha güvenli, tutarlı ve verimli olmasına katkıda bulunur.

### EN

An automation and control panel is a system used to monitor and manage production processes. These panels allow machines and equipment to operate automatically, minimizing human intervention and increasing production efficiency. Integrated with sensors, motors, and other electronic components, control panels enable real-time monitoring and quick response when needed. Additionally, they optimize energy consumption, leading to cost savings and minimizing errors in the production line. Modern automation panels contribute to making the production process safer, more consistent, and efficient.





*Doğadan gelen,  
teknolojiyle şekillenen*

*Coming from nature,  
shaped by technology*



INSTAGRAM



YOUTUBE



WEBSITE



LINKEDIN

[www.toprakcilarmakina.com](http://www.toprakcilarmakina.com)

ORGANİZE SANAYİ BÖLGESİ 13. SOKAK NO:3  
MERKEZ / KARAMAN / TÜRKİYE