

**TOPRAKÇILAR**  
MAKİNA SANAYİ VE TİC. LTD. ŞTİ

Since 1985

**BULGUR ÜRETİM MAKİNALARI**

**BULGUR PRODUCTION MACHINES**



[www.toprakcilarmakina.com](http://www.toprakcilarmakina.com)

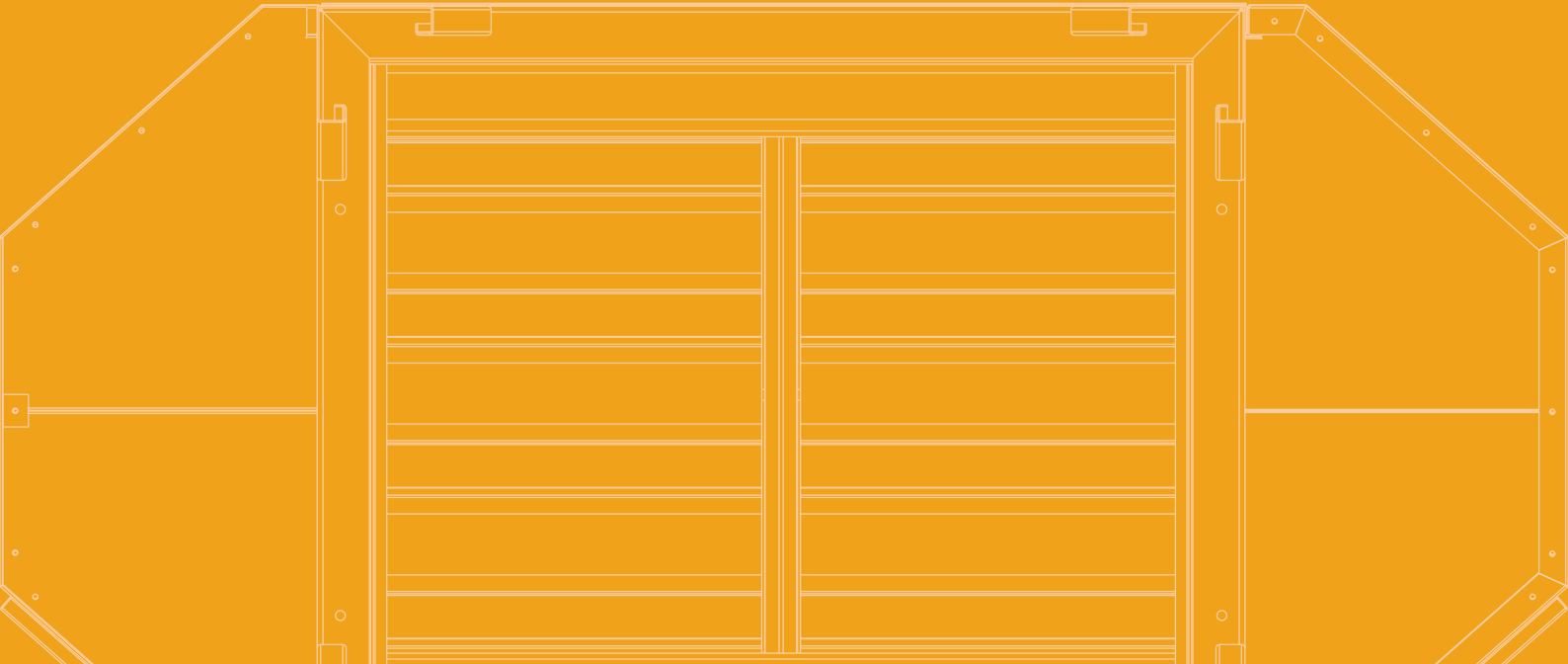

## TR

Bulgurun temel bileşenleri şunlardır:

**Karbonhidratlar:** Bulgurun büyük bir kısmını oluşturan karbonhidratlar, özellikle nişasta formunda bulunur ve enerji kaynağı olarak önemli bir rol oynar.

**Proteinler:** Buğdayın doğal protein içeriği, bulgurun besleyici değerini artırır. Özellikle gluten, bulgurda önemli bir protein kaynağıdır.

**Lifler:** Bulgur, kepek ve endosperm tabakalarından gelen yüksek lif içeriği sayesinde sindirim sistemine faydalıdır.

**Vitaminler ve Mineraller:** Bulgur, B vitaminleri (özellikle B1 ve B6) ve demir, magnezyum, fosfor gibi mineraller açısından zengindir.

**Yağlar:** Bulgur, düşük yağ içeriğine sahiptir, bu da onu sağlıklı bir diyet için uygun bir gıda yapar. İçerdiği yağlar, genellikle doymamış yağ asitleri olup, kalp sağlığına katkıda bulunur.

Bulgur, geleneksel olarak birçok kültürde temel bir gıda olarak tüketilir ve özellikle lif, protein ve vitamin açısından zengin bir besin kaynağıdır.

## EN

The main components of bulgur are as follows:

**Carbohydrates:** Carbohydrates make up the majority of bulgur, particularly in the form of starch, and play a significant role as an energy source.

**Proteins:** The natural protein content of wheat enhances the nutritional value of bulgur. Gluten, in particular, is an important protein found in bulgur.

**Fibers:** Bulgur is rich in fiber, which comes from the bran and endosperm layers, and benefits the digestive system.

**Vitamins and Minerals:** Bulgur is rich in B vitamins (especially B1 and B6) and minerals such as iron, magnesium, and phosphorus.

**Fats:** Bulgur has a low fat content, making it a suitable food for a healthy diet. The fats it contains are generally unsaturated fatty acids, which contribute to heart health.

Bulgur is traditionally consumed as a staple food in many cultures and is particularly rich in fiber, protein, and vitamins.



# HAKKIMIZDA

## ABOUT US



### TR

Toprakçılar Makina, 1985 yılından bu yana bulgur, hayvan yemi ve odun peleti sektörlerinde yenilikçi çözümleri mühendislik uzmanlığıyla birleştiren öncü bir makine ve teknoloji tedarikçisidir. 10.000 m<sup>2</sup> açık ve 4.000 m<sup>2</sup> kapalı alanı kapsayan tesislerimizde, hassas üretim ve yüksek kalite standartlarını sürdürmeye odaklanıyoruz. Sadece makineler sunmuyoruz; her makine ile bulgur üretiminin geleceğini şekillendirmeye ve sektöre kalıcı katkılar sağlamaya kararlıyız. Ünümüz, yalnızca ürünlerimizin kalitesine değil, aynı zamanda sağladığımız operasyonel verimliliğe dayanmaktadır. Toprakçılar ailesinin bir parçası olarak, yenilik ve liderlik konusundaki bağlılığımız işimizin her yönünde kendini göstermektedir.

### EN

Toprakçılar Makina is a leading machinery and technology supplier in the bulgur, animal feed, and wood pellet sectors, combining innovation with engineering expertise since 1985. Our facilities, spanning 10,000 m<sup>2</sup> outdoors and 4,000 m<sup>2</sup> indoors, are dedicated to precise production and maintaining high-quality standards. We offer more than just machinery; we are committed to shaping the future of bulgur production and making lasting contributions to the industry with each machine we deliver. Our reputation is built not only on our products but also on the operational efficiency we provide. As part of the Toprakçılar family, our dedication to innovation and leadership is evident in every aspect of our operations.

# ÜRETİMDEN BİZ

FROM PRODUCTION, WE





## BULGUR ÜRETİM TESİSİ

BULGUR  
PRODUCTION LINE



## AHŞAP PELET ÜRETİM TESİSİ

WOOD PELLET  
PRODUCTION LINE



## PELET YEM ÜRETİM TESİSİ

FEED MILL  
PRODUCTION LINE



BULUNDUĞUMUZ SEKTÖRLER / SECTORS SERVED

# BULGUR ÜRETİM MAKİNALARI

## BULGUR PRODUCTION MACHINES

### TEMEL UNSURLAR

#### BASIC ELEMENTS

#### TR

Bulgur üretim hattı, buğdayın çeşitli işlemlerden geçirilerek bulgur haline getirilmesini sağlayan bir dizi makine ve işlemden oluşur. İşte bulgur üretim hattının temel unsurları:

**Temizleme:** İlk temizleme işleminde taş ayırıcılar, vibrasyonlu elekler ve hava üfleyiciler kullanılarak buğdayın yüzeyindeki ve içindeki yabancı maddeler ayrılır.

**Pişirme:** Buğday haşlama kazanlarında belirli bir sıcaklık ve süreyle pişirilir. Pişirme süresi ve sıcaklığı, buğdayın çeşidine göre ayarlanır.

**Kurutma:** Haşlanmış buğday, kurutma fırınlarında yavaşça kurutulur. Kurutma işlemi sırasında buğdayın çatlamaması için sıcaklık kontrollü olmalıdır.

**Öğütme:** Kurutulmuş buğday değirmenlerde kırılarak bulgur taneciklerine dönüştürülür. Kırma işlemi sırasında farklı elekler kullanılarak istenilen bulgur tanecik boyutu elde edilir.

**Sınıflandırma:** Öğütülmüş bulgur farklı boyutlara ayrılır ve farklı ürün kategorileri oluşturulur.

**Paketleme:** Sınıflandırılan bulgur, otomatik paketleme makinelerinde hijyenik koşullarda paketlenir ve etiketlenir.

#### EN

The bulgur production line consists of a series of machines and processes that transform wheat into bulgur. Here are the basic elements of the bulgur production line:

**Cleaning:** In the initial cleaning process, stone separators, vibrating sieves, and air blowers are used to remove foreign materials from the surface and inside of the wheat.

**Cooking:** The wheat is cooked in boiling tanks at a specific temperature and for a specific duration. The cooking time and temperature are adjusted according to the type of wheat.

**Drying:** Cooked wheat (Bulgur) is slowly dried in a drying tower. During the drying process, the temperature is controlled to prevent the wheat from cracking.

**Grinding:** The dried wheat is crushed into bulgur grains in mills. Different sieves are used during the crushing process to obtain the desired bulgur grain size.

**Classification:** The ground bulgur is separated into different sizes and different product categories are created.

**Packaging:** The classified bulgur is hygienically packaged and labeled in automatic packaging machines.



## İNNOVASYON VE KALİTE

### INNOVATION AND QUALITY

#### TR

Son teknoloji bulgur üretim hattımız, benzersiz verimlilik ve azaltılmış enerji tüketimi sağlamak için ileri mühendislikten yararlanır. Gelişmiş dijital kontroller, otomasyon ve veri analitiği içeren sistemimiz, buğdayın hassas bir şekilde işlenmesini sağlayarak sürekli olarak yüksek kaliteli bulgur elde edilmesini sağlar. Gelişmiş otomasyon ve dijital kontrol sistemleri, üretimin her aşamasını hassasiyetle denetler, hataları en aza indirir ve verimi hızlandırır.

Enerji tasarruflu motorlarımız ve ısı geri kazanım sistemlerimiz, enerji kullanımını azaltmak için tasarlanmıştır; yenilikçi temizlik ve dezenfeksiyon teknolojileri ise optimum hijyen standartlarını korur. Ayrıca, üretim hattımızın modüler tasarımı, çeşitli bulgur türleri ve boyutları üretmek için esneklik sunarak değişen pazar taleplerine hızlı bir şekilde uyum sağlamayı mümkün kılar. Gelişmiş bulgur üretim çözümümüzle yeni bir verimlilik ve uyulanabilirlik düzeyi deneyimleyin.

#### EN

Our state-of-the-art bulgur production line leverages cutting-edge technology and engineering to deliver unparalleled efficiency and reduced energy consumption. Featuring advanced digital controls, automation, and data analytics, our system ensures precise processing of wheat, resulting in consistently high-quality bulgur. The sophisticated automation and digital control systems oversee every stage of production with precision, minimizing errors and accelerating throughput.

Our energy-efficient motors and heat recovery systems are designed to cut down on energy use, while innovative cleaning and disinfection technologies maintain optimal hygiene standards. Additionally, the modular design of our production line offers flexibility to produce various bulgur types and sizes, enabling rapid adaptation to shifting market demands. Experience a new level of efficiency and adaptability with our advanced bulgur production solution.

**TOPRAKÇILAR**  
MAKİNA SANAYİ VE TİC. LTD. ŞTİ

*innovation and quality*



BULGUR ÜRETİM MAKİNALARI / BULGUR PRODUCTION MACHINES



## ÖN TEMİZLEME SEPERATÖRÜ

PRE-CLEANING SEPARATOR



# TEKNİK ÇİZİM VE ÖZELLİKLER

## TECHNICAL DRAWING AND FEATURES

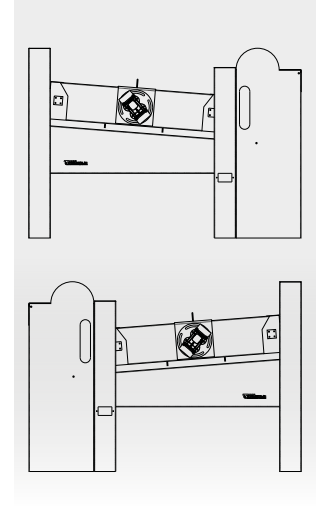
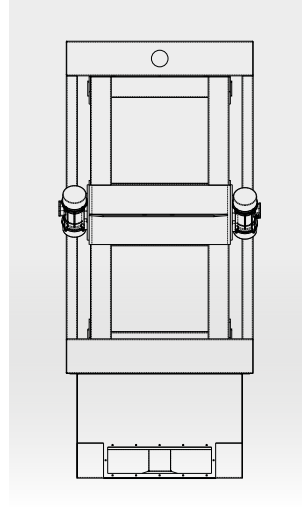
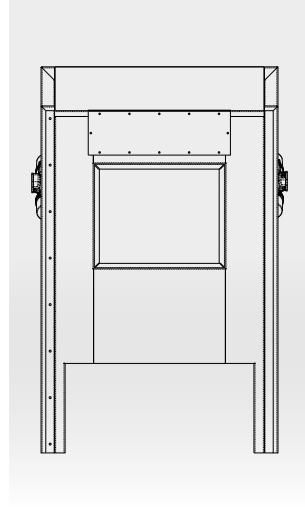
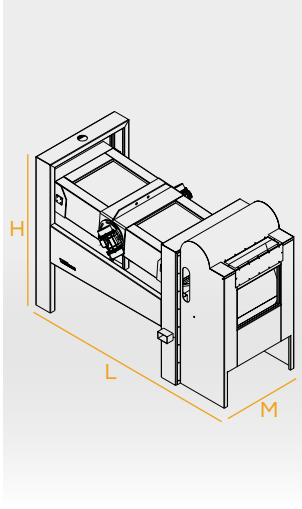

www.toprakcilarmakina.com

MODEL MODEL	MOTOR GÜCÜ MOTOR POWER	HAVA KANALI AIR DUCT	ELEME ALANI SCREENING AREA	KAPASİTE CAPACITY	M-L-H
TM-OTS10	0,55kw	Yok N/A	Tek kat Single layer	1000Kg/h	M: 1250mm L: 2400mm H: 1750mm
TM-OTS25H	2x0,95kw	Var N/A	Çift kat Double layer	2500Kg/h	M: 1350mm L: 3150mm H: 2200mm
TM-OTS50H	2x1,1kw	Var Available	Çift kat Double layer	5000Kg/h	M: 1350mm L: 3600mm H: 2200mm



### TR

Ön temizleme seperatörü, tarımsal ürünlerin işlenmesinde önemli bir rol oynar. Hasat sonrası ürünlerin ilk aşamada yabancı maddelerden arındırılmasını sağlar. Tohumlar, saman, taşlar ve diğer istenmeyen parçacıkları ayırarak ürünlerin kalitesini artırır ve sonraki işlemler için hazır hale getirir. Ön temizleme seperatörleri, titreşim veya hava akımı gibi yöntemlerle çalışır ve bu yöntemler ürünün homojen bir şekilde temizlenmesini sağlar.

### EN

Pre-cleaning separators play an important role in the processing of granular cereal products. It ensures that the products are cleaned of foreign materials in the first stage after harvest. It increases the quality of the products by separating seeds, straw, stones and other unwanted particles and making them ready for the next processes. Pre-cleaning separators work with methods such as vibration or air flow and these methods ensure that the product is cleaned homogeneously.

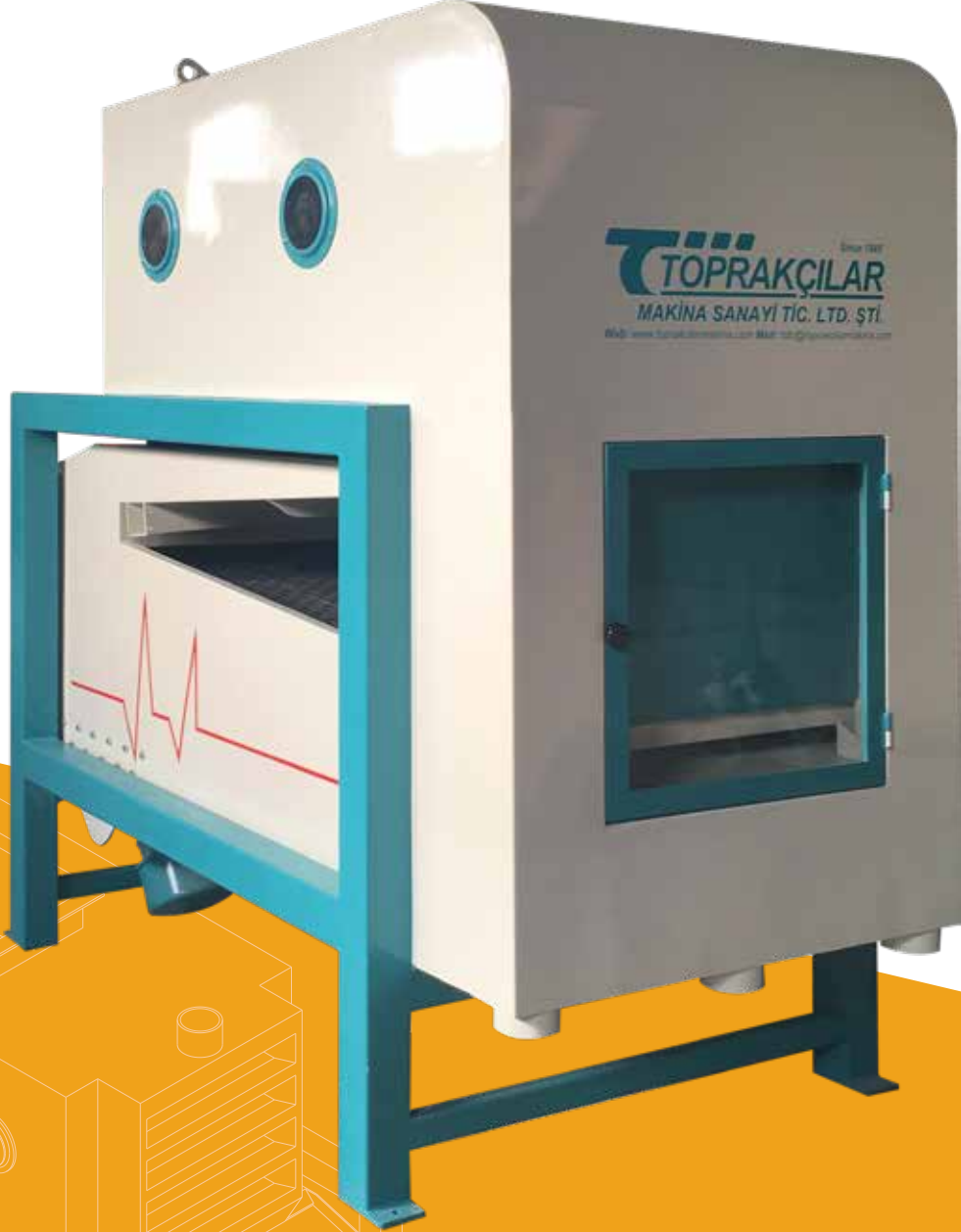

## SASÖR ELEK

VIBRO GRAIN SEPARATOR

# TEKNİK ÇİZİM VE ÖZELLİKLER

## TECHNICAL DRAWING AND FEATURES

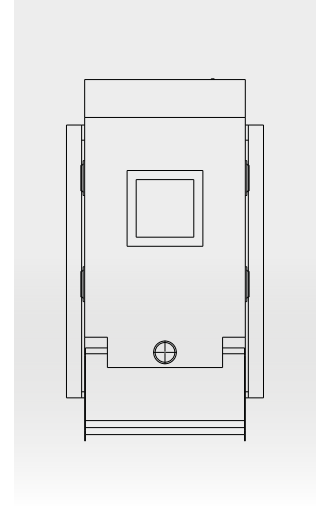
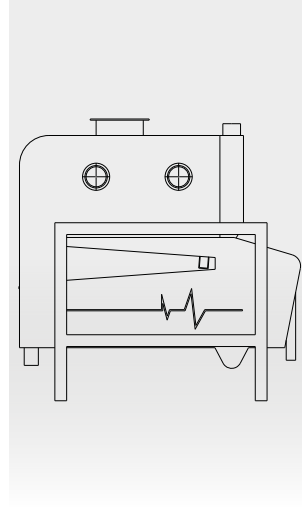
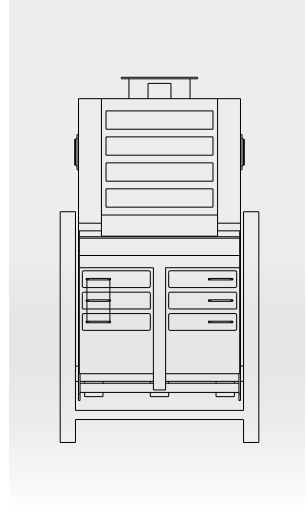
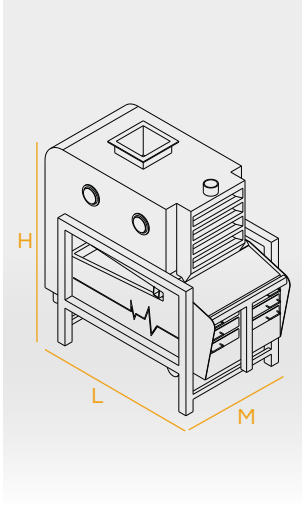

MODEL MODEL	MOTOR GÜCÜ MOTOR POWER	ELEK SAYISI SCREEN NUMBER	KAPASİTE CAPACITY	M-L-H
TM-STE50	2x0,75kW	3	5000Kg/h	M: 1300 <sup>mm</sup> L: 2300 <sup>mm</sup> H: 2300 <sup>mm</sup>
TM-STE100	2x1,1kW	3	10000Kg/h	M: 1300 <sup>mm</sup> L: 2600 <sup>mm</sup> H: 2600 <sup>mm</sup>
TM-STE200	2x1,5kW	3	20000Kg/h	M: 1300 <sup>mm</sup> L: 2900 <sup>mm</sup> H: 2900 <sup>mm</sup>



### TR

Şase altında bir vibro motor bulunur ve şase içinde, uygun boşlukta yer alan iki katlı bir elek sistemi mevcuttur. Şase gövdesi, özel titreşim emici yaylarla korunur. Makina gövdesi eğimli bir yapıya sahip olup, titreşim hareketi sayesinde ürünler makina içinde salınım yapar. Üst elekte, özgül ağırlığı yüksek olan buğday ve taş gibi ürünler kalırken, alt eleğe çöp, kağıt, saman, toprak gibi materyaller geçer ve ayrılır.

### EN

A vibro motor is located underneath the frame, and within the frame, there is a two-layer sieve system positioned with appropriate spacing. The frame body is protected by special vibration-absorbing springs. The machine body has an inclined structure, and the products oscillate within the machine due to the vibrational motion. In the upper sieve, products with a high specific weight, such as wheat and stones, remain, while in the lower sieve, materials like trash, paper, straw, and soil pass through and are separated.



## TOHUM TRIYÖRÜ

SEED SEPARATOR (TRIEURS)

# TEKNİK ÇİZİM VE ÖZELLİKLER

## TECHNICAL DRAWING AND FEATURES

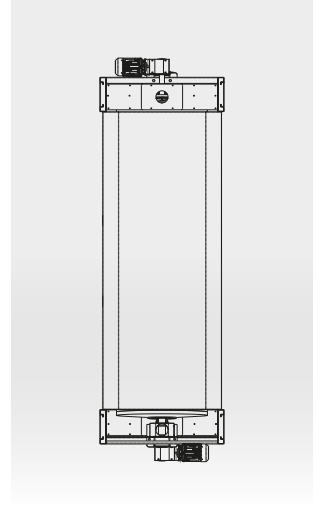
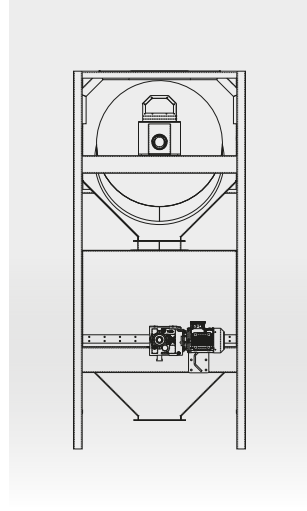
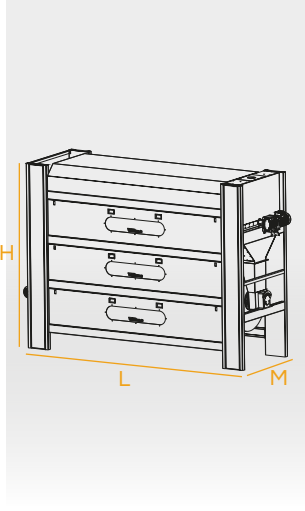

www.toprakcilmakina.com

MODEL MODEL	MOTOR GÜCÜ MOTOR POWER	KULLANIM AMACI PURPOSE OF USE	SİLİNDİR ÇAPI CYLINDER DIAMETER	KAPASİTE CAPACITY	M-L-H
TM-TT25	1,4kW	Arpa Barley	ø600 <sup>mm</sup>	2500Kg/h	M: 900 <sup>mm</sup> L: 2600 <sup>mm</sup> H: 1000 <sup>mm</sup>
TM-TT25	1,4kW	Tohum Seed	ø600 <sup>mm</sup>	2500Kg/h	M: 900 <sup>mm</sup> L: 2600 <sup>mm</sup> H: 1000 <sup>mm</sup>
TM-TT50	2,2kW	Arpa Barley	ø900 <sup>mm</sup>	5000Kg/h	M: 1200 <sup>mm</sup> L: 3600 <sup>mm</sup> H: 2700 <sup>mm</sup>
TM-TT50	45kW	Tohum Seed	ø900 <sup>mm</sup>	5000Kg/h	M: 1200 <sup>mm</sup> L: 3600 <sup>mm</sup> H: 2700 <sup>mm</sup>



### TR

Triyörler, dönen silindirik tamburlar içinde hareket eden tohumların, tambur üzerindeki farklı boyutlardaki deliklerden geçerek ayrılmasını sağlar. Küçük tohumlar, küçük deliklerden geçerken, büyük tohumlar daha büyük deliklerden geçer. Bu makineler, tahıl, bakliyat ve diğer tohum türlerinin boyutlarına ve şekillerine göre ayrılmasında etkili bir şekilde kullanılır.

### EN

Trieurs ensure that the seeds moving in rotating cylindrical drums are separated by passing through holes of different sizes on the drum. Small seeds pass through small holes, while large seeds pass through larger holes. These machines are effectively used to separate grains, legumes, and other types of seeds according to their size and shape.



## TAŞ AYIRICI

STONE SEPARATORS

# TEKNİK ÇİZİM VE ÖZELLİKLER

## TECHNICAL DRAWING AND FEATURES

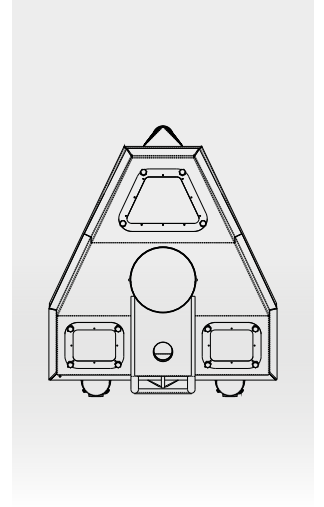
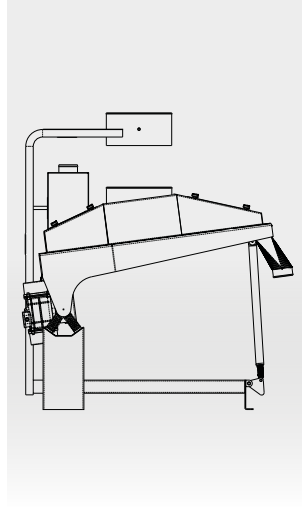
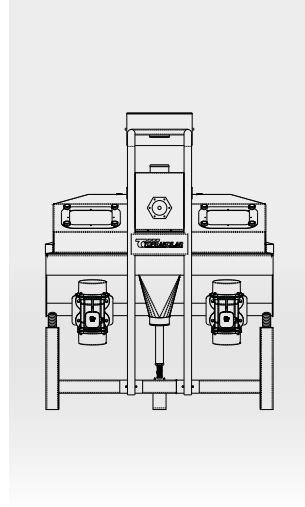
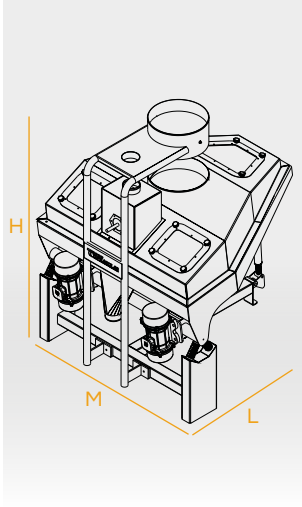

MODEL MODEL	MOTOR GÜCÜ MOTOR POWER	GÖVDE YAPISI BODY STRUCTURE	VİBRASYON ÖNLEYİCİ VIBRATION ABSORBER	KAPASİTE CAPACITY	M-L-H
TM-TA25	2x0,54kW	Metal	Yay Spring	2500Kg/h	M: 1400mm L: 1600mm H: 1800mm
TM-TA50	2x0,94kW	Metal	Yay Spring	5000Kg/h	M: 1600mm L: 1700mm H: 1800mm



### TR

Taş ayırıcılar, tarım ürünlerinin hasat sonrası temizlenmesinde kullanılır. Ürünlerde bulunan taşlar, kumlar, toprak parçacıkları gibi ağır ve istenmeyen yabancı maddeleri ayırmak için özel olarak tasarlanmıştır. Genellikle ürünler, bir taşıyıcı bant veya titreşimli yüzeyler üzerinde ilerlerken, taş ayırıcılar yerçekimi etkisiyle ağır maddelerin aşağıya doğru düşmesini sağlar. Ürünlerdeki istenmeyen maddelerden ayrışma ve temizlik sağlanır, böylece ürün kalitesi artırılır.

### EN

Stone separators are used in the cleaning of agricultural products after harvest. These machines are specially designed to separate heavy and unwanted foreign materials such as stones, sand, soil particles from the products. While the products move on conveyor belts or vibrating surfaces, stone separators ensure that the heavy materials fall down with the effect of gravity. In this way, unwanted materials in the products are separated and the quality of the product is increased by ensuring purification.



## PANJURLU BUĞDAY YIKAMA

SLOTTED WHEAT WASHING MACHINE





# TEKNİK ÇİZİM VE ÖZELLİKLER

## TECHNICAL DRAWING AND FEATURES

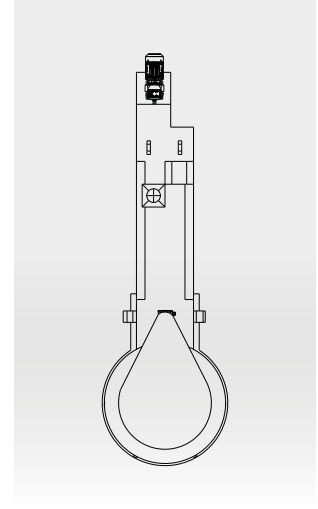
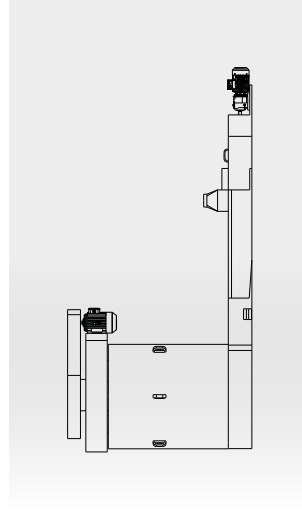
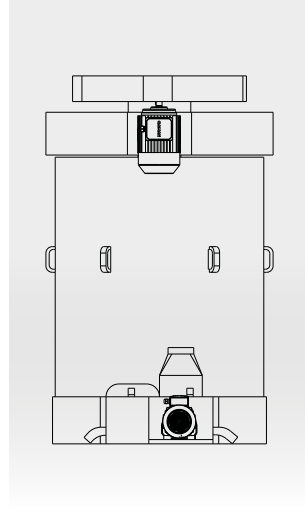
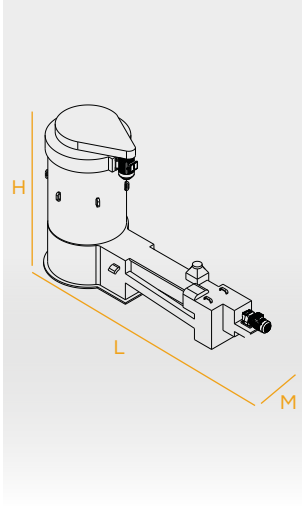

www.toprakcilarmakina.com

MODEL MODEL	MOTOR GÜCÜ MOTOR POWER	KURUTMA TİPİ DRYING TYPE	GÖVDE YAPISI BODY STRUCTURE	KAPASİTE CAPACITY	M-L-H
TM-BYM50	Yıkama (Washing):1,1kW Kurutma (Drying):7,5kW	Panjurlu 6 palet 6-blade louver	CR-NI	5000Kg/h	M: 1200 <sup>mm</sup> L: 4000 <sup>mm</sup> H: 2100 <sup>mm</sup>
TM-BYM100	Yıkama (Washing):1,1kW Kurutma (Drying):15kW	Panjurlu 6 palet 6-blade louver	CR-NI	10000Kg/h	M: 1500 <sup>mm</sup> L: 4200 <sup>mm</sup> H: 2100 <sup>mm</sup>



### TR

Panjurlu yıkama makinesi, suyla karıştırılmış buğdayın, panjurlu bir yapının içinden geçerek temizlenmesini sağlar. Panjurlar, suyun buğdayla etkili bir şekilde temas etmesini sağlayarak kirlerin ayrılmasına yardımcı olur. Su ile uzun süreli etkileşim ve panjurların tasarımı, temizleme işlemini daha verimli hale getirir. Bu makineler, özellikle nazik buğday türlerinin temizlenmesi için uygundur ve hassas temizlik sağlar.

### EN

The slotted washing machine ensures the cleaning of wheat by pushing it through a slotted structure together with water. The slots allow the water to effectively contact the wheat, helping to separate impurities. The prolonged interaction with water and the design of the slots make the cleaning process more efficient. These machines are particularly suitable for cleaning delicate wheat varieties and provide gentle cleaning.

INDUSTRIAL BULGUR MACHINES

Since 1985  
**TÖPRAKÇILAR**  
MAKİNA SANAYİ VE TİC. LTD. ŞTİ



**HELEZONLU BUĞDAY YIKAMA**

**SPIRAL WHEAT WASHING MACHINE**

# TEKNİK ÇİZİM VE ÖZELLİKLER

## TECHNICAL DRAWING AND FEATURES

www.toprakcilarmakina.com

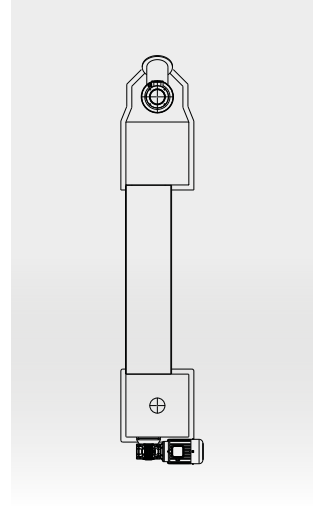
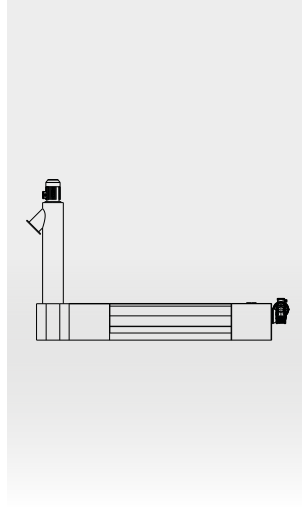
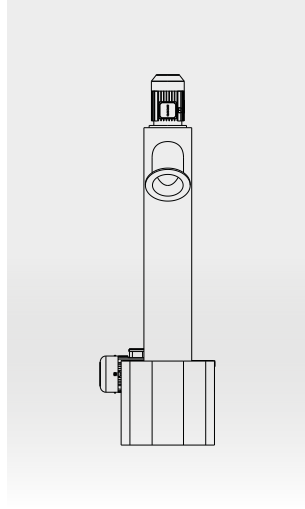
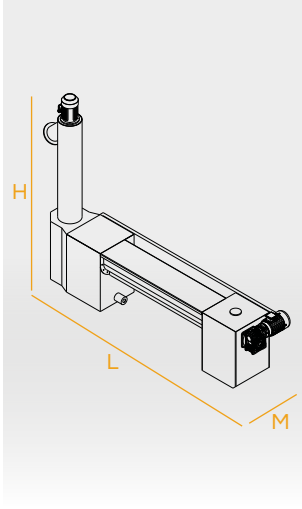

MODEL MODEL	MOTOR GÜCÜ MOTOR POWER	KURUTMA TİPİ DRYING TYPE	GÖVDE YAPISI BODY STRUCTURE	KAPASİTE CAPACITY	M-L-H
TM-HBYS	Yıkama (Washing):1,1kW Kurutma (Drying):2,2kW	Helezonlu Screw conveyor	Krom CR-NI	2500Kg/h	M: 600 <sup>mm</sup> L: 3500 <sup>mm</sup> H: 2000 <sup>mm</sup>



### TR

Helezonlu yıkama makinesi, dönen bir helezon miliyle buğdayı su içinde taşır. Bu hareket, buğdayın dönerken kirlerden arındırılmasını sağlar. Helezonlu makineler, hızlı çalışarak büyük miktarda buğdayı kısa sürede temizler. Bu makineler, büyük ölçekli üretimlerde yüksek kapasite gereksinimlerini karşılamak için ideal çözümler sunar.

### EN

The spiral washing machine carries the wheat in water with a rotating spiral shaft. This movement ensures that the wheat is cleaned of dirt as it rotates. Spiral machines work quickly and clean large amounts of wheat in a short time. These machines offer ideal solutions to meet high capacity requirements in large-scale production.



## PİŞİRME KAZANI

COOKING TANK

# TEKNİK ÇİZİM VE ÖZELLİKLER

## TECHNICAL DRAWING AND FEATURES

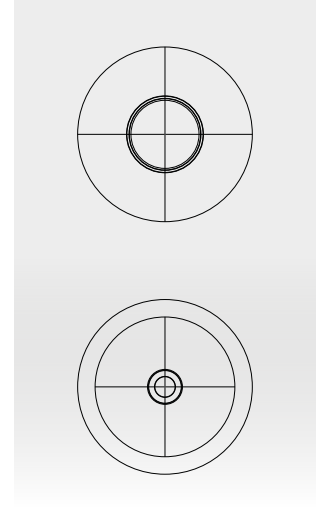
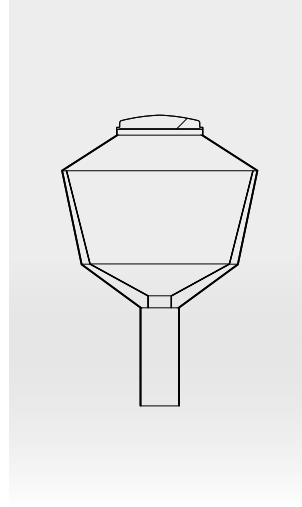
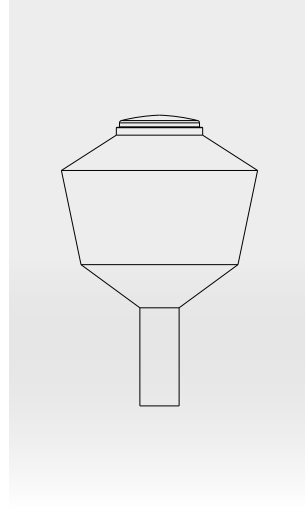
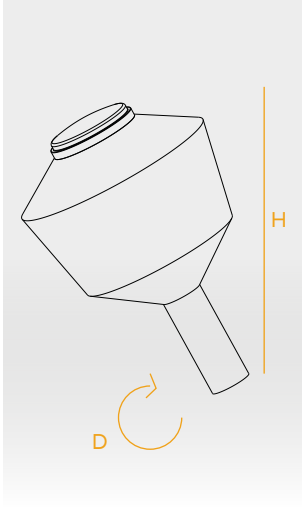

www.toprakcilarmakina.com

MODEL MODEL	KAYNATMA TİPİ BOILING TYPE	GÖVDE YAPISI BODY STRUCTURE	KONTROL SİSTEMİ CONTROL SYSTEM	KAPASİTE CAPACITY	D-H
TM-CPK10	Brülörlü Burner	AISI 304	Manüel Manual	1250Kg/h	D: 1750 <sup>mm</sup> H: 3750 <sup>mm</sup>
TM-CPK25	Brülörlü Burner	AISI 304	Otomasyon sistemi Automation system	2500Kg/h	D: 2250 <sup>mm</sup> H: 4500 <sup>mm</sup>
TM-CPK25S	Stoker	AISI 304	Manüel Manual	2500Kg/h	D: 2250 <sup>mm</sup> H: 4500 <sup>mm</sup>
TM-CPK50	Brülörlü Burner	AISI 304	Otomasyon sistemi Automation system	5000Kg/h	D: 3250 <sup>mm</sup> H: 5000 <sup>mm</sup>



### TR

Piştirme kazanı, bulgur üretiminde buğdayı eşit ve tutarlı bir şekilde pişirmek için kullanılır. Paslanmaz çelikten üretilen kazanlar, hijyenik koşulları koruyarak buğdayı hassas sıcaklıklarda pişirir. Buğday, kontrollü bir su ve buhar kombinasyonu ile pişirilir, böylece her tanenin eşit şekilde işlenmesi sağlanır. Bu işlem, buğdayın nişasta yapısını değiştirerek kurutma ve öğütme işlemleri için ideal hale getirir.

### EN

The cooking tank is used to cook wheat evenly and consistently in bulgur production. A stainless-steel tank cooks wheat at precise temperatures while maintaining hygienic conditions. Wheat is cooked with a controlled combination of water and steam, ensuring that each grain is processed equally. This process changes the starch structure of the wheat, making it ideal for drying and milling processes.

INDUSTRIAL BULGUR MACHINES

Since 1985  
**TÖPRAKÇILAR**  
MAKİNA SANAYİ VE TİC. LTD. ŞTİ



**PIŞİRME ÜNİTESİ BUNKERİ**

WHEAT COOKING UNIT BUNKER

# TEKNİK ÇİZİM VE ÖZELLİKLER

## TECHNICAL DRAWING AND FEATURES

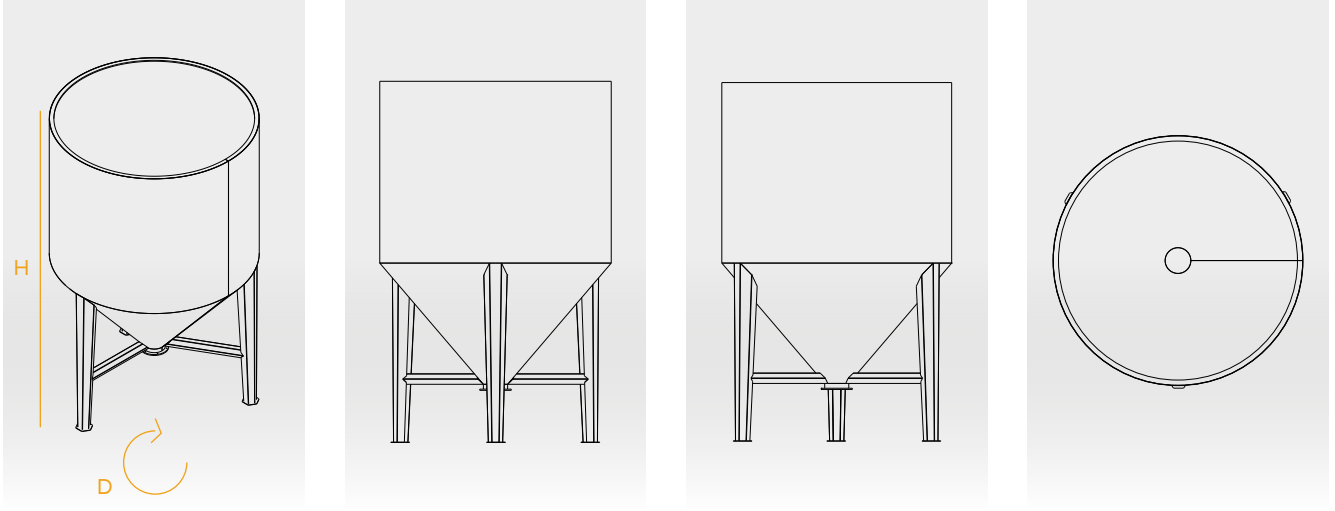

www.toprakcilarmakina.com

MODEL MODEL	TİPİ TYPE	GÖVDE YAPISI BODY STRUCTURE	AKTARMA TİPİ TRANSMISSION TYPE	KAPASİTE CAPACITY	D-H
TM-PUB25	Silindirik (Cylindrical) / Konik (Conical)	304 AISI SS	Helezonlu (Helical) / Doğal Akış (Natural Flow)	2500Kg/h	D: 1900mm H: 2800mm
TM-PUB30	Silindirik (Cylindrical) / Konik (Conical)	304 AISI SS	Helezonlu (Helical) / Doğal Akış (Natural Flow)	3000Kg/h	D: 1900mm H: 3200mm
TM-PUB50	Silindirik (Cylindrical) / Konik (Conical)	304 AISI SS	Helezonlu (Helical) / Doğal Akış (Natural Flow)	5000Kg/h	D: 2400mm H: 3000mm
TM-PUB75	Silindirik (Cylindrical) / Konik (Conical)	304 AISI SS	Helezonlu (Helical) / Doğal Akış (Natural Flow)	7500Kg/h	D: 2800mm H: 3000mm



### TR

Ürün depolama ve bekletme istasyonları, bulgur tesisinin kapasitesine göre hacmi hesaplanarak silindirik konik yapıda tasarlanırlar. Küf ve mantar oluşumlarını engellemek için özel açılar ve ölçülerle üretilir. Bu istasyonlar, ürünlerin kalitesini koruyarak uzun süreli depolama imkanı sağlar. Hijyenik koşulları yüksek tutarak, ürünlerin güvenli bir şekilde bekletilmesini ve üretim süreçlerinin kesintisiz ilerlemesini sağlar.

### EN

Product storage and waiting stations are designed in a cylindrical-conical structure by precisely calculating the volume according to the capacity of the Bulgur facility. They are produced with special angles and dimensions to prevent mold and fungus formation. These stations provide long-term storage opportunities by preserving the quality of the products. By maintaining hygienic conditions, they ensure safe storage of the products and a continuous production process.



**ÖN KURUTMA VAKUMU**

PRE-DRYING VACUUM



# TEKNİK ÇİZİM VE ÖZELLİKLER

## TECHNICAL DRAWING AND FEATURES

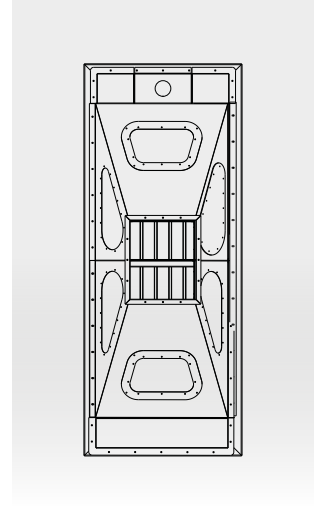
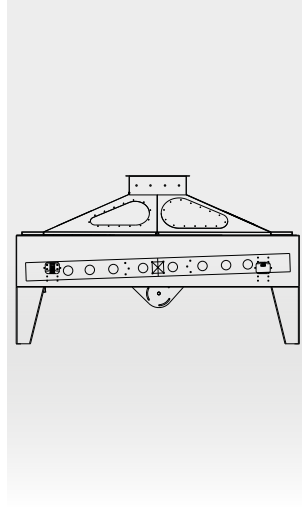
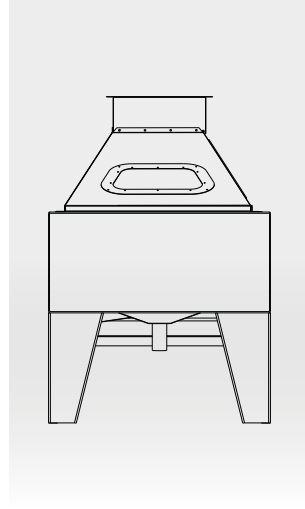
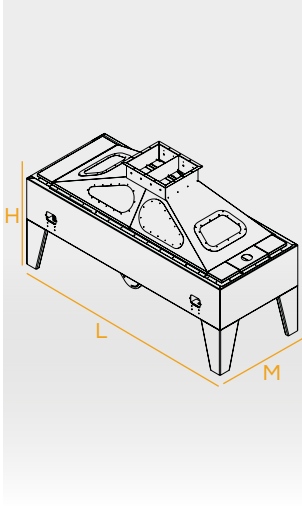

MODEL MODEL	MOTOR GÜCÜ MOTOR POWER	TİPİ TYPE	GÖVDE YAPISI BODY STRUCTURE	KAPASİTE CAPACITY	M-L-H
TM-OKV10	1,1kW	Soğutma kule tipi Cooling tower type	AISI304	1250Kg/h	M: 1200mm L: 3000mm H: 1800mm
TM-OKV25	2x1,1kW	Akışkan yataklı Fluidized bed	AISI304	2500Kg/h	M: 1200mm L: 3000mm H: 1800mm
TM-OKV50	2x1,5kW	Akışkan yataklı Fluidized bed	AISI304	5000Kg/h	M: 1200mm L: 4000mm H: 1800mm



### TR

Vakumlu kurutma makinesi, pişmiş bulgurun nem oranını azaltarak kurutma sürecini hızlandırır ve ürün kalitesini artırır. Düşük basınç ortamı oluşturarak, bulgur tanelerindeki nemin buharlaşmasını kolaylaştırır. Buharlaşan nem, vakum sistemi içinde yoğunlaşarak dışarı atılır. Bu işlem, üretim verimliliğini artırırken, bulgurun yüksek kalite standartlarına uygun olmasını sağlar.

### EN

A pre-drying vacuum drying machine reduces the moisture content of cooked bulgur, accelerating the main drying process and improving product quality. Creating a low-pressure environment facilitates the evaporation of moisture from the bulgur grains. The evaporated moisture condenses within the vacuum system and is expelled. This process enhances production efficiency and ensures that the bulgur meets high-quality standards.

INDUSTRIAL BULGUR MACHINES

Since 1985  
**TOPRAKÇILAR**  
MAKİNA SANAYİ VE TİC. LTD. ŞTİ



**KURUTMA KULESİ**

MAIN DRYING TOWER

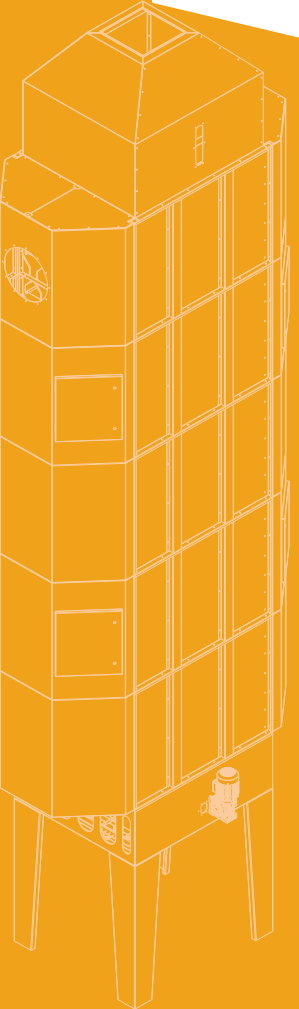

# TEKNİK ÇİZİM VE ÖZELLİKLER

## TECHNICAL DRAWING AND FEATURES

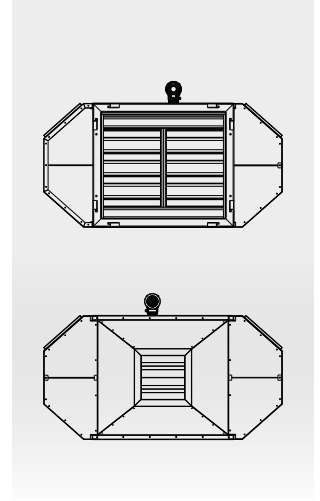
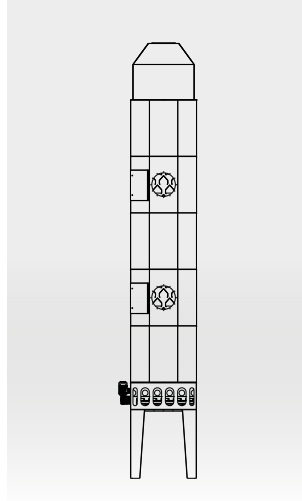
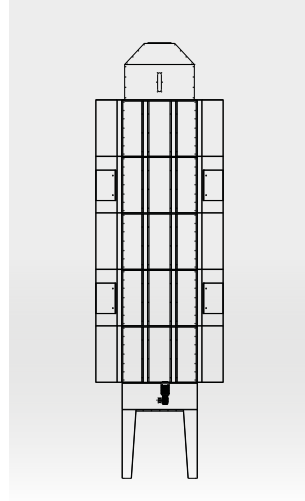
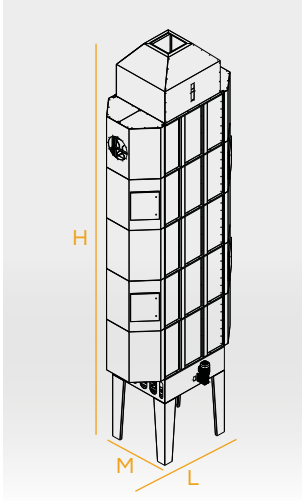

www.toprakcilarmakina.com

MODEL MODEL	MOTOR GÜCÜ MOTOR POWER	PASA ADEDİ MODULE NUMBER	ISI KAYNAĞI HEAT SOURCE	KAPASİTE CAPACITY	M-L-H
<b>TM-KK10</b>	1,1kW	9 Pasa / Module 3500-1900-1200	Termoblok Thermoblock	1250Kg/h	<b>M: 3500mm</b> <b>L: 1900mm</b> <b>H:13770mm</b>
<b>TM-BKK10</b>	1,1kW	9 Pasa / Module 3500-1900-1200	Buharlı Steamy	1250Kg/h	<b>M: 3500mm</b> <b>L: 1900mm</b> <b>H:13770mm</b>
<b>TM-KK25</b>	1,1kW	15 Pasa / Module 3500-1900-1200	Termoblok Thermoblock	2500Kg/h	<b>M: 3500mm</b> <b>L: 1900mm</b> <b>H:20970mm</b>
<b>TM-BKK25</b>	1,1kW	15 Pasa / Module 3500-1900-1200	Buharlı Steamy	2500Kg/h	<b>M: 3500mm</b> <b>L: 1900mm</b> <b>H:20970mm</b>
<b>TM-KK50</b>	1,5kW	24 Pasa / Module 3500-1900-1200	Termoblok Thermoblock	5000Kg/h	<b>M: 3500mm</b> <b>L: 1900mm</b> <b>H:31770mm</b>
<b>TM-BKK50</b>	1,5kW	24 Pasa / Module 3500-1900-1200	Buharlı Steamy	5000Kg/h	<b>M: 3500mm</b> <b>L: 1900mm</b> <b>H:31770mm</b>



### TR

Toprakçılar Makina'nın üretmekte olduğu kurutma kulesi, granül ürünlerin nemini hassas seviyelere düşürmek için tasarlanmıştır. Serpantin hava akışı ve modüler yapısı, homojen kurutma sağlarken küf, mantar ve kötü kokuları önler. Enerji tasarruflu bu sistem, yüksek performans sunarken operasyonel maliyetleri azaltır. Uluslararası standartlara uygun üretimiyle, tarımsal ürünlerde kalite ve sürdürülebilirlik sağlar.

### EN

The drying tower produced by Toprakçılar Makina is designed to reduce the moisture of granular products to precise levels. Serpentine air flow and modular structure prevent mold, fungus and bad odours while providing homogeneous drying. This energy-saving system reduces operational costs while offering high performance. With its production in accordance with international standards, it provides quality and sustainability in agricultural products.



## TAŞLI KABUK SOYMA

STONE PEELING MACHINE

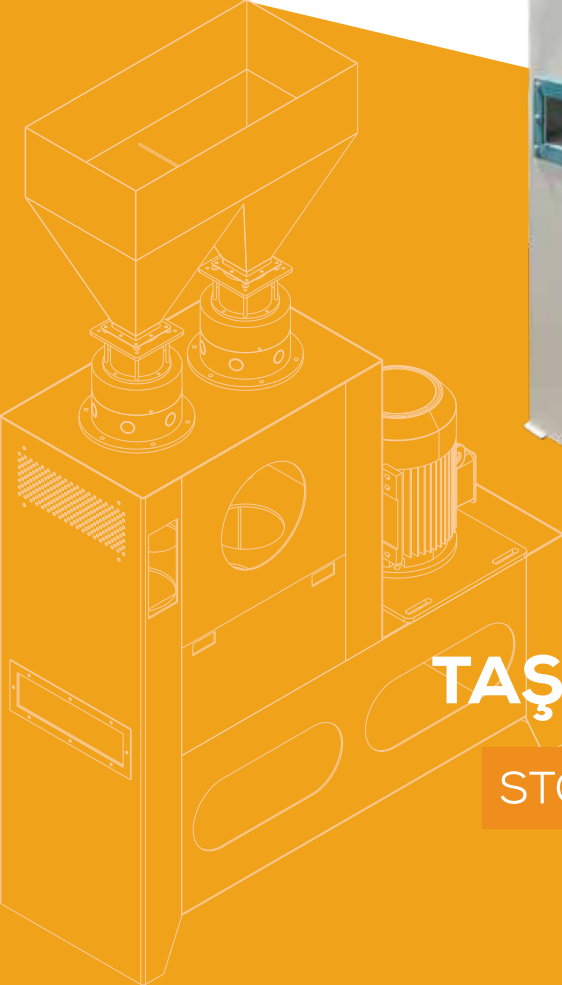

# TEKNİK ÇİZİM VE ÖZELLİKLER

## TECHNICAL DRAWING AND FEATURES

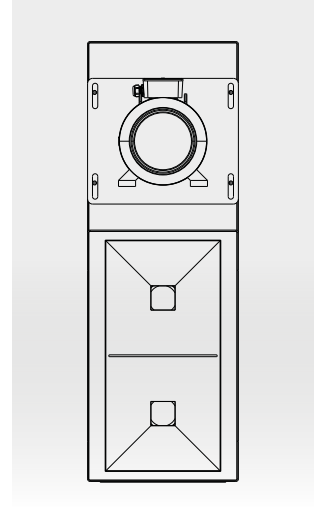
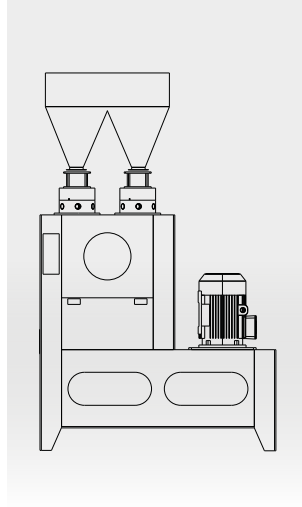
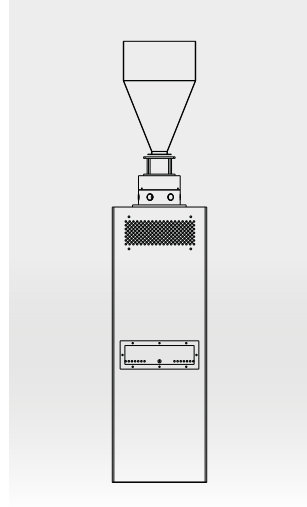
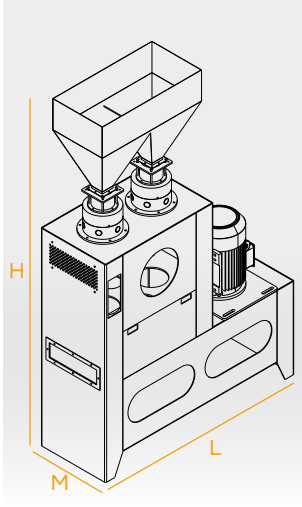

MODEL MODEL	MOTOR GÜCÜ MOTOR POWER	TÜRBİN TURBINE	SOYMA TİPİ PEELING TYPE	KAPASİTE CAPACITY	M-L-H
TM-TKS5	18,5kW	Tek türbin Single turbine	Taşlı Rocky	500Kg/h	M: 600 <sup>mm</sup> L: 1350 <sup>mm</sup> H: 2800 <sup>mm</sup>
TM-TKS10	30kW	Çift türbin Double turbine	Taşlı Rocky	1250Kg/h	M: 600 <sup>mm</sup> L: 1750 <sup>mm</sup> H: 2800 <sup>mm</sup>



### TR

Taşlı kabuk soyma makinesi, aşındırıcı taş diskleri kullanarak ürünün dış katmanını soyar. Bu işlem, ürünün temizliğini, işlenebilirliğini ve nihai tüketim için görsel çekiciliğini artırır. Soyma işlemi, ürün mekanik bir aşındırma tekniği kullanılarak dönen aşındırıcı taş diskleri arasında taşınırken gerçekleştirilir.

### EN

A stone peeling machine removes the outer layer of a product using abrasive stone discs. This process enhances the product's cleanliness, suitability for further processing, and visual appeal for final consumption. The peeling action is carried out as the product is conveyed between rotating abrasive stone discs, employing a mechanical abrasion technique.



## PALETLİ KABUK SOYMA

PALLETIZED HUSK PEELER

# TEKNİK ÇİZİM VE ÖZELLİKLER

## TECHNICAL DRAWING AND FEATURES

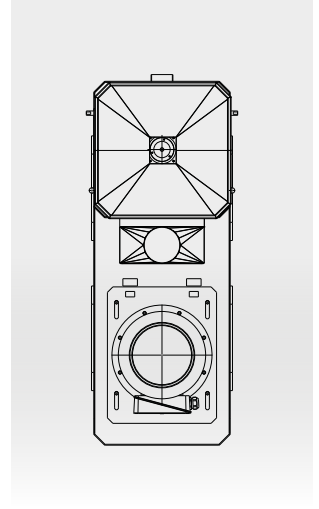
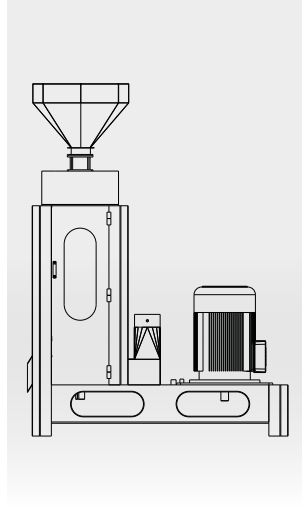
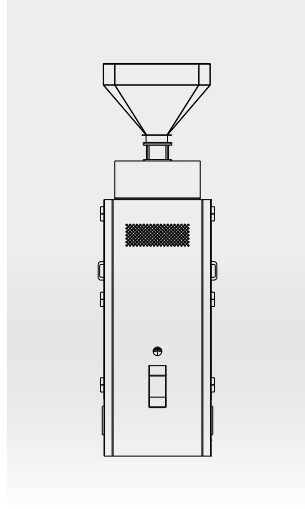
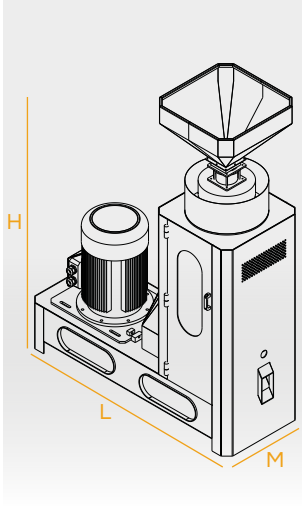

www.toprakcilmakina.com

MODEL MODEL	MOTOR GÜCÜ MOTOR POWER	TÜRBİN TURBINE	SOYMA TİPİ PEELING TYPE	KAPASİTE CAPACITY	M-L-H
TM-PKS10	30kW	Tek türbin Single turbine	Paletli Palletized	1000Kg/h	M: 700 <sup>mm</sup> L: 2000 <sup>mm</sup> H: 2700 <sup>mm</sup>
TM-PKS25	45kW	Tek türbin Single turbine	Paletli Palletized	2500Kg/h	M: 1200 <sup>mm</sup> L: 2000 <sup>mm</sup> H: 2700 <sup>mm</sup>



### TR

Paletli kabuk soyma makineleri, buğdayın kabuklarını soyma ve temizleme işleminde yüksek verimlilik sağlar. Bu makineler, taşlar ve aşındırıcı yüzeyler yerine paletli bir sistem kullanarak çalışır. Ürünler, paletler üzerinde ilerlerken sürtünme ve basınç etkisiyle kabuklarından ayrılır. Paletli sistem, ürünlerin eşit şekilde soyulmasını sağlar ve tanelerin kırılma riskini azaltır.

### EN

Palletized Husk Peeling machines offer high efficiency in peeling and cleaning wheat. Instead of using stones or abrasive surfaces, these machines utilize a pallet system. As the wheat moves across the pallets, friction and pressure effectively separate the husks from the grains. This system ensures even peeling and significantly reduces the risk of grain breakage, enhancing both the quality and yield of the final product.

INDUSTRIAL BULGUR MACHINES

Since 1985  
**TÖPRAKÇILAR**  
MAKİNA SANAYİ VE TİC. LTD. ŞTİ



**TAVLAMA HELEZONU**

MOISTENING SCREW





# TEKNİK ÇİZİM VE ÖZELLİKLER

## TECHNICAL DRAWING AND FEATURES

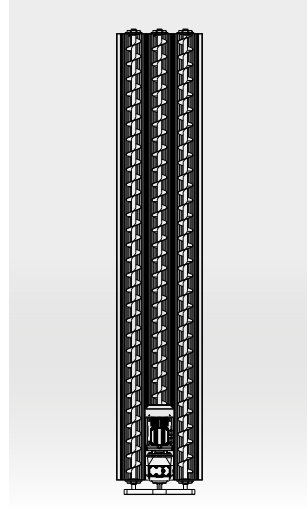
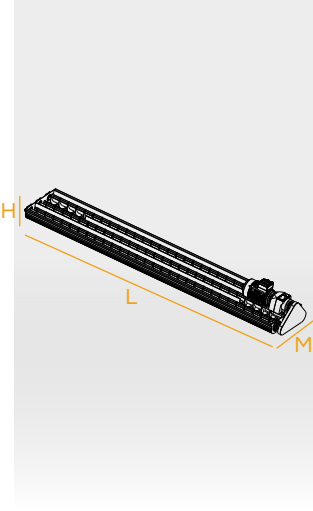

www.toprakcilarmakina.com

MODEL MODEL	MOTOR GÜCÜ MOTOR POWER	HELEZON ÇAPI ve KADEME SCREW DIAMETER and STEP	OTOMATİK TAVLAMA AUTOMATIC ANNEALING	KAPASİTE CAPACITY	M-L-H
TM-TH10	1,1kW	ø150 <sup>mm</sup> - 2	Yok N/A	1000kg/h	M: 400 <sup>mm</sup> L: 3300 <sup>mm</sup> H: 1250 <sup>mm</sup>
TM-TH20	1,5kW	ø150 <sup>mm</sup> - 3	Var Available	2000kg/h	M: 550 <sup>mm</sup> L: 3300 <sup>mm</sup> H: 1250 <sup>mm</sup>
TM-TH30	2,2kW	ø180 <sup>mm</sup> - 3	Var Available	3000kg/h	M: 640 <sup>mm</sup> L: 3300 <sup>mm</sup> H: 1250 <sup>mm</sup>
TM-TH50	3kW	ø200 <sup>mm</sup> - 3	Var Available	5000kg/h	M: 700 <sup>mm</sup> L: 3300 <sup>mm</sup> H: 1250 <sup>mm</sup>



### TR

Kurutulduktan sonra bulgurun tipik nem içeriği yaklaşık %10 ila %12'dir. Tavlama Helezonu, kullanılan buğday türüne bağlı olarak nem içeriğini %15 ila %24 arasına çıkarmak için kullanılır. Bu aşama, nemin homojen bir şekilde dağılmasını sağlamak için dikkatlice kontrol edilir. Tavlama süreci, bulgurun doğal rengini korumada, istenen renk tonuna ulaşmada, israfı azaltmada ve lezzeti dengelemede önemli bir rol oynar.

### EN

The typical moisture content of the bulgur after drying is about 10% to 12%. The Humidification Screw is used to increase the moisture content up to between 15% and 24%, depending on the type of wheat being used. This stage is carefully controlled to ensure the moisture is distributed homogeneously. The humidification process plays a crucial role in preserving the natural colour of the bulgur, achieving the desired colour tone, reducing waste, and balancing the flavour.



# OTOMATİK TAVLAMA MAKİNESİ

AUTOMATIC TEMPERING MACHINE

# TEKNİK ÇİZİM VE ÖZELLİKLER

## TECHNICAL DRAWING AND FEATURES

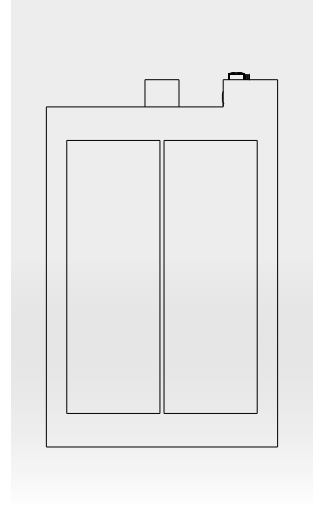
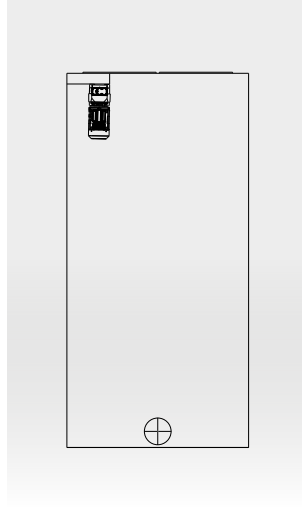
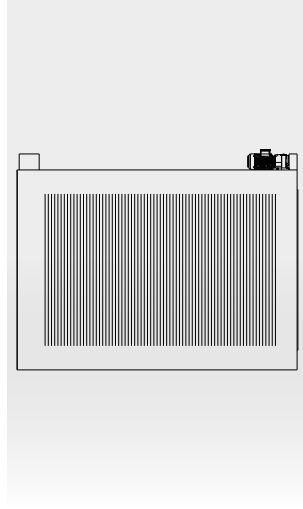
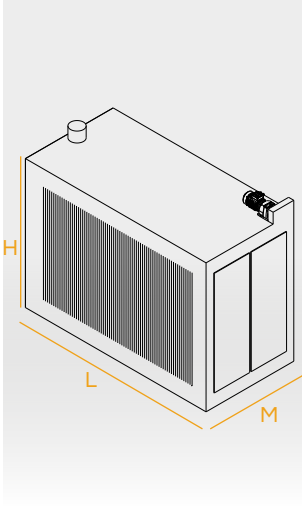

www.toprakcilarmakina.com

MODEL MODEL	MOTOR GÜCÜ MOTOR POWER	KAT SAYISI NUMBER of LAYERS	OTOMATİK DEBİMETRE AUTOMATIC FLOWMETER	KAPASİTE CAPACITY	M-L-H
TM-OTM25	4kW	2x6 Kat döner sistem 2x6 Layer rotary system	Var Available	2500kg/h	M: 1250mm L: 3500mm H: 2700mm
TM-OTM50	7,5kW	3x6 Kat döner sistem 3x6 Layer rotary system	Var Available	5000kg/h	M: 1750mm L: 3500mm H: 2700mm



### TR

Tavlama makinesi, bulgurun nem oranını artırmak için kullanılan bir ekipmandır. Bu makine, bulgurun dışındaki kabuğun (kepeğin) daha kolay soyulabilmesi için ürünü belirli bir nem seviyesine getirir. Ayrıca, soyulmuş bulgurdaki fire oranını azaltır ve istenilen sarı rengin elde edilmesini sağlar. Bu işlem, yüksek kaliteli bulgur üretimi için önemlidir.

### EN

The moistening machine is an equipment used to increase the moisture content of bulgur. This machine brings the product to a certain moisture level so that the outer shell (bran) of the bulgur can be peeled easily. It also reduces the waste rate in the peeled bulgur and ensures that the desired yellow colour is obtained. This process is crucial for high-quality bulgur production.



## DİSKLİ DEĞİRMEN

DISC MILL

# TEKNİK ÇİZİM VE ÖZELLİKLER

## TECHNICAL DRAWING AND FEATURES

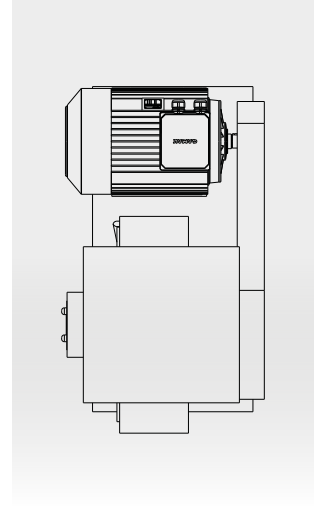
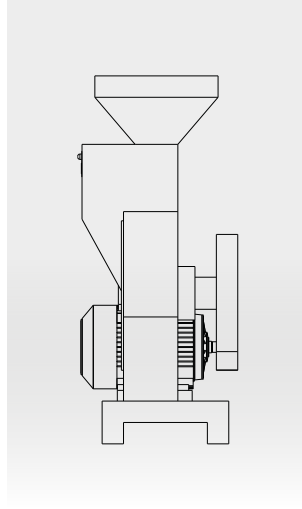
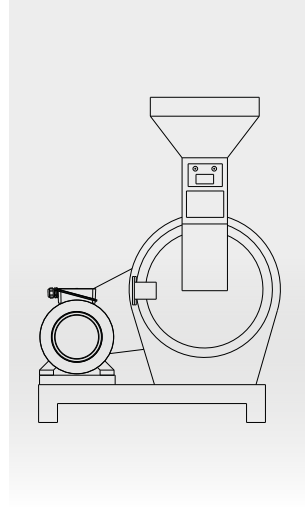
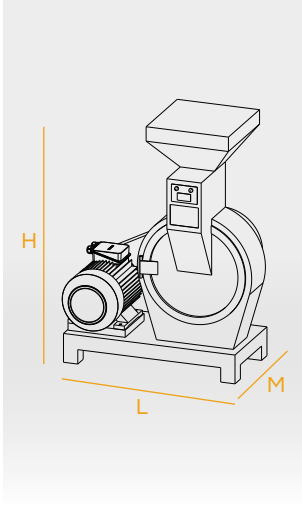

www.toprakcilarmakina.com

MODEL MODEL	MOTOR GÜCÜ MOTOR POWER	DİSK ÇAPI DISC DIAMETER	AKTARMA TİPİ TRANSMISSION TYPE	KAPASİTE CAPACITY	M-L-H
HT-50DK	18,5kW	ø500mm	Kayış / Kasnak Belt / Pulley	500kg/h	M: 600mm L: 1200mm H: 1700mm
HT-80DK	37kW	ø800mm	Kayış / Kasnak Belt / Pulley	1250kg/h	M: 1100mm L: 1500mm H: 2100mm



### TR

Bulgur üretiminde kullanılan diskli değirmen, buğday tanelerini iki döner disk arasında sıkıştırarak öğütür. Diskler arasındaki mesafe ayarlanabilir, bu sayede öğütme derecesi kontrol edilir. Bu makine, homojen ve kaliteli bulgular elde edilmesini sağlar. Ayrıca, yüksek verimlilikle hızlı bir öğütme işlemi sunarak büyük ölçekli üretimlerde verimliliği artırır.

### EN

The disc mill grinds wheat grains by squeezing them between two rotating discs. The adjustable distance between the discs allows for precise control over the degree of grinding, ensuring the production of homogeneous and high-quality bulgur. This machine enhances efficiency in large-scale production by delivering a fast and highly efficient grinding process, making it essential for optimizing both quality and productivity.



## TAŞ DEĞİRMEN

STONE MILL

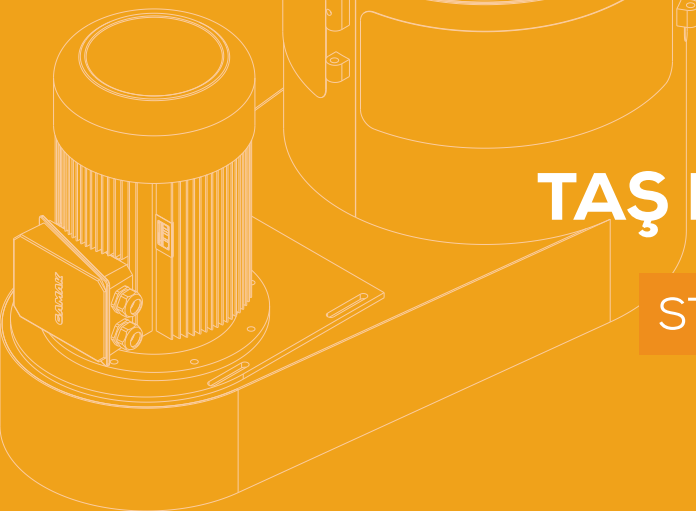

# TEKNİK ÇİZİM VE ÖZELLİKLER

## TECHNICAL DRAWING AND FEATURES

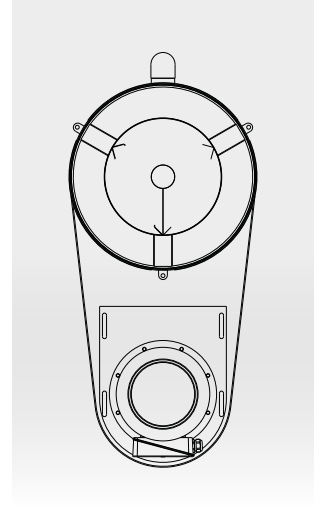
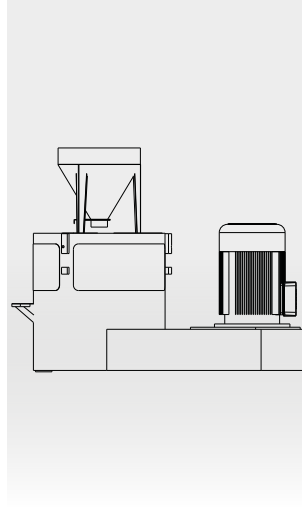
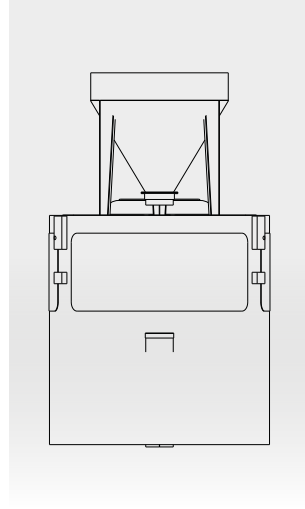
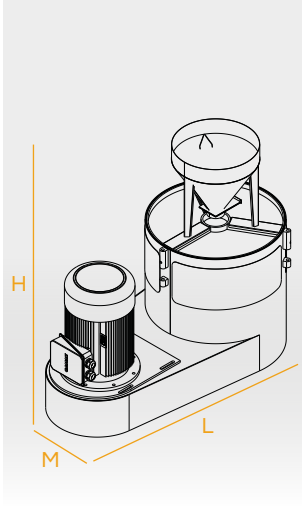

www.toprakcilarmakina.com

MODEL MODEL	MOTOR GÜCÜ MOTOR POWER	TAŞ ÇAPI STONE DIAMETER	KULLANIM AMACI PURPOSE OF USE	KAPASİTE CAPACITY	M-L-H
TM-TD40	11kW	ø400 <sup>mm</sup>	Bulgur	150-250Kg/h	M: 575 <sup>mm</sup> L: 1250 <sup>mm</sup> H: 1100 <sup>mm</sup>
TM-TD80	37kW	ø800 <sup>mm</sup>	Bulgur	350-550Kg/h	M: 1000 <sup>mm</sup> L: 2000 <sup>mm</sup> H: 1600 <sup>mm</sup>



### TR

Taş değirmen, iki büyük taş arasında buğdayı öğütür ve taşlardaki dişli yapılar sayesinde buğday tanelerini parçalara ayırır. Taş değirmenlerin avantajı, düşük ısınma ile buğdayın doğal özelliklerinin korunması ve besin değerlerinin kaybolmamasıdır. Bu yöntem, özellikle doğal ve geleneksel üretimle üretilen bulgurlar için tercih edilir.

### EN

The stone mill produces bulgur by grinding wheat between two large stones and separating the wheat grains into pieces thanks to the toothed structures on the stones. The advantage of stone mills is that the natural characteristics and nutritional values of wheat are preserved due to low heating. The stone mill is especially preferred for bulgur produced with natural and traditional production process.



## TAŞLI UN DEĞİRMENİ

STONE FLOUR MILL



# TEKNİK ÇİZİM VE ÖZELLİKLER

## TECHNICAL DRAWING AND FEATURES

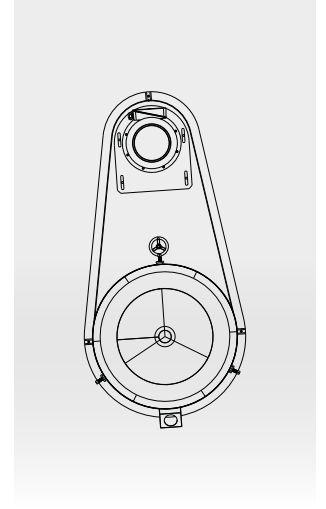
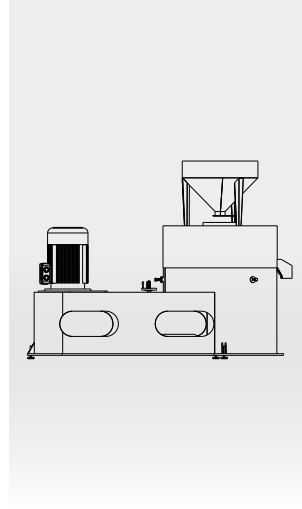
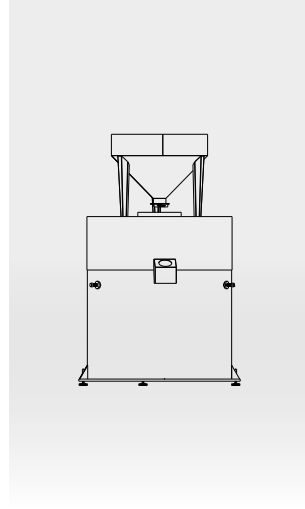
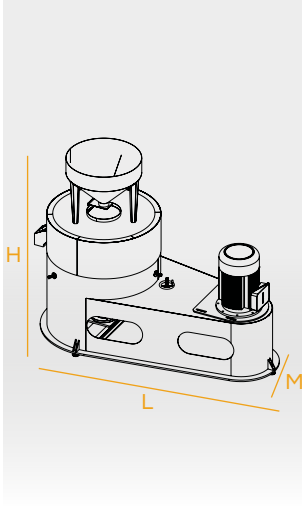

MODEL MODEL	MOTOR GÜCÜ MOTOR POWER	TAŞ ÇAPı STONE DIAMETER	KULLANIM AMACI PURPOSE OF USE	KAPASİTE CAPACITY	M-L-H
TM-UD120	37kW	ø1200 <sup>mm</sup>	Un Flour	400-500Kg/h	M: 1500 <sup>mm</sup> L: 3000 <sup>mm</sup> H: 2300 <sup>mm</sup>



### TR

Taş Un Değirmeni, tahılları iki taş disk arasında öğüterek ince un üretir. Bu geleneksel öğütme yöntemi, tahılların doğal besinlerini ve lezzetini koruyan nazik bir öğütme işlemi sağlar ve bu da onu ekme, kek ve diğer fırıncılık ürünlerinde kullanılan yüksek kaliteli un üretmek için ideal hale getirir. Ayrıca değirmen, kepek gibi yan ürünler üretmek için buğday kabuklarını ayırır.

### EN

The Stone Flour Mill produces fine flour by grinding grains between two stone discs. This traditional milling method ensures a gentle grinding process that preserves the natural nutrients and flavour of the grains, making it ideal for producing high-quality flour used in bread, cake, and other bakery products. Additionally, the mill separates the wheat hulls to produce by-products such as bran.



## BULGUR PARLATMA

BULGUR POLISHING

# TEKNİK ÇİZİM VE ÖZELLİKLER

## TECHNICAL DRAWING AND FEATURES

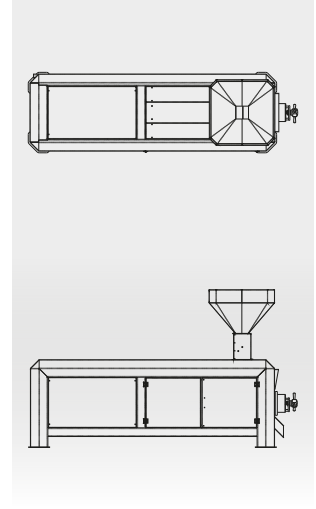
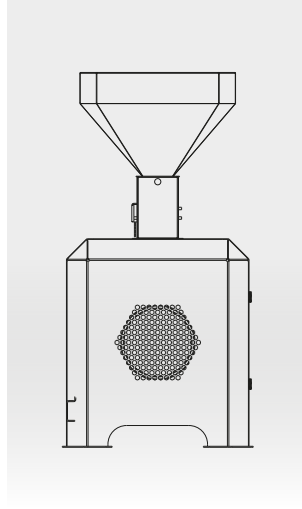
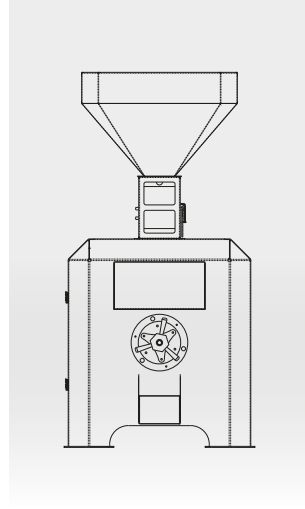
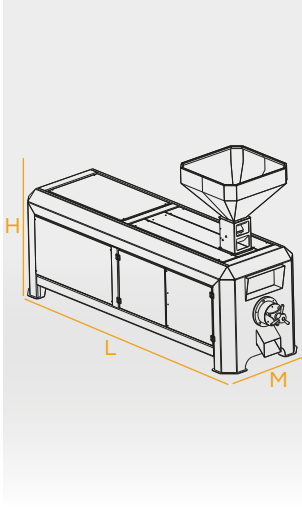

MODEL MODEL	MOTOR GÜCÜ MOTOR POWER	TAVLAMA SİSTEMİ HUMIDIFICATION SYSTEM	AKTARMA TİPİ TRANSFER TYPE	KAPASİTE CAPACITY	M-L-H
TM-BPM10	55kW	Otomatik Automatic	Kaplin aktarmalı With coupling	1250Kg/h	M: 900 <sup>mm</sup> L: 2800 <sup>mm</sup> H: 1800 <sup>mm</sup>
TM-BPM20	75kW	Otomatik Automatic	Kaplin aktarmalı With coupling	2000Kg/h	M: 900 <sup>mm</sup> L: 3000 <sup>mm</sup> H: 1800 <sup>mm</sup>
TM-BPM25	90kW	Otomatik Automatic	Kaplin aktarmalı With coupling	2500Kg/h	M: 900 <sup>mm</sup> L: 3200 <sup>mm</sup> H: 2000 <sup>mm</sup>



### TR

Bulgur parlatma makineleri, bulgur tanelerinin yüzeyini cilalayarak parlaklıklarını ve görsel çekiciliklerini artırır. Bu makineler, ince kabuklar ve toz gibi istenmeyen parçacıkları etkili bir şekilde temizler ve daha temiz, cilalı bir bulgur elde edilmesini sağlar. Daha düzgün bir yüzey ve yüksek kalite sunarak, bulgur parlatma makineleri ürünün genel kalitesini iyileştirir. Bu sayede, bulgurun pazar değeri artar.

### EN

Bulgur polishing machines polish the surface of bulgur grains, increasing their shiny visual appeal. These machines effectively remove unwanted particles, such as fine shells and dust, resulting in a cleaner, more polished bulgur. By providing a smoother surface and higher quality, bulgur polishing machines improve the overall quality of the product, thus increasing the market value of bulgur.



## KEPEK ALICI KONSANTRATÖR

BRAN-REMOVING CONCENTRATOR

# TEKNİK ÇİZİM VE ÖZELLİKLER

## TECHNICAL DRAWING AND FEATURES

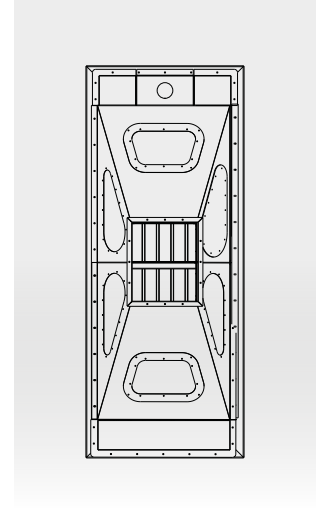
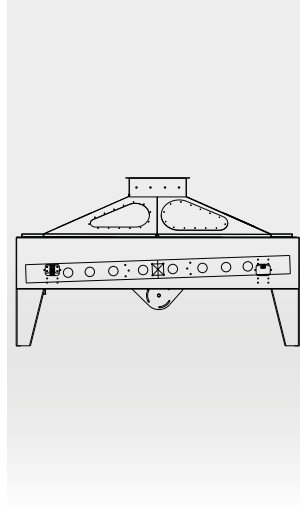
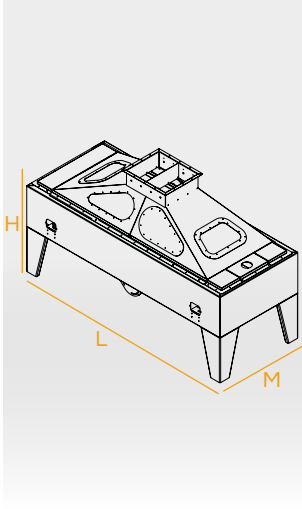

MODEL MODEL	MOTOR GÜCÜ MOTOR POWER	MOTOR TİPİ MOTOR TYPE	TİPİ TYPE	KAPASİTE CAPACITY	M-L-H
TM-KAK25	2x1,1kW	Vibro motor Vibratory motor	Akışkan yataklı Fluidized bed	2500Kg/h	M: 1200 <sup>mm</sup> L: 3000 <sup>mm</sup> H: 1800 <sup>mm</sup>
TM-KAK50	2x1,5kW	Vibro motor Vibratory motor	Akışkan yataklı Fluidized bed	5000Kg/h	M: 1200 <sup>mm</sup> L: 4000 <sup>mm</sup> H: 1800 <sup>mm</sup>



### TR

Kepek alıcı konsantratörler, hava akımı kullanarak hafif kepekleri yukarı taşır, böylece daha ağır bulgur tanelerinden ayırır. Bu işlem, tanelerin yoğunluğuna göre gerçekleşir ve kepek ile bulgur arasındaki ağırlık farkına dayanır. Titreşimli yüzeyler, buğday tanelerinin ve kepeğin ayrılmasını kolaylaştırır. Sonuç olarak, bulgur taneleri ve kepek arasında etkin bir ayırım sağlanır.

### EN

Bran-removing concentrator uses air currents to lift the light bran to separate it from the heavier bulgur grains. This process is carried out according to the density of the grains and is based on the weight difference between the bran and bulgur. Vibrating surfaces facilitate the separation of wheat grains and bran. As a result, an effective separation is achieved between bulgur grains and bran.

INDUSTRIAL BULGUR MACHINES

Since 1985  
**TOPRAKÇILAR**  
MAKİNA SANAYİ VE TİC. LTD. ŞTİ



**NEM KONTROL KULESİ**

CONTROL DRYING TOWER

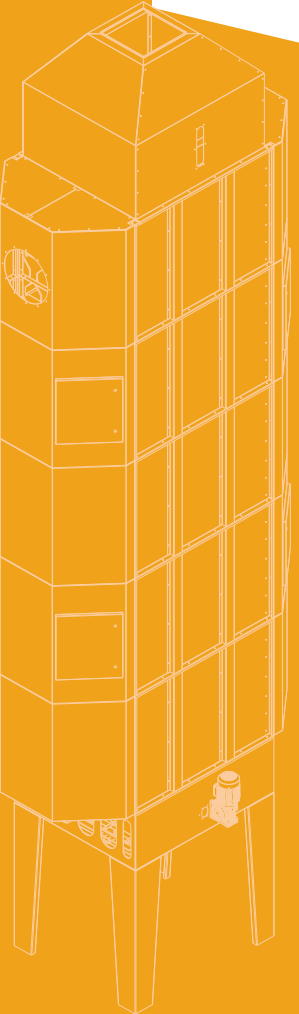

# TEKNİK ÇİZİM VE ÖZELLİKLER

## TECHNICAL DRAWING AND FEATURES

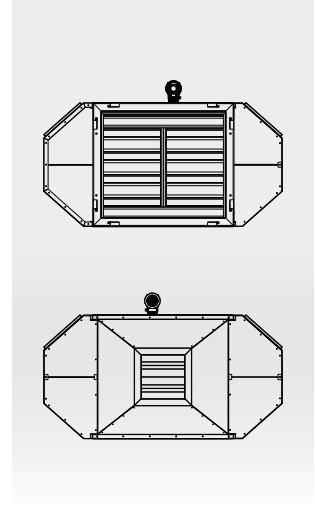
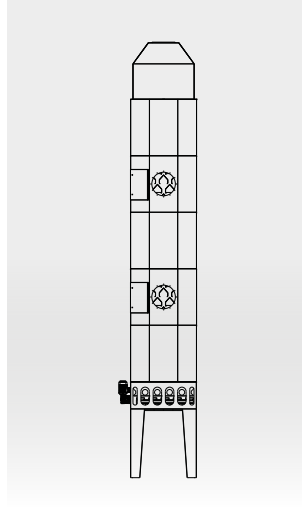
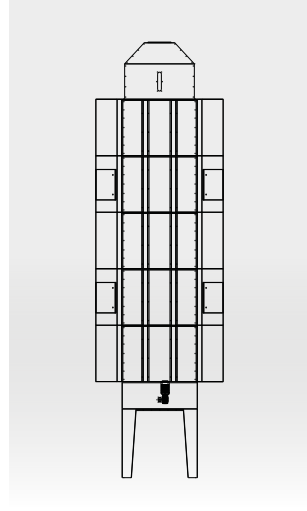
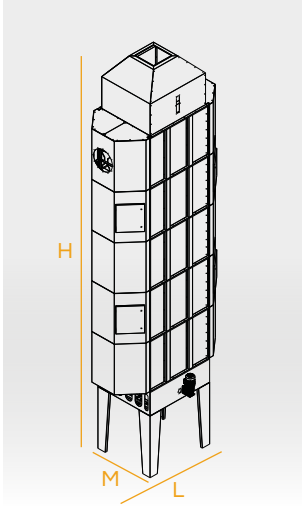

MODEL MODEL	MOTOR GÜCÜ MOTOR POWER	PASA ADEDİ MODULE NUMBER	KULLANIM AMACI PURPOSE OF USE	KAPASİTE CAPACITY	M-L-H
TM-NKK10	1,1kW	3 Pasa / Module 1400-2700-1200	Kurutma Drying	1250Kg/h	M: 1400mm L: 2700mm H: 4800mm
TM-NKK25	1,1kW	5 Pasa / Module 1400-2700-1200	Kurutma Drying	2500Kg/h	M: 1400mm L: 2700mm H: 7200mm
TM-NKK50	1,5kW	8 Pasa / Module 1400-2700-1200	Kurutma Drying	5000Kg/h	M: 1400mm L: 2700mm H: 10800mm
TM-NSK50	1,1kW	2 Pasa / Module 1400-2700-1200	Soğutma Cooling	5000Kg/h	M: 1400mm L: 2700mm H: 3600mm



### TR

Toprakçılar Makina'nın tasarlayıp üretmiş olduğu, Kontrol Kurutma Kulesi, serpantin hava akışı sistemi ve yarı modüler tasarımıyla her tanede eşit nem dağılımı sağlar. Bu tasarım, topaklanma, küf ve mantar oluşumunu önlerken ölü noktaları en aza indirerek kurutma sürecini optimize eder. Ürün kalitesini artıran kule, bozulmayı azaltır ve uluslararası hijyen standartlarına uygun güvenli bir kurutma ortamı sunar.

### EN

Toprakçılar Makina's designed and manufactured Control Drying Tower provides equal moisture distribution in each grain with its serpentine air-flow system and semi-modular design. This design prevents the formation of clumps, mold and fungus while optimizing the drying process by minimizing dead spots. The tower increases product quality, reduces deterioration and provides a safe drying environment that complies with international hygiene standards.

INDUSTRIAL BULGUR MACHINES

Since 1985  
**TOPRAKÇILAR**  
MAKİNA SANAYİ VE TİC. LTD. ŞTİ

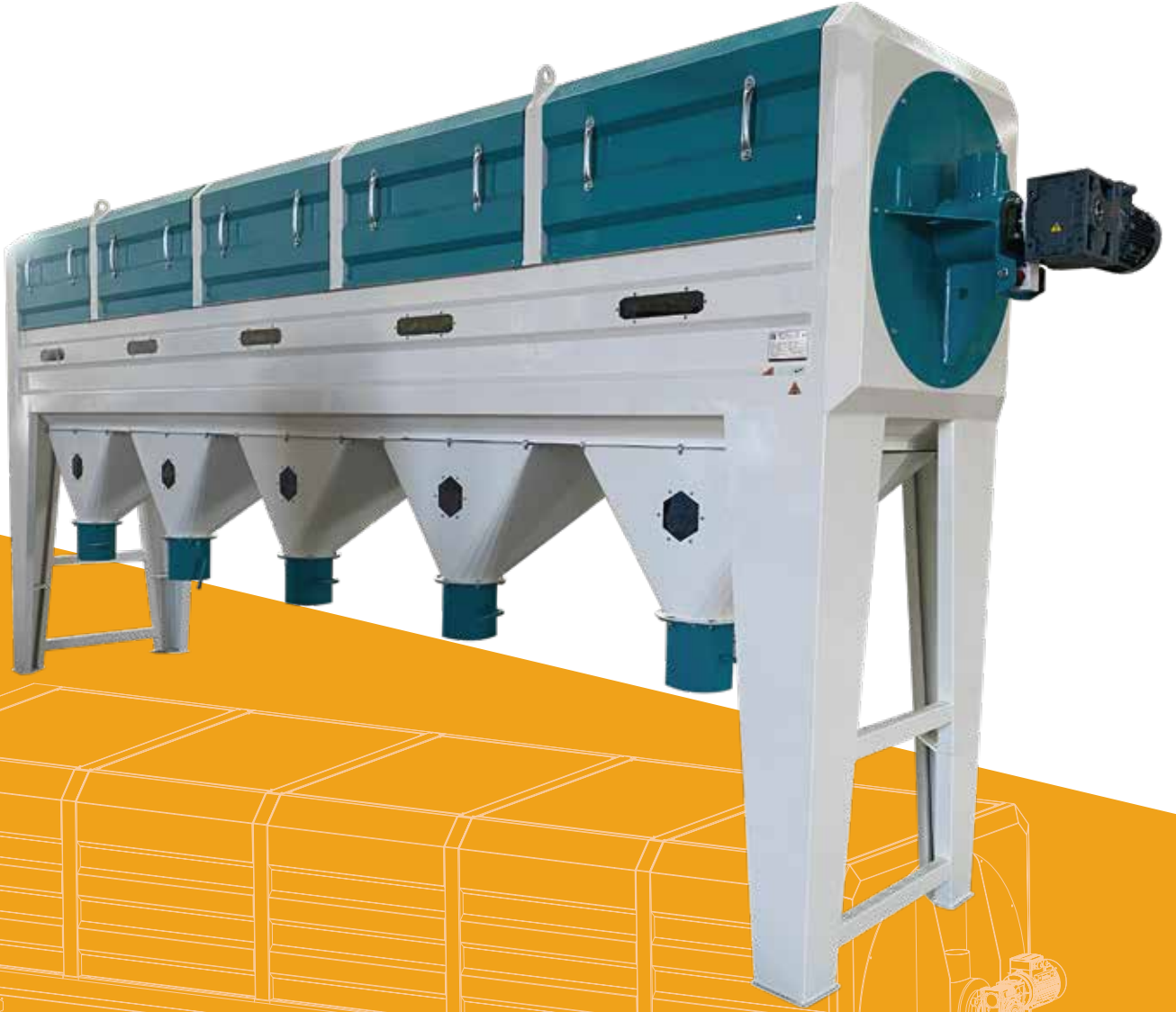

**SINIFLANDIRMA ELEĐİ**

CLASSIFICATION SIEVE



# TEKNİK ÇİZİM VE ÖZELLİKLER

## TECHNICAL DRAWING AND FEATURES

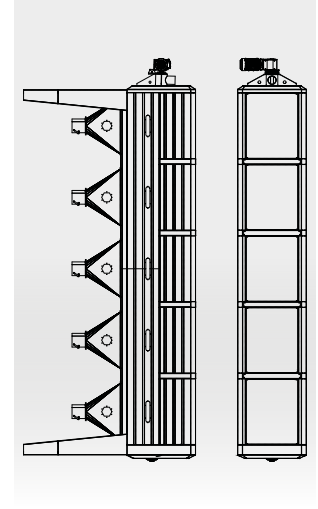
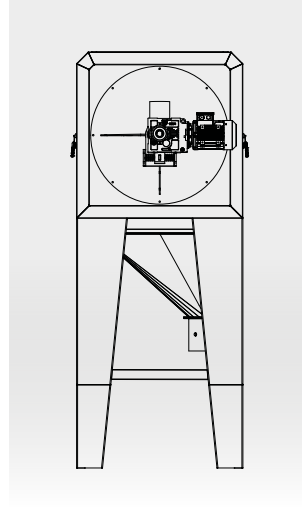
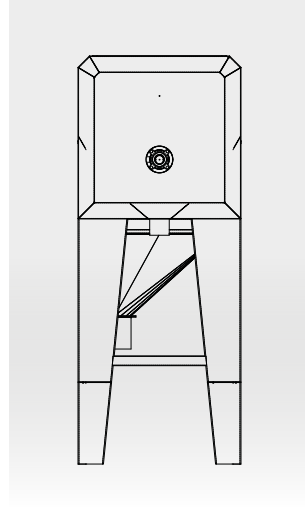
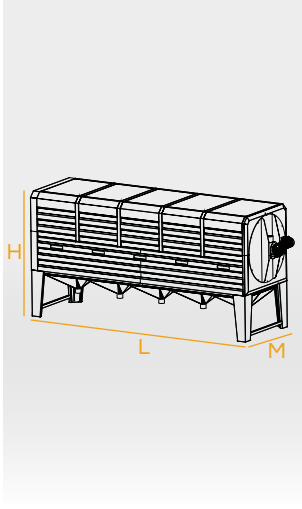

www.toprakcilarmakina.com

MODEL MODEL	MOTOR GÜCÜ MOTOR POWER	TİPİ TYPE	ELEK SAYISI SCREEN NUMBER	KAPASİTE CAPACITY	M-L-H
TM-SE10	2,2kW	Döner tip Rotary type	5	1250Kg/h	M: 1000mm L: 5400mm H: 2000mm
TM-SE25	4kW	Döner tip Rotary type	5	2500Kg/h	M: 1400mm L: 5400mm H: 2400mm
TM-SE50	5,5kW	Döner tip Rotary type	5	5000Kg/h	M: 1800mm L: 6200mm H: 2800mm

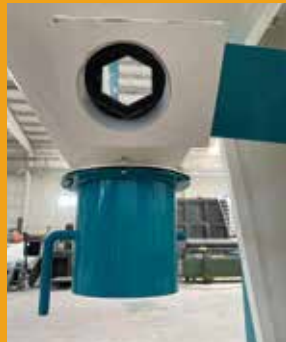

### TR

Sınıflandırma eleği, bulgur tanelerini boyutlarına göre ayıran önemli bir ekipmandır. Tasarlamış olduğumuz bu elek, üretim sürecinde verimliliği artırarak bulguru sınıflara ayırarak kalitenin tandardizasyonunu sağlar.

### EN

The classification sieve is an important piece of equipment that separates bulgur grains according to their size. This sieve that we designed increases efficiency in the production process and ensures standardization of quality by separating bulgur into classes.



## BAŞAK PATLATMA

WHEAT THRESHING MACHINE

# TEKNİK ÇİZİM VE ÖZELLİKLER

## TECHNICAL DRAWING AND FEATURES

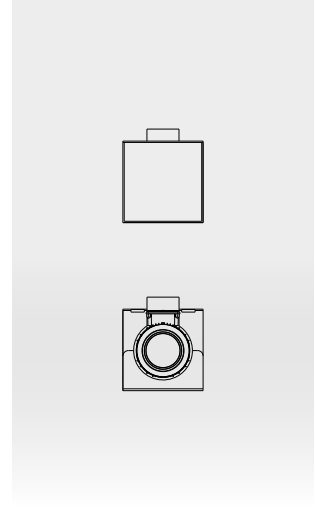
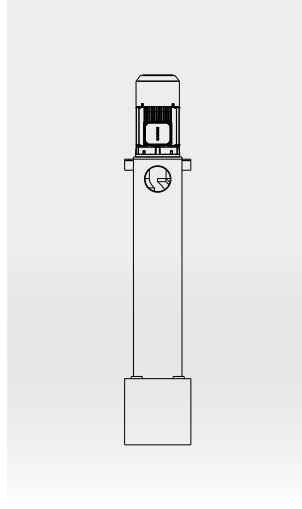
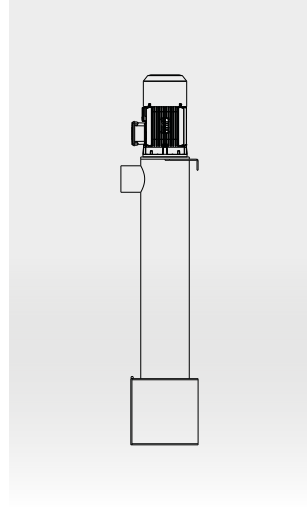
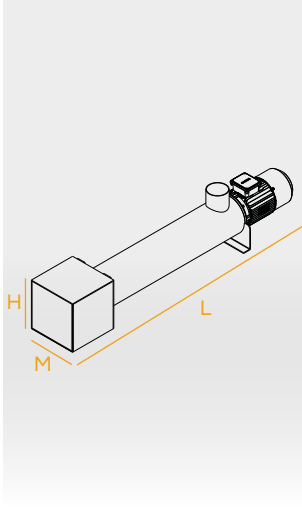

MODEL MODEL	MOTOR GÜCÜ MOTOR POWER	ÇAPA TİPİ ANCHOR TYPE	KAPASİTE CAPACITY	M-L-H
TM-BP20	2,2kW	Flanşlı-Kaynaklı Flanged-Welded	2000-3000kg/h	M: 300 <sup>mm</sup> L: 1600 <sup>mm</sup> H: 300 <sup>mm</sup>
TM-BP50	7,5kW	Flanşlı-Kaynaklı Flanged-Welded	5000-6000kg/h	M: 300 <sup>mm</sup> L: 1700 <sup>mm</sup> H: 300 <sup>mm</sup>



### TR

Başak patlatma makinesi, tahılları kabuklarından hassas bir şekilde ayırmak için buğday başlarını mekanik olarak işler. Bu makineler, genellikle bulgur ve un üretiminde kullanılır ve yüksek verimlilik ile hız sağlar. Ayarlanabilir ayarları sayesinde farklı buğday türlerine uyum sağlayarak optimum sonuçlar elde edilmesini mümkün kılar. Modern başak patlatma makineleri, enerji verimliliği sağlayarak üretim hattının performansını artırır.

### EN

The Wheat Thresher Machine mechanically processes wheat heads to precisely separate the grains from their shells. These machines are generally used in the production of bulgur and flour and provide high efficiency and speed. Thanks to its adjustable settings, it is possible to achieve optimum results by adapting to different types of wheat. Modern Wheat Threshing machines increase the performance of the production line by providing energy efficiency.

INDUSTRIAL BULGUR MACHINES

Since 1985  
**TÖPRAKÇILAR**  
MAKİNA SANAYİ VE TİC. LTD. ŞTİ



**SICAK HAVA TERMOBLOĞU**

HOT AIR THERMOBLOCK

# TEKNİK ÇİZİM VE ÖZELLİKLER

## TECHNICAL DRAWING AND FEATURES

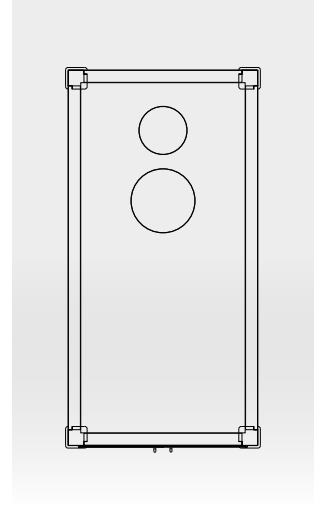
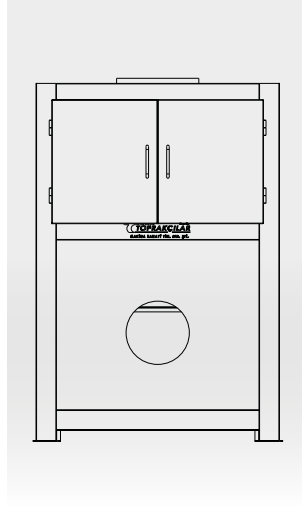
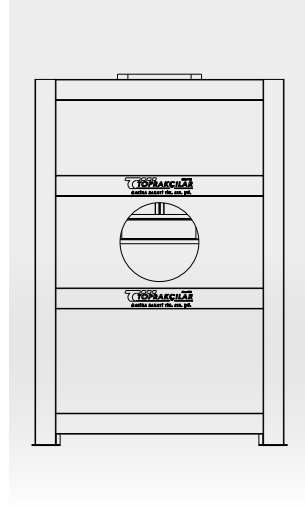
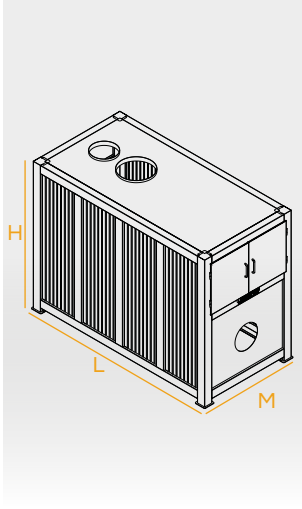

MODEL MODEL	YAKIT TİPİ FUEL TYPE	YAKICI TİPİ BURNER TYPE	KAPASİTE CAPACITY	M-L-H
TM-BSHT10	Gaz/Sıvı Gas/Liquid	Brülör Burner	1.000.000Kcal	M: 1800mm L: 4000mm H: 2200mm
TM-BSHT30	Gaz/Sıvı Gas/Liquid	Brülör Burner	3.000.000Kcal	M: 2400mm L: 4500mm H: 3500mm
TM-SSHT10	Katı Solid	Stoker	1.000.000Kcal	M: 1800mm L: 4000mm H: 2200mm
TM-SSHT30	Katı Solid	Stoker	3.000.000Kcal	M: 2400mm L: 4500mm H: 3500mm

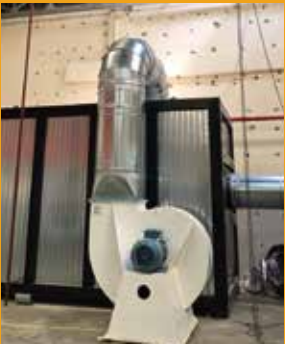

### TR

Termoblok, endüstriyel alanlarda sıcak hava üreten verimli bir ısıtıcıdır. Katı, sıvı veya gaz enerji kaynaklarıyla çalışır ve kullanım kolaylığı sağlar. Sıcak hava kontrolünü hassas bir şekilde yapabilmek için dijital kontrol sistemleriyle donatılmıştır. Ayrıca, yangın tehlikelerinin önlenmesi için güvenlik önlemleri içerir.

### EN

Thermoblock is an efficient heater that produces hot air in industrial areas. It works with solid, liquid or gas energy sources and provides ease of use. It is equipped with digital control systems to precisely control hot air flow and temperatures. It also includes safety measures to prevent fire hazards.

INDUSTRIAL BULGUR MACHINES

Since 1985  
**TÖPRAKÇILAR**  
MAKİNA SANAYİ VE TİC. LTD. ŞTİ



**HAVA FANI**

AIR FAN

# TEKNİK ÇİZİM VE ÖZELLİKLER

## TECHNICAL DRAWING AND FEATURES

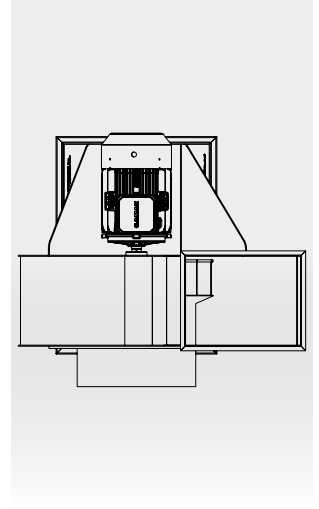
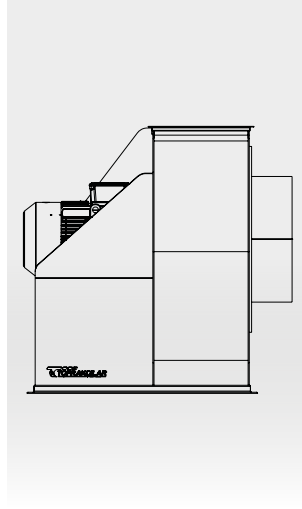
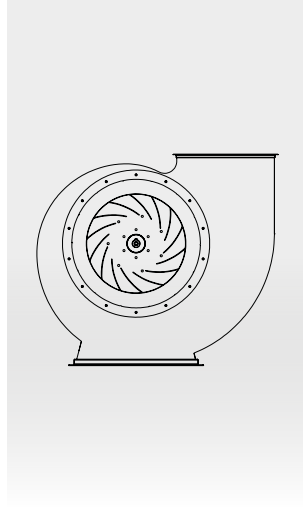
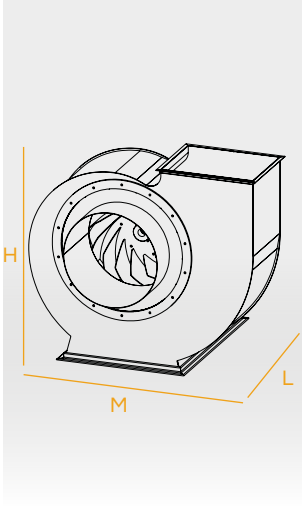

www.toprakcilarmakina.com

MODEL MODEL	MOTOR GÜCÜ MOTOR POWER	DEVİR REVOLUTION	KAPASİTE CAPACITY	M-L-H
<b>TM-HF20</b>	11kW	1500RPM	20000m <sup>3</sup> /h	<b>M: 1275<sup>mm</sup></b> <b>L: 980<sup>mm</sup></b> <b>H: 1150<sup>mm</sup></b>
<b>TM-HF30</b>	18,5kW	1500RPM	30000m <sup>3</sup> /h	<b>M: 1500<sup>mm</sup></b> <b>L: 1100<sup>mm</sup></b> <b>H: 1300<sup>mm</sup></b>
<b>TM-HF45</b>	37kW	1500RPM	45000m <sup>3</sup> /h	<b>M: 1850<sup>mm</sup></b> <b>L: 1350<sup>mm</sup></b> <b>H: 1700<sup>mm</sup></b>



### TR

Hava fanı, havayı hareket ettirerek soğutma, havalandırma ve hava dolaşımını sağlayan bir cihazdır. Bu fanlar, enerji tasarrufu sağlayacak şekilde tasarlanmış olup, düşük gürültü seviyeleriyle kullanıcı konforunu artırır. Farklı boyut ve güç seçenekleri sayesinde, çeşitli ihtiyaçlara uygun etkili çözümler sunar.

### EN

An air fan is a device that moves air to provide cooling, ventilation and air circulation. These fans are designed to save energy and increase user comfort with low noise levels. Thanks to different size and power options, effective solutions are offered to suit various needs.

Since 1985

**TÖPRAKÇILAR**

MAKİNA SANAYİ VE TİC. LTD. ŞTİ

INDUSTRIAL BULGUR MACHINES



**HAVA SİKLONU**

AIR CYCLONE

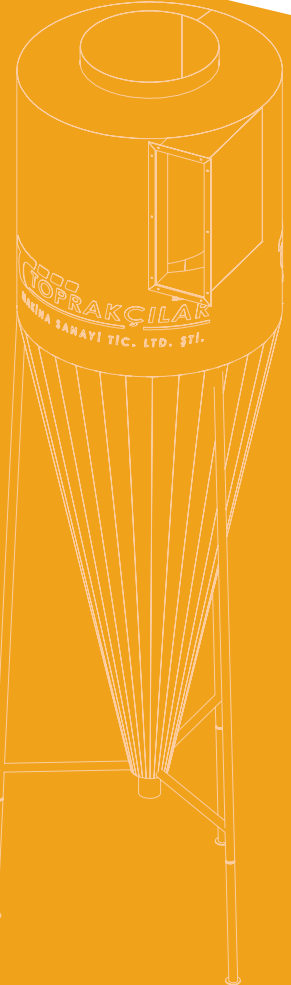



# TEKNİK ÇİZİM VE ÖZELLİKLER

## TECHNICAL DRAWING AND FEATURES

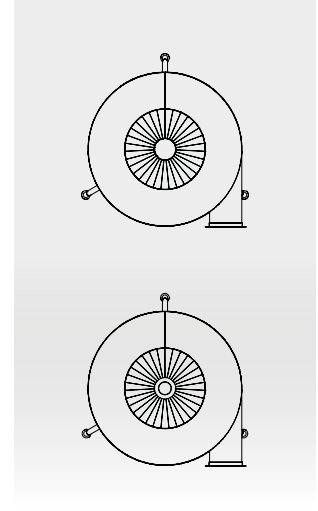
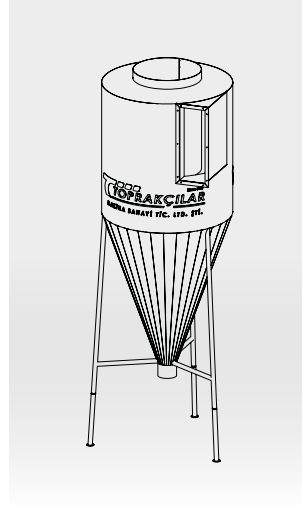
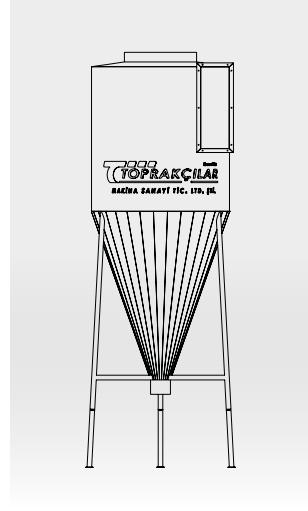
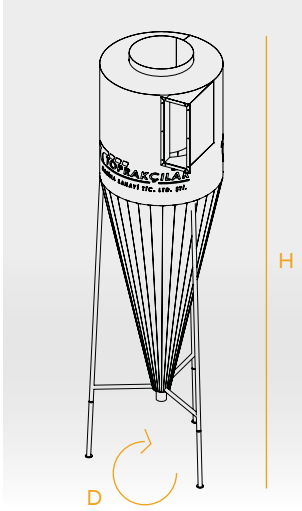

www.toprakcilarmakina.com

MODEL MODEL	GİRİŞ AĞZI PRODUCT INLET	ATIŞ AĞZI DISCHARGE OUTLET	ÜRÜN ÇIKIŞ AĞZI PRODUCT OUTLET	KAPASİTE CAPACITY	D-H
TM-HS30	850mmx300mm	ø750mm	ø200mm	30000m <sup>3</sup>	D: 1450mm H: 4400mm
TM-HS45	1100mmx400mm	ø850mm	ø200mm	45000m <sup>3</sup>	D: 1900mm H: 4400mm



### TR

Hava siklonu, hava akışındaki toz ve partikülleri ayırmak için kullanılan bir cihazdır. Siklonlar, santrifüj kuvveti ile ağır parçacıkları hava akışından ayırır ve toplar. Bu süreç, enerji tasarrufu sağlayarak işletme maliyetlerini düşürür. Farklı boyut ve kapasitelerde üretilen siklonlar, çeşitli endüstriyel ihtiyaçlara yönelik etkili çözümler sunar.

### EN

Air cyclone is a device used to separate dust and particles from the airflow. Cyclones separate and collect heavy particles from the airflow by centrifugal force. This process saves energy and reduces operating costs. Cyclones produced in different sizes and capacities offer effective solutions for various industrial needs.

INDUSTRIAL BULGUR MACHINES

Since 1985  
**TÖPRAKÇILAR**  
MAKİNA SANAYİ VE TİC. LTD. ŞTİ

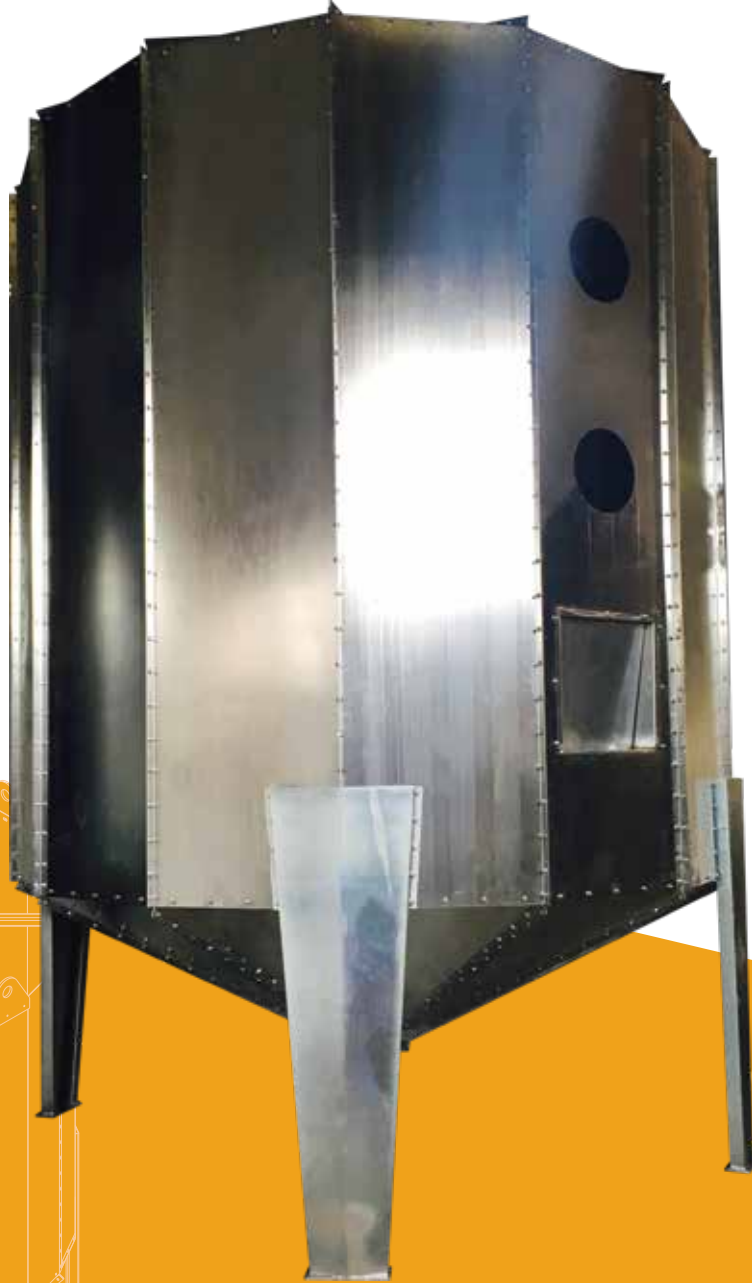

**STOK SİLOSU**

STORAGE SILO



# TEKNİK ÇİZİM VE ÖZELLİKLER

## TECHNICAL DRAWING AND FEATURES

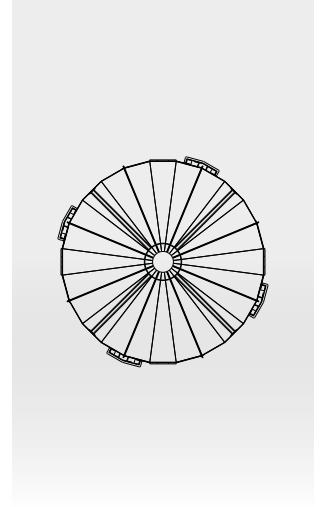
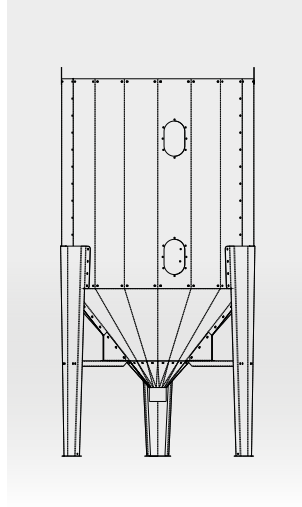
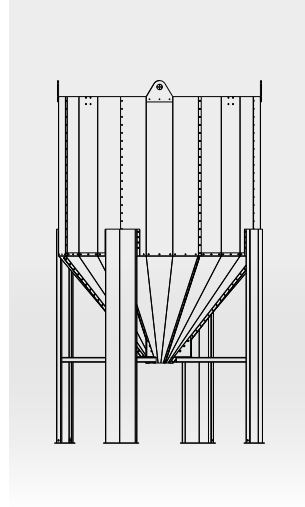
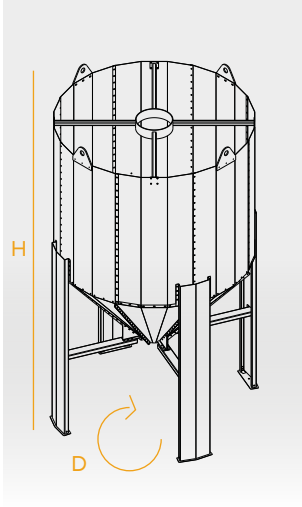

www.toprakcilarmakina.com

MODEL MODEL	GÖVDE YAPISI BODY STRUCTURE	ROTOFLOW	KAPASİTE CAPACITY	D-H
TM-SS3	Krom-CR-NI / Sac-Sheet metal / Galvaniz-Galvanized	Yok N/A	2,5m <sup>3</sup>	D: 1400 <sup>mm</sup> H: 3000 <sup>mm</sup>
TM-SS24	Krom-CR-NI / Sac-Sheet metal / Galvaniz-Galvanized	Yok N/A	24m <sup>3</sup>	D: 2200 <sup>mm</sup> H: 3600 <sup>mm</sup>
TM-SS24R	Krom-CR-NI / Sac-Sheet metal / Galvaniz-Galvanized	Var Available	24m <sup>3</sup>	D: 2200 <sup>mm</sup> H: 3600 <sup>mm</sup>



### TR

Hammadde depolama siloları, kompakt bir ayak izi ve sağlam bir yapı sunarak optimum bir çözüm sunar. Bu silolar, endüstri standartlarını karşılayacak şekilde tasarlanmıştır, malzemelerin güvenli bir şekilde muhafaza edilmesini sağlarken alan verimliliğini en üst düzeye çıkarır ve kolay erişim ve elleçlemeyi kolaylaştırır, böylece genel operasyonel üretkenliği artırır.

### EN

Raw material storage silos provide an optimal solution, offering a compact footprint and robust construction. These silos are engineered to meet industry standards, ensuring the secure containment of materials while maximizing space efficiency and facilitating easy access and handling, thus enhancing overall operational productivity.



# OTOMATİK TORBALAMA KANTARI

AUTOMATING BAGGING SCALE

# TEKNİK ÇİZİM VE ÖZELLİKLER

## TECHNICAL DRAWING AND FEATURES

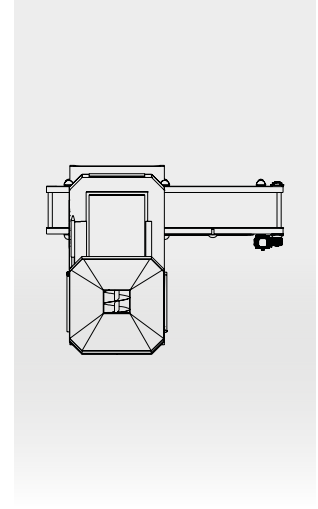
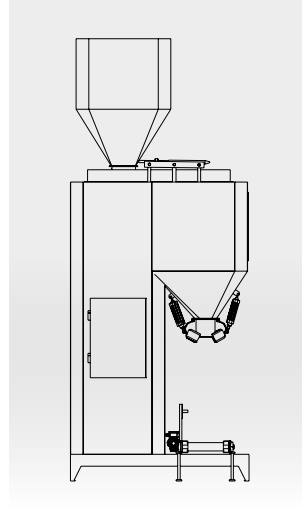
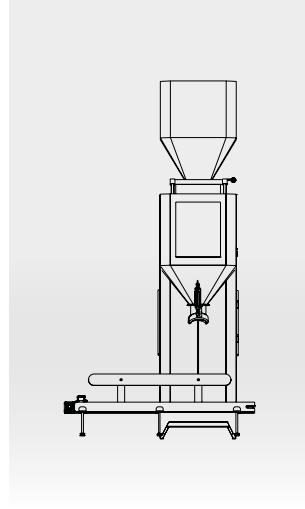
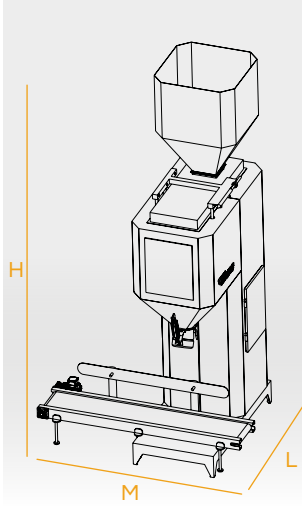

www.toprakcilmakina.com

MODEL MODEL	MOTOR GÜCÜ MOTOR POWER	TARTIM TİPİ WEIGHING TYPE	KEFE ADEDİ BUCKET NUMBER	KAPASİTE CAPACITY	M-L-H
TM-OTK10	1,5kW	Loadcell	Tek kefe Single-pan	5000-15000Kg/h	M: 2000 <sup>mm</sup> L: 1500 <sup>mm</sup> H: 3750 <sup>mm</sup>
TM-OTK20	2x1,5kW	Loadcell	Çift kefe Double-pan	15000-30000Kg/h	M: 3000 <sup>mm</sup> L: 1500 <sup>mm</sup> H: 3750 <sup>mm</sup>



### TR

Otomatik torbalama kantarı, toz, granül ve pelet gibi dökme malzemelerin hassas bir şekilde tartılıp torbalanmasını sağlar. Yüksek hassasiyetli tartım sistemi, ürünlerin doğru miktarda paketlenmesini garanti eder. Üretim verimliliğini artırırken insan hatalarını en aza indirir. Ayrıca, ürün kaybını önleyerek ambalajlama sürecini hızlandırır.

### EN

Automatic bagging scales for packaging of bags ensure accurate weighing and packaging of bulk materials such as powders, granules and pellets. The high-precision weighing system ensures packaging in the correct quantity. This minimizes human errors and at the same time increases production efficiency. In addition, this equipment speeds up the packaging process, preventing product loss.

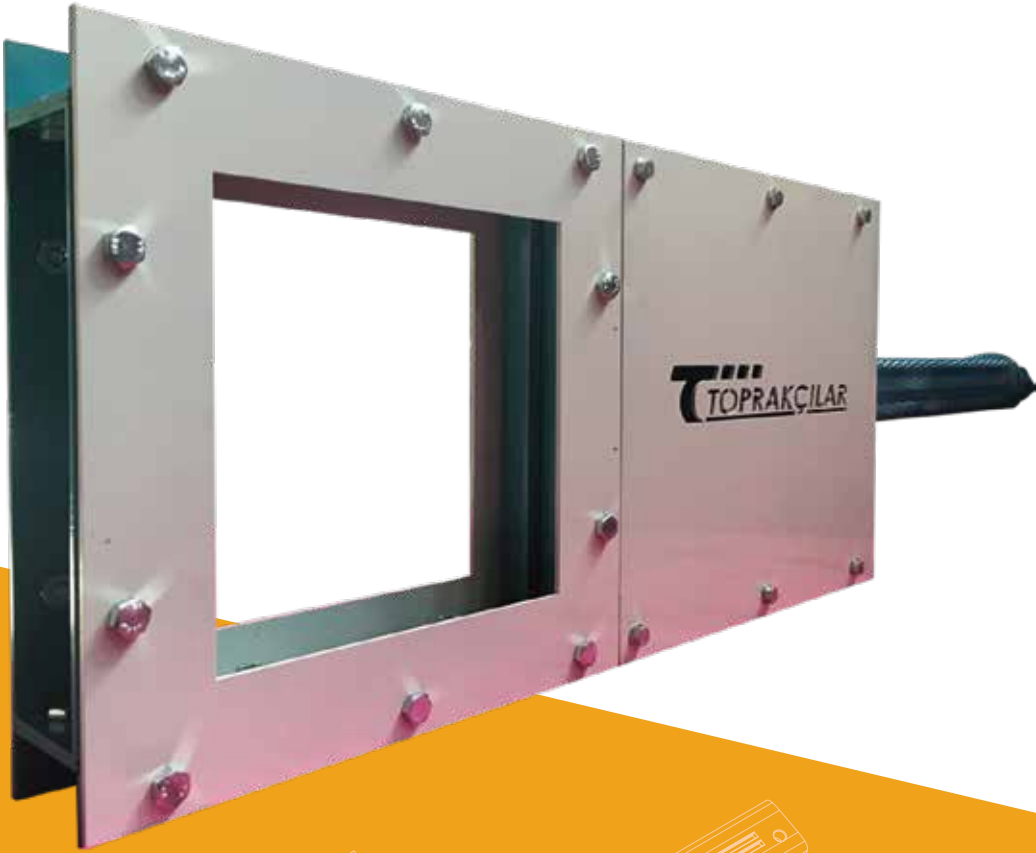

## PNOMATİK SÜRGÜ

PNEUMATIC SLIDE

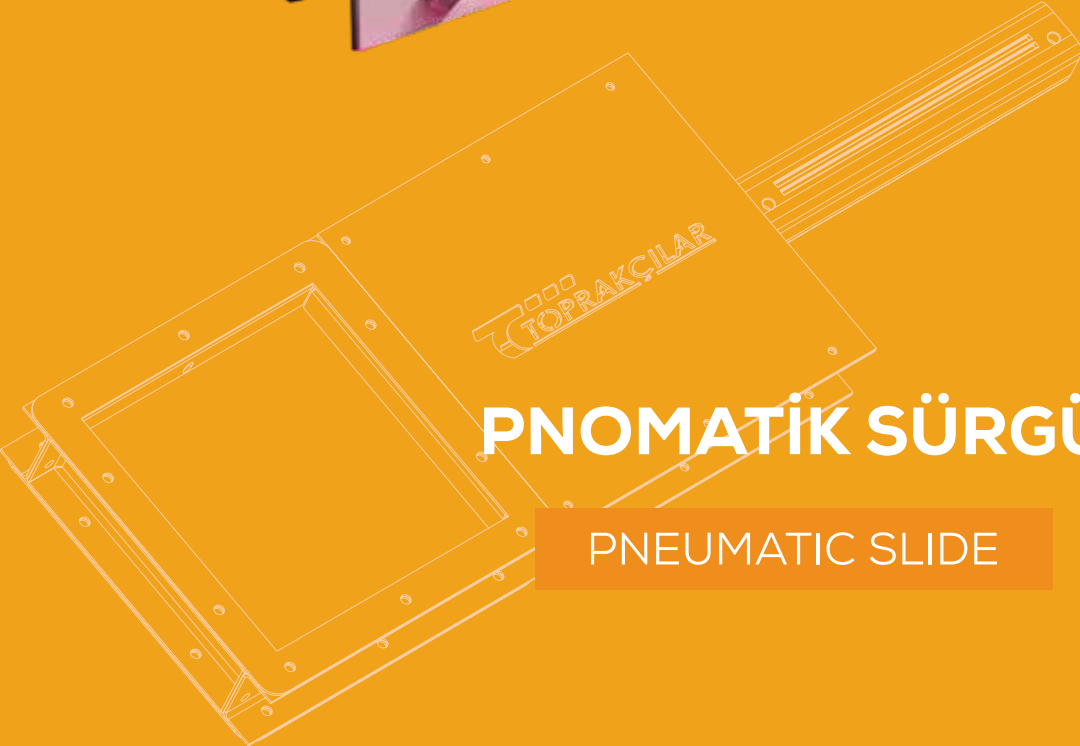

# TEKNİK ÇİZİM VE ÖZELLİKLER

## TECHNICAL DRAWING AND FEATURES

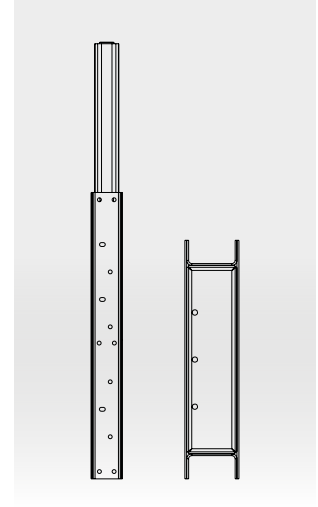
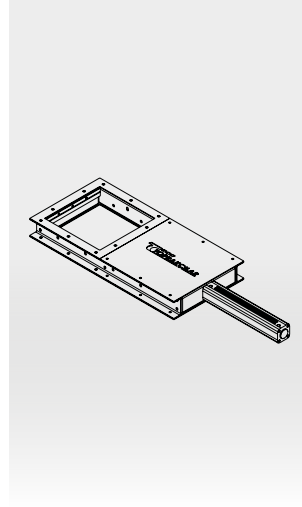
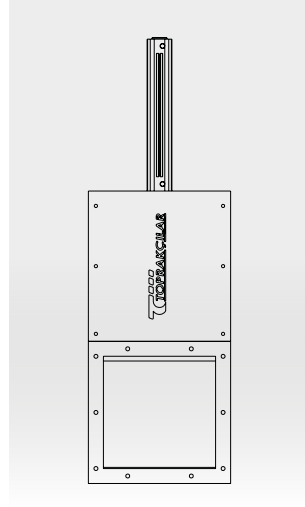
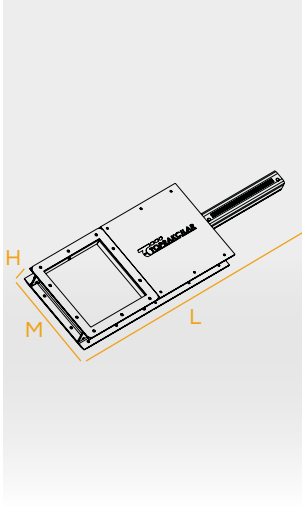

MODEL MODEL	PİSTON ÇAPI PISTON DIAMETER	PİSTON UZUNLUĞU PISTON LENGTH	KLEPE AĞZI VALVE MOUTH	M-L-H
TM-PS20	ø40 <sup>mm</sup>	200 <sup>mm</sup>	200 <sup>mm</sup> x 200 <sup>mm</sup>	M: 280 <sup>mm</sup> L: 750 <sup>mm</sup> H: 86 <sup>mm</sup>
TM-PS30	ø40 <sup>mm</sup>	300 <sup>mm</sup>	300 <sup>mm</sup> x 300 <sup>mm</sup>	M: 380 <sup>mm</sup> L: 1100 <sup>mm</sup> H: 86 <sup>mm</sup>
TM-PS35	ø50 <sup>mm</sup>	350 <sup>mm</sup>	350 <sup>mm</sup> x 350 <sup>mm</sup>	M: 430 <sup>mm</sup> L: 1200 <sup>mm</sup> H: 86 <sup>mm</sup>
TM-PS40	ø63 <sup>mm</sup>	400 <sup>mm</sup>	400 <sup>mm</sup> x 400 <sup>mm</sup>	M: 600 <sup>mm</sup> L: 1700 <sup>mm</sup> H: 100 <sup>mm</sup>
TM-PS50	ø63 <sup>mm</sup>	500 <sup>mm</sup>	500 <sup>mm</sup> x 500 <sup>mm</sup>	M: 600 <sup>mm</sup> L: 1830 <sup>mm</sup> H: 100 <sup>mm</sup>

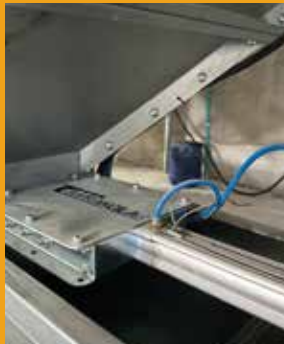

### TR

Pnömatik sürgü, malzeme akışını kontrol etmek için kullanılan bir ekipmandır. Sıkıştırılmış hava ile çalışan bu sistem, kayan bir kapıyı açıp kapatarak malzeme boşaltımını hassas bir şekilde düzenler. Tıkanma riskini azaltan ve kesintisiz çalışmayı sağlayan pnömatik sürgüler, malzeme taşıma sistemlerinde güvenilir bir performans sunar ve verimlilik ile üretkenliği artırmaya yardımcı olur.

### EN

A pneumatic slide is a piece of equipment used to control material flow. This system, which works with compressed air, precisely regulates material discharge by opening and closing a sliding door. Pneumatic slides, which reduce the risk of blockages and ensure uninterrupted operation, provide reliable performance in material handling systems and help increase efficiency and productivity.

INDUSTRIAL BULGUR MACHINES

Since 1985  
**TOPRAKÇILAR**  
MAKİNA SANAYİ VE TİC. LTD. ŞTİ



**ELEVATÖR**

BUCKET ELEVATOR



# TEKNİK ÇİZİM VE ÖZELLİKLER

## TECHNICAL DRAWING AND FEATURES

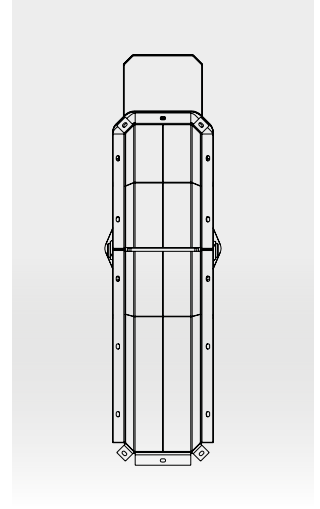
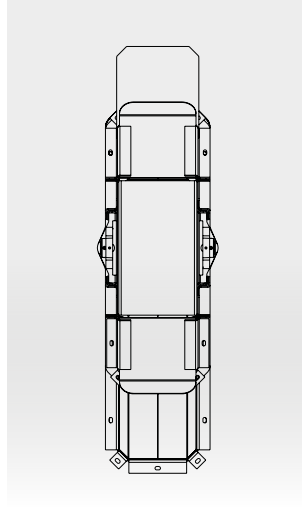
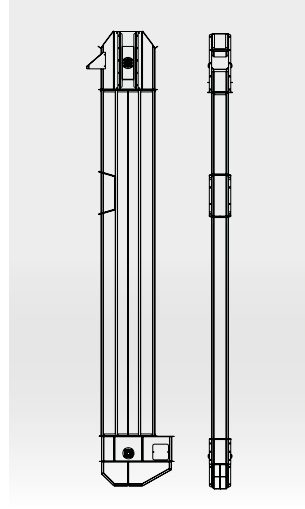
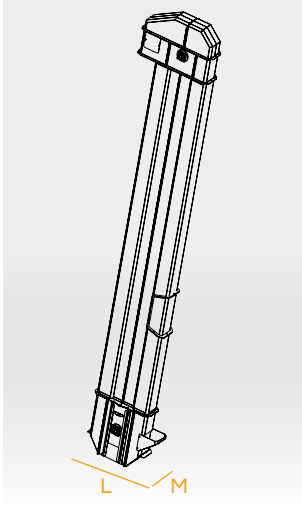

www.toprakcilarmakina.com

MODEL MODEL	MOTOR GÜCÜ MOTOR POWER	KOVA ÖLÇÜSÜ BUCKET SIZE	KAYIŞ ÖLÇÜSÜ BELT SIZE	M-L
TM-E10	2,2kW	140 <sup>mm</sup>	160 <sup>mm</sup>	M: 260 <sup>mm</sup> L: 850 <sup>mm</sup>
TM-E20	3kW	240 <sup>mm</sup>	260 <sup>mm</sup>	M: 360 <sup>mm</sup> L: 960 <sup>mm</sup>



### TR

Kovalı elevatör, ürünlerin dikey olarak bir yerden başka bir yere taşınmasını sağlayan bir makinedir. Bu taşıma işlemi, kayış üzerine monte edilen özel kovaların her seferde belirli bir miktarda ürün almasıyla gerçekleştirilir. Kullanım alanına ve taşınacak ürünün özelliklerine göre uygun ölçü ve kova seçimi yapılır. Elevatörün taşıma kapasitesi ise ürünün türüne bağlı olarak değişiklik gösterir.

### EN

Bucket elevator is a machine that allows products to be transported vertically from one place to another. This transportation process is carried out by special buckets mounted on belts that take a certain amount of product each time. The appropriate size and bucket selection is made according to the area of use and the characteristics of the product to be transported. The carrying capacity of the elevator varies depending on the type of product.



## BORU HELEZON

TUBULAR SCREW CONVEYORS

# TEKNİK ÇİZİM VE ÖZELLİKLER

## TECHNICAL DRAWING AND FEATURES

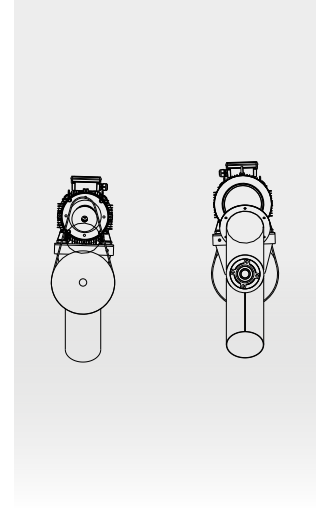
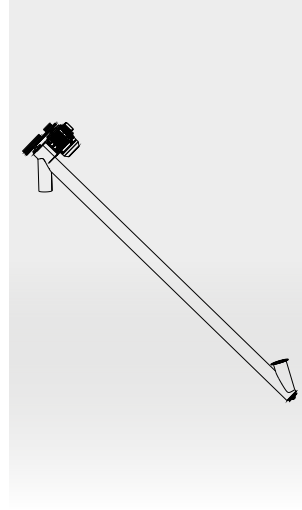
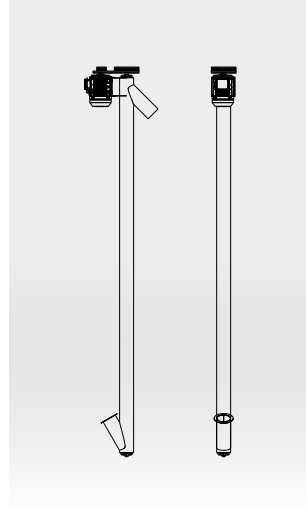
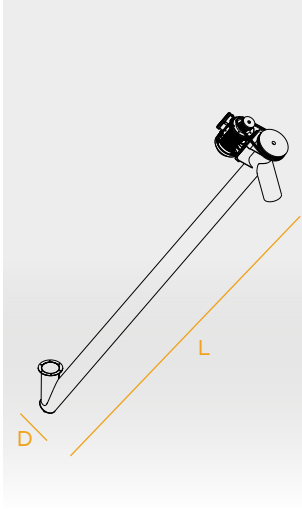

www.toprakcilarmakina.com

MODEL MODEL	MOTOR GÜCÜ MOTOR POWER	HELEZON ÇAPI SCREW DIAMETER	GÖVDE YAPISI BODY STRUCTURE	D-L
TM-BH10	2,2kW	ø168 <sup>mm</sup>	Metal / Krom Metal / CR-NI	D: 250 <sup>mm</sup> L: 6000 <sup>mm</sup>
TM-BH15	3kW	ø219 <sup>mm</sup>	Metal / Krom Metal / CR-NI	D: 320 <sup>mm</sup> L: 6000 <sup>mm</sup>
TM-BH20	4kW	ø273 <sup>mm</sup>	Metal / Krom Metal / CR-NI	D: 400 <sup>mm</sup> L: 6000 <sup>mm</sup>



### TR

Vidalı konveyör, sarmal burğu şeklinde tasarlanmış borulu taşıma sistemleridir ve ürünleri yatay ya da dikey olarak taşımak için kullanılır. Helezonlar, belirli bir adım hesabına göre üretildiği için bu adı almıştır. Ürünün türü, boyutu, üretim tesisinin kapasitesi ve nem oranına bağlı olarak farklı boyut ve tasarımlarda üretilebilir.

### EN

Tubular Screw Conveyors are tubular conveying systems designed in the form of a spiral screw and are used to transport products horizontally or vertically. The screws are named because they are produced according to a certain step calculation. They can be produced in different sizes and designs depending on the type of product, size, capacity of the production facility and humidity rate.

INDUSTRIAL BULGUR MACHINES

Since 1985  
**TÖPRAKÇILAR**  
MAKİNA SANAYİ VE TİC. LTD. ŞTİ



**U TİPİ HELEZON**

U-TYPE SCREW CONVEYOR

# TEKNİK ÇİZİM VE ÖZELLİKLER

## TECHNICAL DRAWING AND FEATURES

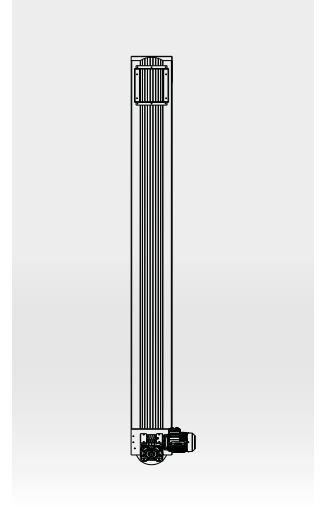
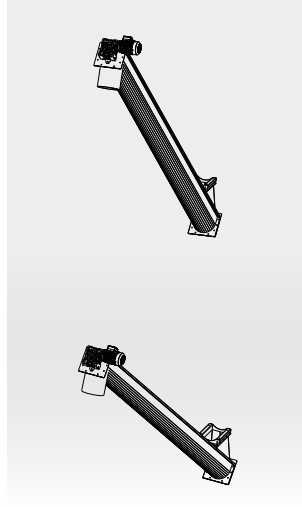
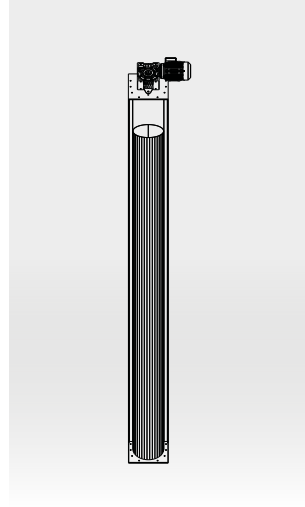
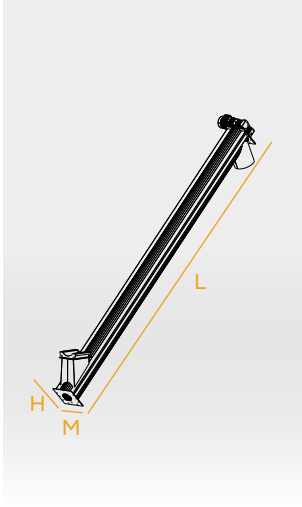

www.toprakcilarmakina.com

MODEL MODEL	MOTOR GÜCÜ MOTOR POWER	HELEZON ÇAPI SCREW DIAMETER	GÖVDE YAPISI BODY STRUCTURE	M-L-H
TM-UH15	2,2kW	ø250mm	Metal / Krom Metal / CR-NI	M: 330mm L: 530mm H: 380mm
TM-UH25	3kW	ø300mm	Metal / Krom Metal / CR-NI	M: 380mm L: 580mm H: 380mm
TM-UH35	4kW	ø350mm	Metal / Krom Metal / CR-NI	M: 430mm L: 630mm H: 380mm
TM-UH45	5,5kW	ø450mm	Metal / Krom Metal / CR-NI	M: 550mm L: 750mm H: 380mm



### TR

U tipi helezon, malzemelerin taşınması ve işlenmesi için kullanılan bir ekipmandır. Kapalı bir boru içinde dönen vida mekanizmasıyla toz, granül ve pelet gibi dökme malzemeleri yatay veya hafif eğimli şekilde taşır. Hijyenik ve sızdırmaz yapısıyla özellikle gıda ve kimya endüstrilerinde tercih edilir. Taşıma sırasında toz oluşumunu en aza indirerek çevre temizliğine katkı sağlar.

### EN

U-Type Screw Conveyor is the conveyor type used for the transportation and processing of materials. It carries bulk materials such as powder, granules and pellets horizontally or in a slightly inclined position with a screw mechanism rotating in a closed pipe. Its hygienic and leak-proof structure is especially preferred in the food and chemical industries. It contributes to environmental cleanliness by minimizing dust formation during transportation.

INDUSTRIAL BULGUR MACHINES

Since 1985  
**TÖPRAKÇILAR**  
MAKİNA SANAYİ VE TİC. LTD. ŞTİ



**YÜKLEME HELEZONU**

TRANSPORT SPIRAL CONVEYOR

# TEKNİK ÇİZİM VE ÖZELLİKLER

## TECHNICAL DRAWING AND FEATURES

www.toprakcilarmakina.com

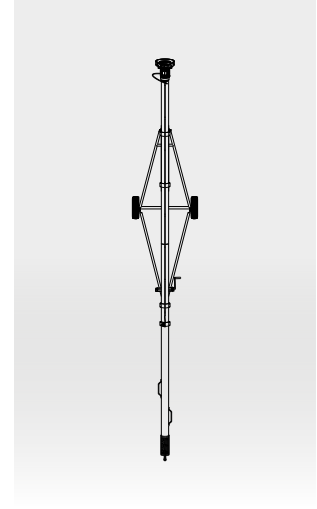
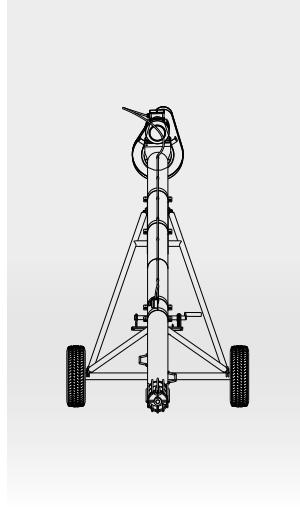
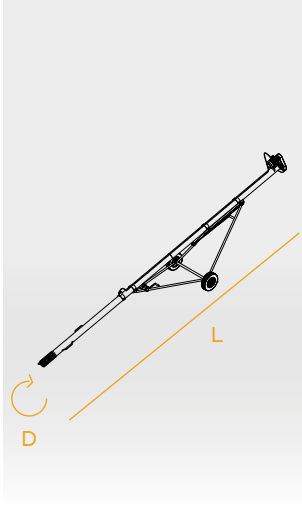

MODEL MODEL	MOTOR GÜCÜ MOTOR POWER	HELEZON YAPRAK ÇAPI SPIRAL LEAF DIAMETER	MİNİMUM MAXİMUM YÜKSEKLİK MINIMUM MAXIMUM HEIGHT	AKS UZUNLUK AXIS LENGTH	D-L
TM-NH4	4kW	ø140mm	min: 1600 <sup>mm</sup> max: 3000 <sup>mm</sup>	2200 <sup>mm</sup>	D: 168 <sup>mm</sup> L: 8000 <sup>mm</sup>
TM-NH55	5,5kW	ø140mm	min: 2100 <sup>mm</sup> max: 3500 <sup>mm</sup>	2200 <sup>mm</sup>	D: 168 <sup>mm</sup> L: 10000 <sup>mm</sup>
TM-NH75	7,5kW	ø200mm	min: 2500 <sup>mm</sup> max: 4500 <sup>mm</sup>	2200 <sup>mm</sup>	D: 168 <sup>mm</sup> L: 12000 <sup>mm</sup>



### TR

Nakliye helezonları, taneli ürün ve benzeri malzemelerin doldurma ve boşaltma işlemleri için kullanılır. Kayış kasnak destekli çift helezon sistemi sayesinde, farklı uzunluklarda ve kapasitede üretilebilir. Bu sistem, statik olarak uygun bir şekilde çalışır. Böylece, malzeme taşımada yüksek verimlilik sağlar.

### EN

Transport Spiral Conveyors by Toprakçılar Makina are designed for efficient filling and unloading operations of granular products and similar materials. Featuring a double spiral system supported by a belt and pulley mechanism, these transport spirals can be customized in various lengths and capacities to suit specific operational needs. The system is engineered for static stability, ensuring smooth and reliable material handling. This design maximizes efficiency in material transportation, offering a high-performance solution for bulk handling applications in the food processing and agricultural industries.



## YÜKLEME BANDI

LOADING CONVEYOR

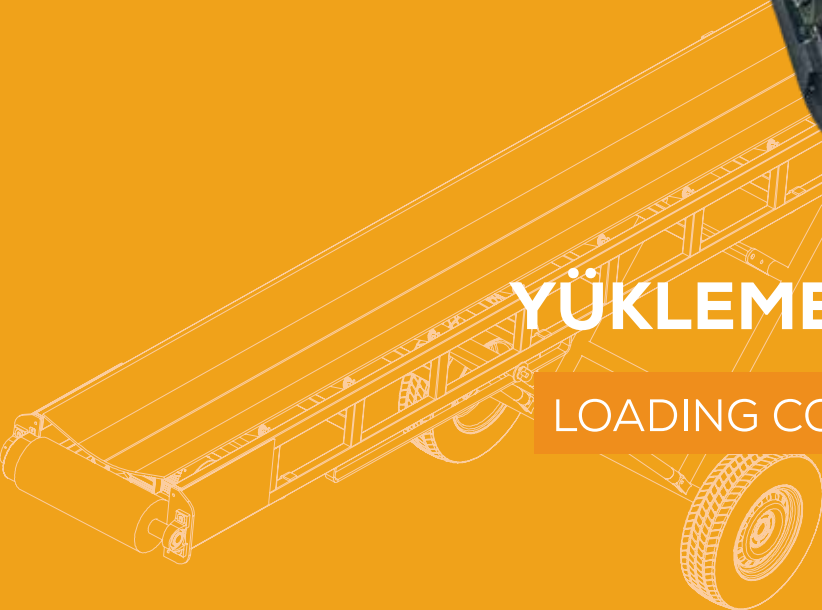



# TEKNİK ÇİZİM VE ÖZELLİKLER

## TECHNICAL DRAWING AND FEATURES

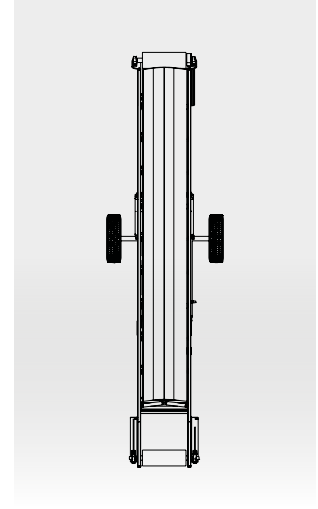
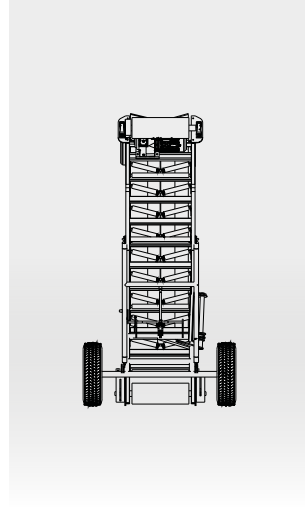
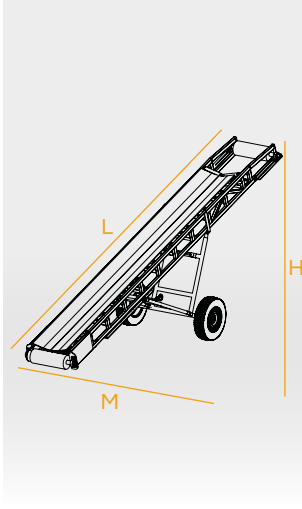

www.toprakcilarmakina.com

MODEL MODEL	MOTOR GÜCÜ MOTOR POWER	DEVİR REVOLUTION	BANT GENİŞLİĞİ BANDWIDTH	M-L-H
TM-YB8	2,2kW	50RPM	600 <sup>mm</sup>	M: 1580 <sup>mm</sup> L: 4500 <sup>mm</sup> H: 8000 <sup>mm</sup>
TM-YB10	3kW	50RPM	600 <sup>mm</sup>	M: 1580 <sup>mm</sup> L: 4500 <sup>mm</sup> H: 10000 <sup>mm</sup>
TM-YB12	3kW	50RPM	600 <sup>mm</sup>	M: 1580 <sup>mm</sup> L: 4500 <sup>mm</sup> H: 12000 <sup>mm</sup>



### TR

Çuvallanmış ürünlerin istiflenmesi veya araçlara yüklenmesi amacıyla kullanılan konveyör bant, redüktör yardımıyla hareket eder. Bu bant, gıda tüzüğüne uygun olarak istenilen genişlik ve uzunlukta üretilebilir. Nakliye bandının kapasitesi ise taşınacak ürünün özelliklerine bağlı olarak değişir.

### EN

Loading Conveyor used for stacking or loading bagged products onto vehicle moves with the help of a reducer. This conveyor can be produced in the desired width and length in accordance with food regulations. The capacity of the transport belt varies depending on the product's characteristics to be transported.



# OTOMASYON VE KONTROL PANOSU

AUTOMATION AND CONTROL PANEL

# TEKNİK ÇİZİM VE ÖZELLİKLER

## TECHNICAL DRAWING AND FEATURES

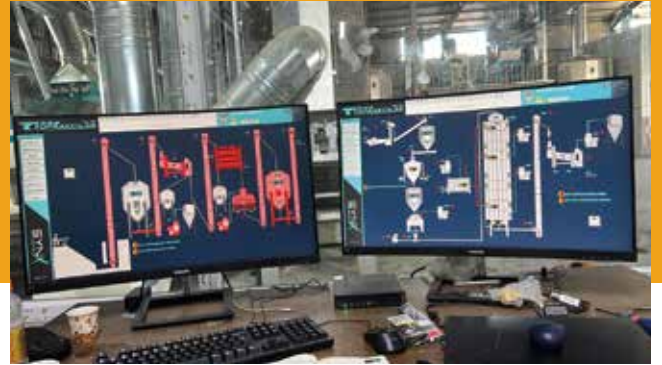

### TR

Otomasyon ve kontrol panosu, üretim süreçlerini izlemek ve yönetmek amacıyla kullanılan bir sistemdir. Bu panolar, makinelerin ve ekipmanların otomatik olarak çalışmasını sağlayarak insan müdahalesini en aza indirir ve üretim verimliliğini artırır. Sensörler, motorlar ve diğer elektronik bileşenlerle entegre olan bu panolar, süreçlerin anlık olarak izlenmesini ve gerektiğinde hızlı müdahale edilmesini sağlar. Ayrıca enerji tüketimini optimize ederek maliyet tasarrufu sağlar ve üretim hattındaki hataları azaltır. Modern otomasyon panoları, üretim sürecini daha güvenli, tutarlı ve verimli hale getirir.

### EN

Automation and control panels are systems used to monitor and manage production processes. These panels minimize human intervention and increase production efficiency by ensuring that machines and equipment operate automatically. Integrated with sensors, motors and other electronic components, these panels allow instant monitoring of processes and rapid intervention when necessary. They also optimize energy consumption, saving costs and reducing errors in the production line. Modern automation panels make the production process safer, more consistent and more efficient.





*Değirmencilik sektöründe  
profesyonel çözümler*

*Professional solutions in  
milling industry*



INSTAGRAM



YOUTUBE



WEBSITE



LINKEDIN

[www.toprakcilarmakina.com](http://www.toprakcilarmakina.com)    [admin@toprakcilarmakina.com](mailto:admin@toprakcilarmakina.com)

ORGANİZE SANAYİ BÖLGESİ 13. SOKAK NO:3

MERKEZ / KARAMAN / TÜRKİYE

0 (338) 224 12 63 - 64